

Preisliste Metall
Price List Metal



Gültig ab 01.01.2011
Effective from 01.01.2011



Power Transmission

INHALTSVERZEICHNIS

	Seite
optibelt TB Taper-Buchsen	3
Ausführungen der optibelt K5 Keilrillenscheiben – Auswuchten, Aufschläge für Fertigbohrungen	4
optibelt K5 Keilrillenscheiben für Taper-Buchsen – Rillen nach DIN 2211	5-12
optibelt K5 Keilrillenscheiben für zylindrische Bohrung – Rillen nach DIN 2211	13-18
optibelt RE Regelscheiben	19-21
optibelt RBS Keilrippenscheiben für Taper-Buchsen	22-26
optibelt RBS Keilrippenscheiben für zylindrische Bohrung	26
optibelt F5 Flachriemenscheiben für Taper-Buchsen	27
optibelt M5 Motorspannschienen	28
optibelt M5 Motorspannschlitten	29
optibelt ZRS Standard-Zahnscheiben für zylindrische Bohrung	30-35
optibelt ZRS Standard-Zahnscheiben für Taper-Buchsen	36-41
optibelt ZRS HTD®-Zahnscheiben für zylindrische Bohrung.....	42-49
optibelt ZRS HTD®-Zahnscheiben für Taper-Buchsen	50-55
optibelt ZRS Metrische Zahnscheiben für zylindrische Bohrung, T-Type	56-60
optibelt ZRS Metrische Zahnscheiben für zylindrische Bohrung, AT-Type...	61-64
optibelt ZRW Standard-Zahnwellen	65-66
optibelt ZRW Metrische Zahnwellen	67-68
optibelt CP Spannplatten	69-70
optibelt TN Tapernaben	71
optibelt TN Zwischenhülsen	72
optibelt CE Spannelemente	73-88

CONTENTS

	Page
optibelt TB Taper Bushings	3
Types of optibelt K5 V-Grooved Pulleys – Balancing, Surchxarges for Finished Bores	4
optibelt K5 V-Grooved Pulleys for Taper Bushings – Grooves to ISO/BS/DIN	5-12
optibelt K5 V-Grooved Pulleys for Plain Boring – Grooves to ISO/BS/DIN	13-18
optibelt RE Variable Speed Pulleys	19-21
optibelt RBS Ribbed Belt Pulleys for Taper Bushings	22-26
optibelt RBS Ribbed Belt Pulleys for Plain Boring	26
optibelt F5 Flat Belt Pulleys for Taper Bushings	27
optibelt M5 Motor Slide Rails.....	28
optibelt M5 Motor Slide Bases.....	29
optibelt ZRS Timing Belt Pulleys for Plain Boring	30-35
optibelt ZRS Timing Belt Pulleys for Taper Bushings	36-41
optibelt ZRS HTD® Pulleys for Plain Boring	42-49
optibelt ZRS HTD® Pulleys for Taper Bushings	50-55
optibelt ZRS Metric Timing Belt Pulleys for Plain Boring, T Profiles.....	56-60
optibelt ZRS Metric Timing Belt Pulleys for Plain Boring, AT Profiles	61-64
optibelt ZRW Timing Bars for Standard Timing Belts	65-66
optibelt ZRW Timing Bars for Metric Timing Belts	67-68
optibelt CP Clamping Plates	69-70
optibelt TN Taper Hubs	71
optibelt TN Adapters	72
optibelt CE Clamping Bushings	73-88

Die Preise dieser Liste stellen keine Preisempfehlung für den Weiterverkauf dar. **Versandkosten zu Lasten des Empfängers.** Bezüglich der Haftung und Lieferung verweisen wir auf unsere allgemeinen Geschäftsbedingungen. Mit Erscheinen dieser Liste verlieren alle früheren Preislisten ihre Gültigkeit, dies gilt auch für vorhergehende Auflagen. Änderungen aufgrund technischer Neuerungen sowie Irrtum vorbehalten. Nachdruck verboten. Zuwiderhandlungen werden urheberrechtlich verfolgt.

The prices in this list are not for resale use. Freight charges are the responsibility of the customer. Refer to our "General Conditions of Sale" for matters concerning liability and delivery. With the introduction of this list all other price lists are superceded. Alterations due to error or to technical improvements are excepted. Reprinting or photocopying forbidden. Violations of copyright will be prosecuted.

Taper-Buchsen mit metrischer Bohrung, Nut nach DIN 6885 Teil 1 Taper bushings with metric bores. Keyways to DIN 6885 part 1																
	Taper-Buchse Taper bushing															
	Material: EN-GJL 200 – DIN EN 1561															
	1008	1108	1210	1215	1310	1610	1615	2012	2517	3020	3030	3525	3535	4040	4545	5050
Bohrungs- durch- messer Bore diameter d ₂ (mm)	10	10	11	11	14	14	14	14	16	25	35	35	35	40	55	70
	11	11	12	12	16	16	16	16	18	28	38	38	38	42	60	75
	12	12	14	14	18	18	18	18	19	30	40	40	40	45	65	80
	14	14	16	16	19	19	19	19	20	32	42	42	42	48	70	85
	15	15	18	18	20	20	20	20	22	35	45	45	45	50	75	90
	16	16	19	19	22	22	22	22	24	38	48	48	48	55	80	95
	18	18	20	20	24	24	24	24	25	40	50	50	50	60	85	100
	19	19	22	22	25	25	25	25	28	42	55	55	55	65	90	105
	20	20	24	24	28	28	28	28	30	45	60	60	60	70	95	110
	22	22	25	25	30	30	30	30	32	48	65	65	65	75	100	115
	24▲	24	28	28	32	32	32	32	35	50	70	70	70	80	105	120
	25▲	25	30	30	35	35	35	35	38	55	75	75	75	85	110	125
			28▲	32	32		38	38	38	40	60		80	80	90	
						40	40	40	42	65		85	85	95		
						42▲	42▲	42	45	70		90	90	100		
								45	48							
								48	50							
								50	55							
									60							
Innensechskant- schrauben Hexagon socket screws (Zoll inch)	1/4 x 1/2	1/4 x 1/2	3/8 x 5/8	3/8 x 5/8	3/8 x 5/8	3/8 x 5/8	3/8 x 5/8	7/16 x 7/8	1/2 x 1	5/8 x 1 1/4	5/8 x 1 1/4	1/2 x 1 1/2	1/2 x 1 1/2	5/8 x 1 3/4	3/4 x 2	7/8 x 2 1/4
Anzug Tighten- ing torque (Nm)	5,7	5,7	20	20	20	20	20	31	49	92	92	115	115	172	195	275
Buchsenlänge Bushing length (mm)	22,3	22,3	25,4	38,1	25,4	25,4	38,1	31,8	44,5	50,8	76,2	63,5	88,9	101,6	114,3	127,0
Gewicht bei Weight at d _{2 min} (≈ kg)	0,12	0,16	0,28	0,39	0,32	0,41	0,60	0,75	1,06	2,50	3,75	3,90	5,13	7,68	12,70	15,17
Fr. Stück each	12,48	12,96	18,40	20,16	20,48	20,80	23,04	24,64	37,60	50,24	66,08	102,56	127,04	178,56	227,20	347,20

Ab 3525: Zylinderkopfschraube mit Innensechskant From 3525: Hexagon head screw ▲ Diese Bohrung ist mit Flachnut ausgeführt. These bores have shallow keyways.

Flachnute für Taper-Buchsen Shallow keyways for taper bushings

Bohrungsdurchm. Bore diameter d ₂ (mm)	Nutbreite Keyway width b (mm)	Nuttiefe Keyway depth t ₂ (mm)	Bohrungsdurchm. Bore diameter d ₂ (mm)	Nutbreite Keyway width b (mm)	Nuttiefe Keyway depth t ₂ (mm)
24	8	2,0	28	8	2,0
25	8	1,3	42	12	2,2

Taper-Buchsen mit Zoll-Bohrung, Nut nach Britischem Standard BS 46 Teil 1 Taper bushings with inch bores. Keyways to BS 46 part 1																	
	Taper-Buchse Taper bushing																
	Material: EN-GJL 200 – DIN EN 1561																
	1008	1108	1210	1215	1310	1610	1615	2012	2517	3020	3030	3525	3535	4040	4545	5050	
Bohrungs- durch- messer Bore diameter d ₂ (Zoll inch)	3/8*	3/8*	1/2	5/8*	1/2*	1/2	1/2	5/8*	3/4	1 1/4	1 1/4	1 1/2*	1 1/2	1 3/4*	2 1/4*	3*	
	1/2	1/2	5/8	3/4	5/8*	5/8	5/8	3/4	7/8	1 3/8	1 3/8	1 5/8*	1 5/8	1 7/8*	2 3/8*	3 1/4*	
	5/8	5/8	3/4	7/8	3/4*	3/4	3/4	3/4	1	1 1/2	1 1/2	1 3/4*	1 3/4	2*	2 1/2*	3 1/2*	
	3/4	3/4	7/8	1	7/8*	7/8	7/8	7/8	1	1 1/8	1 5/8	1 5/8	1 7/8*	1 7/8	2 1/8*	2 3/4*	3 3/4*
	7/8*	7/8	1	1 1/8	1*	1	1	1	1 1/8	1 1/4	1 3/4*	1 3/4*	2*	2	2 1/4*	2 7/8*	4*
	1▲	1	1 1/8	1 1/4	1 1/8	1 1/8	1 1/8	1 1/8	1 1/4	1 3/8	1 7/8	1 7/8	2 1/8*	2 1/8	2 3/8*	3*	4 1/4*
		1 1/8▲*	1 1/4		1 1/4	1 1/4	1 1/4	1 1/4	1 3/8	1 1/2	2	2	2 1/4*	2 1/4	2 1/2*	3 1/4*	4 1/2*
					1 3/8	1 3/8	1 3/8	1 3/8	1 1/2	1 5/8	2 1/8*	2 1/8*	2 3/8*	2 3/8	2 5/8*	3 3/8*	4 3/4*
					1 1/2	1 1/2	1 1/2	1 1/2	1 5/8	1 3/4	2 1/4	2 1/4	2 1/2*	2 1/2	2 3/4*	3 1/2*	5▲*
					1 5/8	1 5/8	1 5/8	1 5/8	1 3/4	1 7/8	2 3/8	2 3/8	2 5/8*	2 5/8	2 7/8*	3 3/4*	
									1 7/8	2	2 1/2	2 1/2	2 3/4*	2 3/4	3*	4*	
									2	2 1/8	2 5/8	2 5/8	2 7/8*	2 7/8	3 1/8*	4 1/4▲*	
										2 1/4	2 3/4	2 3/4	3*	3	3 1/4*	4 1/2▲*	
									2 3/8	2 7/8	2 7/8	3 1/8*	3 1/8	3 3/8*			
									2 1/2	3	3	3 1/4*	3 1/4	3 1/2*			
												3 3/8*	3 3/8	3 3/4▲*			
												3 1/2▲*	3 1/2▲	4▲*			
Innensechskant- schrauben Hexagon socket screws (Zoll inch)	1/4 x 1/2	1/4 x 1/2	3/8 x 5/8	3/8 x 5/8	3/8 x 5/8	3/8 x 5/8	3/8 x 5/8	7/16 x 7/8	1/2 x 1	5/8 x 1 1/4	5/8 x 1 1/4	1/2 x 1 1/2	1/2 x 1 1/2	5/8 x 1 3/4	3/4 x 2	7/8 x 2 1/4	
Anzug Tighten- ing torque (Nm)	5,7	5,7	20	20	20	20	20	31	49	92	92	115	115	172	195	275	
Buchsenlänge Bushing length (mm)	22,3	22,3	25,4	38,1	25,4	25,4	38,1	31,8	44,5	50,8	76,2	63,5	88,9	101,6	114,3	127,0	
Gewicht bei Weight at d _{2 min} (≈ kg)	0,12	0,16	0,28	0,39	0,32	0,41	0,60	0,75	1,06	2,50	3,75	3,90	5,13	7,68	12,70	15,17	
Fr. Stück each	12,48	12,96	18,40	20,16	20,48	20,80	23,04	24,64	37,60	50,24	66,08	102,56	127,04	178,56	227,20	347,20	

Ab 3525: Zylinderkopfschraube mit Innensechskant From 3525: Hexagon head screw

* Keine Lagerware Non stock items ▲ Diese Bohrung ist mit Flachnut ausgeführt. These bores have shallow keyways.

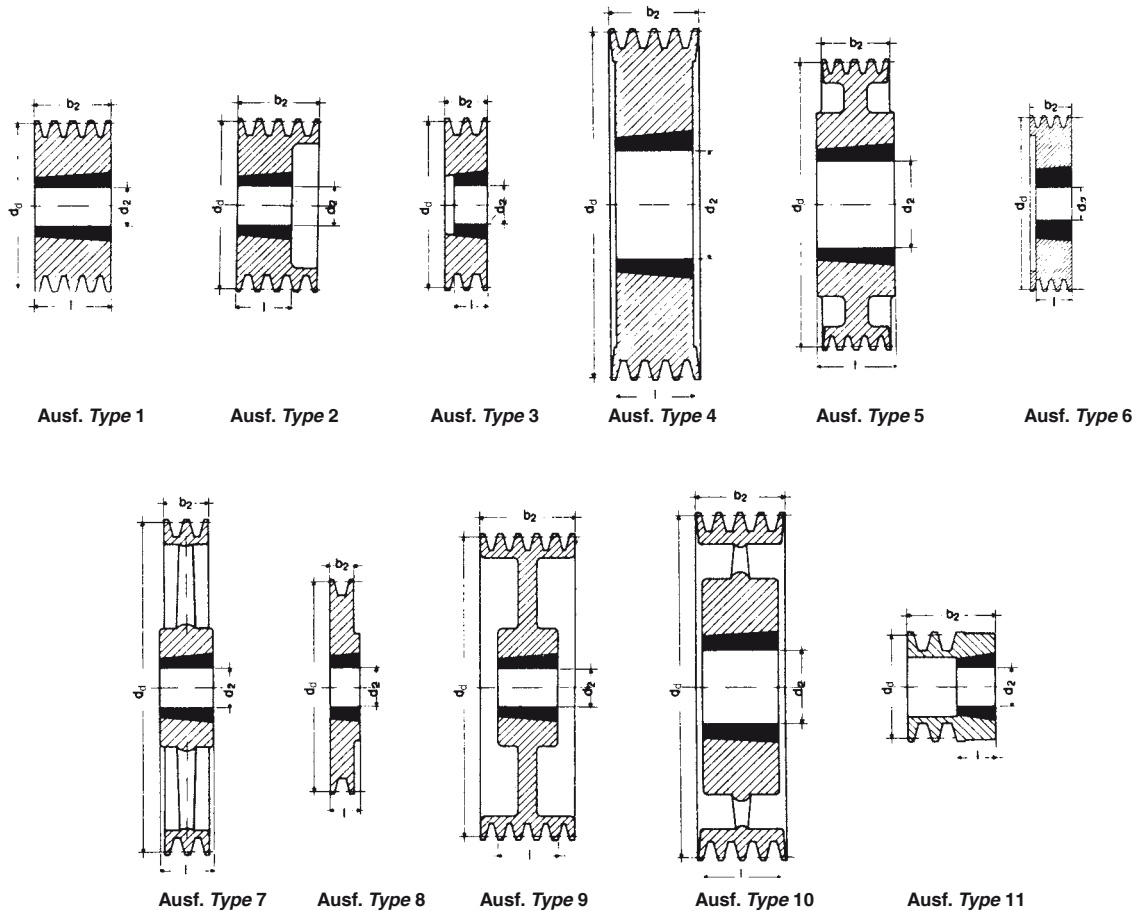

Fertigungstechnische Änderungen der Ausführungen vorbehalten.
 We reserve the right to make technical changes.

Auswuchten

Die Listenpreise gelten für in einer Ebene nach DIN/ISO 1940 ausgewuchtete GG-Scheiben wie folgt:
 Gütestufe G 6,3 für $\varnothing d_d \leq 400$ mm bei $n = 1500 \text{ min}^{-1}$, für $\varnothing d_d > 400$ mm bei $v = 30 \text{ m/s}$.

Die Auswuchtung wird ohne Nut auf glattem Wuchtdorn vorgenommen. Für Maschinen, deren Läufer mit einer in das Wellenende eingesetzten vollen Passfeder ausgewuchtet sind, muss mit folgendem Vermerk bestellt werden: „Ausgewuchtet mit Fertigbohrung und leerer Nut auf glattem Wuchtdorn ohne eingesetzte Passfeder“.

Ein Auswuchten in zwei Ebenen Gütestufe G 6,3 oder feiner ist erforderlich, wenn $v \geq 30 \text{ m/s}$ oder das Verhältnis Richtdurchmesser zu Kranzbreite $d_d : b_d < 4$ ist bei $v > 20 \text{ m/s}$.

Mehrpreis auf Anfrage nach Bekanntgabe der Betriebsdrehzahl.

Balancing

The list prices apply, as per VDI 2060, to cast iron pulleys balanced in one plane as follows:
 Grade G 6.3 for $\varnothing d_d \leq 400$ mm at $n = 1500 \text{ rpm}$, for $\varnothing d_d > 400$ mm at $v = 30 \text{ m/sec}$.

Balancing is carried out minus the key on a smooth mandrel. Machines where the rotors are balanced with an adjusting spring inserted in the shaft end must be ordered as follows: "Balanced with finished bore without key on a smooth mandrel without inserted spring".

We recommend balancing in two planes grade G 6.3 or better if $v \geq 30 \text{ m/sec}$. or if the ratio between datum diameter and pulley face width $d_d : b_d < 4$ at $v > 20 \text{ m/sec}$.

Surcharges for balancing on request. Please give pulley operating speed.

Aufschläge für Fertigbohrung H7 und Passfedernut nach DIN 6885 Teil 1
Surcharges for finished bore H7 and keyway to DIN 6885 part 1

Stück Quantity	Fertigbohrung bis 30 mm Finished bore up to 30 mm		Fertigbohrung 31 bis 50 mm Finished bore 31 to 50 mm		Fertigbohrung 51 bis 75 mm Finished bore 51 to 75 mm		Gewindebohrung für Stellschraube Drilled and tapped for setscrews
	ohne Nut without keyway	mit Nut with keyway	ohne Nut without keyway	mit Nut with keyway	ohne Nut without keyway	mit Nut with keyway	
	Fr. Stück each	Fr. Stück each	Fr. Stück each	Fr. Stück each	Fr. Stück each	Fr. Stück each	
1 bis to 2	118,08	147,68	169,28	205,60	210,88	264,16	59,68
3 bis to 5	101,92	128,16	146,08	177,28	182,56	228,64	48,64
6 bis to 10	87,36	110,88	127,36	153,76	158,40	198,56	41,12
11 bis to 24	82,08	108,32	118,08	143,52	146,88	184,32	36,80
25 bis to 50	74,24	94,88	108,64	131,04	134,88	169,28	32,96
über over 50	69,76	87,36	100,80	121,92	125,12	157,76	31,04

Sonderbearbeitungen und Sonderscheiben auf Anfrage. *Special pulleys and custom designed pulleys on request.*

Profil Profile SPZ/10														
Richtdurchmesser Datum diameter d_1 (mm)	Anzahl der Rillen No. of grooves	Ausführung Type		Gewicht ohne Buchse Weight without bushing (\approx kg)	Taper-Buchse Taper bushing	Fr. Stück ohne Buchse each without bushing	Richtdurchmesser Datum diameter d_1 (mm)	Anzahl der Rillen No. of grooves	Ausführung Type		Gewicht ohne Buchse Weight without bushing (\approx kg)	Taper-Buchse Taper bushing	Fr. Stück ohne Buchse each without bushing	
50▲	1	●	11	0,3	1008	34,88	118	1	●	8	0,9	1610	45,76	
	2	●	11	0,4	1008	42,56		2	●	6	1,3	1610	51,04	
56▲	1	●	11	0,4	1008	27,84		3	●	6	1,6	2012	63,68	
	2	●	11	0,5	1108	32,00		4	●	6	1,8	2012	72,00	
60	1	●	11	0,2	1008	28,64		5	●	6	1,8	2012	89,76	
	2	●	11	0,6	1108	34,72		6*	●	6	2,0	2517	94,72	
63	1	●	8	0,2	1108	29,76		125	1	●	8	1,0	1610	48,64
	2	●	6	0,3	1108	34,88			2	●	6	1,4	1610	53,28
	3	●	6	0,4	1108	44,64			3	●	2	1,8	2012	65,44
4	●	6	0,4	1108	44,64	4			●	2	2,2	2012	77,60	
67	1	●	8	0,3	1108	29,92		5	●	6	2,3	2012	91,36	
	2	●	6	0,4	1108	36,32		6*	●	6	2,5	2517	99,04	
	3	●	6	0,5	1108	45,76	132	1	●	8	1,1	1610	51,04	
71	1	●	8	0,3	1108	30,40		2	●	6	1,5	1610	54,08	
	2	●	6	0,4	1108	37,12		3	●	2	2,3	2012	67,36	
	3	●	6	0,6	1108	47,04		4	●	2	2,5	2012	79,84	
75	1	●	8	0,4	1108	31,68	5	●	6	2,7	2517	92,80		
	2	●	6	0,4	1210	37,44	6*	●	6	2,9	2517	102,72		
	3	●	6	0,5	1210	47,68	140	1	●	8	1,2	1610	52,48	
80	1	●	8	0,5	1210	32,00		2	●	2	1,7	1610	58,56	
	2	●	6	0,6	1210	38,72		3	●	2	2,6	2012	71,36	
	3	●	6	0,7	1210	48,64		4	●	2	2,9	2012	82,08	
85	1	●	8	0,6	1210	32,64	5	●	2	3,2	2517	95,52		
	2	●	6	0,5	1610	38,88	6*	●	2	3,5	2517	106,24		
	3	●	6	0,6	1610	49,92	8*	●	4	4,0	2517	193,92		
90	1	●	8	0,7	1210	33,28	150	1	●	8	1,2	1610	55,04	
	2	●	6	0,7	1610	40,00		2	●	8	2,0	2012	64,32	
	3	●	6	0,8	1610	51,04		3	●	2	3,1	2012	74,88	
	4	●	6	1,0	1610	64,32		4	●	2	3,7	2517	87,04	
	5	●	6	1,2	1610	73,12		5	●	2	4,0	2517	102,88	
95	1	●	8	0,7	1210	37,12	6*	●	2	4,4	2517	116,00		
	2	●	6	0,8	1610	40,96	8*	●	4	5,1	2517	201,92		
	3	●	6	0,9	1610	51,36	160	1	●	8	1,3	1610	58,72	
	4	●	6	1,1	1610	65,76		2	●	8	2,5	2012	69,92	
	5	●	6	1,3	1610	74,88		3	●	2	3,6	2012	85,44	
100	1	●	8	0,8	1210	38,88		4	●	2	4,4	2517	111,04	
	2	●	6	0,9	1610	44,00		5	●	2	4,8	2517	130,56	
	3	●	6	1,1	1610	54,24	6*	●	2	5,2	2517	144,64		
106	1	●	8	0,9	1610	39,68	8*	●	4	5,6	2517	219,04		
	2	●	6	1,1	1610	47,04	170	1	●	8	1,5	1610	63,04	
	3	●	6	1,1	1610	66,56		2	●	8	2,5	2012	82,24	
	4	●	6	1,1	1610	66,56		3	○	9	4,2	2012	96,80	
	5	●	6	1,3	2012	78,40		4	●	2	5,3	2517	124,00	
6*	●	6	1,4	2012	81,28	5		●	2	5,9	2517	147,84		
112	1	●	8	1,0	1610	43,04	6*	●	2	6,5	2517	173,76		
	2	●	6	1,3	1610	48,64	180	1	●	8	1,6	1610	69,44	
	3	●	6	1,3	2012	58,56		2	●	8	2,5	2012	82,72	
	4	●	6	1,5	2012	70,24		3	○	9	4,8	2012	93,12	
	5	●	6	1,8	2012	86,24		4	○	9	6,1	2517	125,44	
	6*	●	6	1,6	2012	87,68		5	○	9	6,3	2517	136,32	
118	1	●	8	1,0	1610	43,04		6*	○	9	6,8	2517	152,64	
	2	●	6	1,3	1610	48,64	8*	●	4	7,1	3020	230,08		
	3	●	6	1,3	2012	58,56	190	1	●	8	1,8	1610	69,92	
	4	●	6	1,5	2012	70,24		2	●	8	2,6	2012	92,00	
	5	●	6	1,8	2012	86,24		3	○	9	4,9	2012	104,00	
	6*	●	6	1,9	2012	91,36		4	○	9	5,3	2517	128,16	
125	1	●	8	1,0	1610	48,64		5	○	9	6,3	2517	160,64	
	2	●	6	1,4	1610	53,28		6*	○	9	6,9	2517	188,64	
▲ nur für Profil 10 only for profile 10														

Anzahl der Rillen No. of grooves z	1	2	3	4	5	6	8
Kranzbreite Face width b_2 (mm)	16	28	40	52	64	76	100
Taper-Buchse Taper bushing	1008	1108	1210	1610	2012	2517	3020
Bohrung d_2 (mm) von ... bis ... Bore d_2 (mm) from ... to ...	10-25	10-28	11-32	14-42	14-50	16-60	25-75
Fr./Stück each	12,48	12,96	18,40	20,80	24,64	37,60	50,24

● Vollscheibe Solid pulley
 ○ Bodenscheibe Plate pulley (mit oder ohne Spiegel with or without holes)
 × Armscheibe Spoked pulley
 Material: EN-GJL 200 – DIN EN 1561
 * Keine Lagerware Non stock items

Bohrungsdurchmesser d_2 siehe Seite 3.
 Bore diameters d_2 see page 3.

Profil Profile SPZ/10

Richtdurchmesser Datum diameter d ₂ (mm)	Anzahl der Rillen No. of grooves	Ausführung Type		Gewicht ohne Buchse Weight without bushing (≈ kg)	Taper-Buchse Taper bushing	Fr. Stück ohne Buchse each without bushing	Richtdurchmesser Datum diameter d ₂ (mm)	Anzahl der Rillen No. of grooves	Ausführung Type		Gewicht ohne Buchse Weight without bushing (≈ kg)	Taper-Buchse Taper bushing	Fr. Stück ohne Buchse each without bushing			
200	1	●	8	2,3	2012	78,24	500	2	x	7	9,1	2517	327,36			
	2	●	8	2,8	2012	88,00		3	x	7	11,4	2517		374,24		
	3	○	9	3,5	2012	110,56		4	x	10	14,3	3020				
	4	○	9	4,7	2517	129,92		5	x	10	17,6	3020				
	5	○	9	5,5	2517	146,72		6*	x	10	19,9	3020				
	6*	○	9	6,1	2517	163,20		630	3*	x	7	15,9			2517	
	8*	●	4	9,3	3020	249,28			4*	x	10	20,0			3020	
	224	1	○	5	2,5	2012			91,20	5*	x	10			22,7	3020
2		○	5	3,2	2012	108,32			6*	x	7	33,6			3535	
3		○	9	3,9	2012	126,40										
4		○	9	5,2	2517	155,52										
5		○	9	6,0	2517	175,36										
6*		○	9	6,6	2517	207,84										
8*		●	4	11,8	3020	281,12										
250		1	x	7	2,8	2012		105,44								
	2	x	7	3,5	2012	125,12										
	3	x	10	4,3	2012	150,56										
	4	x	10	5,7	2517	170,72										
	5	x	10	6,4	2517	194,08										
	6*	x	10	7,0	2517	210,08										
	8*	x	10	10,5	3020	247,68										
	280	1	x	7	2,9	2012	135,52									
2		x	7	4,0	2012	140,48										
3		x	7	5,3	2517	163,36										
4		x	10	6,4	2517	192,96										
5		x	10	7,1	2517	225,76										
6*		x	10	7,8	2517	248,16										
8*		x	10	10,8	3020	289,60										
315		1	x	7	3,1	2012	164,16									
	2	x	7	4,2	2012	165,76										
	3	x	7	6,1	2517	192,96										
	4	x	10	7,6	2517	234,24										
	5	x	10	8,6	2517	260,16										
	6*	x	10	9,3	2517	322,08										
355	1	x	7	3,5	2012	161,60										
	2	x	7	5,1	2012	181,28										
	3	x	7	7,3	2517	229,60										
	4	x	10	8,9	2517	298,56										
	5	x	10	10,0	2517	336,32										
	6*	x	10	10,7	2517	441,92										
	8*	x	10	16,0	3030	636,32										
	400	1	x	7	6,0	2012	187,68									
2		x	7	6,3	2517	229,60										
3		x	7	8,0	2517	277,76										
4		x	10	10,1	2517	345,60										
5		x	10	11,7	3020	389,60										
6*		x	10	14,5	3020	516,32										
8*		x	10	18,2	3030	691,20										
450		1	x	7	6,1	2517	259,52									
	2	x	7	8,2	2517	298,56										
	3	x	7	9,8	2517	324,64										
	4	x	10	11,8	3020	372,96										
	5	x	10	13,9	3020	422,56										
	6*	x	10	16,9	3030	577,60										
	8*	x	10	24,0	3535	798,56										

Anzahl der Rillen No. of grooves z	1	2	3	4	5	6	8
Kranzbreite Face width b ₂ (mm)	16	28	40	52	64	76	100

Taper-Buchse Taper bushing	2012	2517	3020	3030	3535
Bohrung d ₂ (mm) von ... bis ... Bore d ₂ (mm) from ... to ...	14-50	16-60	25-75	35-75	35-90
Fr./Stück each	24,64	37,60	50,24	66,08	127,04

- Vollscheibe Solid pulley
 - Bodenscheibe Plate pulley (mit oder ohne Spiegel with or without holes)
 - × Armscheibe Spoked pulley
- Material: EN-GJL 200 – DIN EN 1561
 * Keine Lagerware Non stock items

Bohrungsdurchmesser d₂ siehe Seite 3.
 Bore diameters d₂ see page 3.

Profil Profile SPA/13														
Richtdurchmesser Datum diameter d_1 (mm)	Anzahl der Rillen No. of grooves	Ausführung Type		Gewicht ohne Buchse Weight without bushing (\approx kg)	Taper-Buchse Taper bushing	Fr. Stück ohne Buchse each without bushing	Richtdurchmesser Datum diameter d_1 (mm)	Anzahl der Rillen No. of grooves	Ausführung Type		Gewicht ohne Buchse Weight without bushing (\approx kg)	Taper-Buchse Taper bushing	Fr. Stück ohne Buchse each without bushing	
63▲	1	●	11	0,6	1108	34,40	140	1	●	8	1,8	1610	50,88	
	2	●	11	0,8	1108	45,76		2	●	2	2,0	2012	63,52	
67▲	1	●	8	0,3	1108	29,76	140	3	●	2	2,8	2517	86,24	
	2	●	6	0,5	1108	32,48		4	●	2	3,1	2517	94,88	
								5	●	2	3,4	2517	99,84	
71▲	1	●	8	0,3	1108	30,72	150	1	●	8	1,4	1610	53,12	
	2	●	6	0,5	1108	33,60		2	●	2	2,4	2012	71,04	
	3	●	6	0,7	1108	42,24		3	●	2	3,5	2517	91,68	
75▲	1	●	8	0,4	1108	31,20	150	4	●	2	3,8	2517	100,32	
	2	●	6	0,6	1108	36,00		5	●	2	4,2	2517	112,16	
	3	●	6	0,8	1108	58,72								
80▲	1	●	8	0,5	1210	31,20	160	1	○	5	1,9	1610	54,88	
	2	●	6	0,6	1210	35,36		2	●	2	2,9	2012	78,88	
	3	●	6	0,9	1210	45,28		3	●	2	3,9	2517	96,00	
85	1	●	8	0,6	1210	32,16	160	4	●	2	4,4	2517	115,20	
	2	●	6	0,7	1210	37,28		5	●	2	5,1	2517	130,40	
	3	●	6	1,0	1210	47,20								
90	1	●	8	0,7	1210	33,12	170	1	○	5	2,0	1610	64,00	
	2	●	6	0,7	1610	37,92		2	●	2	3,1	2012	94,88	
	3	●	6	1,0	1610	48,80		3	●	2	4,6	2517	118,56	
95	4	●	6	1,2	1615	58,56	170	4	●	2	5,5	2517	135,04	
	1	●	8	0,8	1210	35,04		5	●	2	5,9	3020	141,60	
	2	●	6	0,9	1610	39,68		180	1	○	5	2,1	1610	64,48
	3	●	6	1,1	1610	51,20			2	●	9	3,4	2012	97,60
4	●	6	1,4	1615	59,52	3	●		2	5,1	2517	120,80		
100	1	●	8	0,8	1610	36,96	180	4	●	2	5,9	2517	136,64	
	2	●	6	0,9	1610	42,56		5	●	2	6,2	3020	158,88	
	3	●	2	1,2	1610	53,12		190	1	○	5	2,3	1610	81,44
	4	●	2	1,7	1610	64,64			2	○	9	3,8	2012	103,84
	5	●	6	1,9	1610	76,00			3	●	2	5,4	2517	129,60
106	1	●	8	0,9	1610	39,36	190	4	●	2	6,8	2517	157,28	
	2	●	6	1,1	1610	44,32		5	●	2	7,4	3020	174,88	
	3	●	2	1,4	1610	55,36		200	1	○	5	2,6	2012	73,60
	4	●	6	2,0	2012	65,92			2	○	5	4,1	2517	109,12
	5	●	6	2,0	2012	78,24			3	○	9	4,9	2517	130,56
112	1	●	8	1,0	1610	41,60	200	4	●	2	7,4	3020	145,92	
	2	●	6	1,2	1610	47,20		5	●	4	8,4	3020	168,80	
	3	●	6	1,3	2012	57,76		212	1	○	5	2,7	2012	92,32
	4	●	6	1,9	2012	67,68			2	○	5	4,3	2517	125,28
	5	●	6	2,1	2012	82,08			3	○	9	5,2	2517	143,04
118	1	●	8	1,2	1610	43,68	212	4	●	2	7,3	3020	167,20	
	2	●	6	1,4	1610	48,80		5	●	2	8,2	3020	191,20	
	3	●	2	1,8	2012	59,52		224	1	x	7	2,7	2012	100,00
	4	●	2	2,0	2012	71,36			2	○	5	4,4	2517	133,92
	5	●	2	2,4	2012	85,60			3	○	9	5,5	2517	154,56
125	1	●	8	1,4	1610	45,92	224	4	●	2	7,4	3020	187,84	
	2	●	2	1,7	1610	51,20		5	●	2	8,3	3020	214,24	
	3	●	2	2,0	2012	62,24		236	1	x	7	2,8	2012	113,44
	4	●	2	2,5	2012	73,44			2	○	5	4,6	2517	147,68
	5	●	2	2,7	2012	87,36			3	○	9	5,7	2517	171,52
132	1	●	8	1,6	1610	47,84	236	4	●	2	7,8	3020	208,32	
	2	●	2	1,8	2012	54,56		5	●	2	8,7	3020	235,68	
	3	●	2	2,3	2012	64,80		250	1	x	7	2,9	2012	124,64
	4	●	2	2,6	2517	77,12			2	x	7	4,8	2517	154,56
	5	●	2	2,9	2517	88,48			3	○	9	5,9	2517	182,24
▲ nur für Profil 13 only for profile 13														

Anzahl der Rillen No. of grooves z	1	2	3	4	5
Kranzbreite Face width b_2 (mm)	20	35	50	65	80

Taper-Buchse Taper bushing	1108	1210	1610	1615	2012	2517	3020	3535
Bohrung d_2 (mm) von ... bis ... Bore d_2 (mm) from ... to ...	10-28	11-32	14-42	14-42	14-50	16-60	25-75	35-90
Fr./Stück each	12,96	18,40	20,80	23,04	24,64	37,60	50,24	127,04

- Vollscheibe Solid pulley
 - Bodenscheibe Plate pulley (mit oder ohne Spiegel with or without holes)
 - × Armscheibe Spoked pulley
- Material: EN-GJL 200 – DIN EN 1561

Bohrungsdurchmesser d_2 siehe Seite 3.
 Bore diameters d_2 see page 3.

Profil Profile SPA/13

Richtdurchmesser Datum diameter d_2 (mm)	Anzahl der Rillen No. of grooves	Ausführung Type		Gewicht ohne Buchse Weight without bushing (\approx kg)	Taper-Buchse Taper bushing	Fr. Stück ohne Buchse each without bushing	Richtdurchmesser Datum diameter d_2 (mm)	Anzahl der Rillen No. of grooves	Ausführung Type		Gewicht ohne Buchse Weight without bushing (\approx kg)	Taper-Buchse Taper bushing	Fr. Stück ohne Buchse each without bushing
280	1	x	7	3,3	2012	139,52	450	1	x	7	7,0	2012	241,44
	2	x	7	5,4	2517	182,40		2	x	7	10,3	2517	314,40
	3	O	9	6,7	2517	212,32		3	x	7	14,1	3020	348,96
	4	O	9	8,8	3020	260,80		4	x	10	15,5	3020	409,12
	5	O	5	15,5	3535	303,68		5	x	7	24,3	3535	532,48
315	1	x	7	3,6	2012	170,56	500	1	x	7	8,0	2517	298,40
	2	x	7	6,0	2517	208,32		2	x	7	11,6	2517	345,44
	3	O	5	8,3	3020	245,44		3	x	7	16,0	3020	379,52
	4	O	9	9,7	3020	301,92		4	x	10	18,2	3020	455,84
	5	O	5	17,0	3535	352,48		5	x	7	27,3	3535	606,56
355	1	x	7	4,2	2012	190,08	560	1	x	7	11,6	2517	356,48
	2	x	7	6,7	2517	247,36		2	x	7	15,5	3020	451,20
	3	x	7	9,2	3020	300,80		3	x	7	17,8	3020	566,08
	4	x	10	11,0	3020	360,32		4	x	7	26,7	3535	662,08
	5	x	7	18,6	3535	422,56		5	x	7	30,4	3535	804,16
400	1	x	7	4,9	2012	187,04	630	1	x	7	10,1	2517	403,04
	2	x	7	8,1	2517	218,40		2	x	7	16,0	3020	580,48
	3	x	7	11,0	3020	294,40		3	x	7	22,0	3020	642,56
	4	x	10	12,8	3020	351,84		4	x	7	30,8	3535	771,04
	5	x	7	21,0	3535	470,24		5	x	7	33,7	3535	985,28

Anzahl der Rillen No. of grooves z	1	2	3	4	5
Kranzbreite Face width b_2 (mm)	20	35	50	65	80

Taper-Buchse Taper bushing	2012	2517	3020	3535
Bohrung d_2 (mm) von ... bis ... Bore d_2 (mm) from ... to ...	14-50	16-60	25-75	35-90
Fr./Stück each	24,64	37,60	50,24	127,04

- Vollscheibe Solid pulley
- O Bodenscheibe Plate pulley (mit oder ohne Spiegel with or without holes)
- × Armscheibe Spoked pulley

Material: EN-GJL 200 – DIN EN 1561

Bohrungsdurchmesser d_2 siehe Seite 3.
 Bore diameters d_2 see page 3.

Profil Profile SPB/17														
Richtdurchmesser Datum diameter d_3 (mm)	Anzahl der Rillen No. of grooves	Ausführung Type		Gewicht ohne Buchse Weight without bushing (\approx kg)	Taper-Buchse Taper bushing	Fr. Stück ohne Buchse each without bushing	Richtdurchmesser Datum diameter d_3 (mm)	Anzahl der Rillen No. of grooves	Ausführung Type		Gewicht ohne Buchse Weight without bushing (\approx kg)	Taper-Buchse Taper bushing	Fr. Stück ohne Buchse each without bushing	
100▲	1	●	1	0,9	1610	53,12	200	1	●	8	5,0	2012	95,20	
	2	●	6	1,2	1610	56,48		2	●	8	5,4	2517	138,56	
	3	●	6	1,7	1610	65,92		3	●	2	6,5	2517	157,44	
112▲	1	●	1	1,1	1610	54,08		4	●	2	8,8	3020	182,24	
	2	●	6	1,5	1610	58,56		5	●	2	9,1	3020	206,40	
	3	●	6	2,0	1610	67,04		6	●	4	10,3	3020	229,76	
118▲	1	●	1	1,3	1610	55,36		8	●	4	13,5	3535	339,68	
	2	●	6	1,7	1610	59,68		212	1	●	8	4,2	2012	102,24
	3	●	6	2,3	1610	68,96			2	●	8	4,9	2517	143,36
125▲	1	●	1	1,5	1610	56,48	3		●	2	6,0	2517	170,72	
	2	●	2	1,9	2012	60,96	4	●	2	9,8	3020	193,92		
	3	●	2	2,4	2012	71,36	5	●	2	11,0	3020	214,24		
	4	●	4	3,0	2012	81,44	6	●	4	14,3	3535	268,80		
	5	●	6	3,5	2012	100,96	8	●	4	16,6	3535	387,04		
132▲	1	●	1	1,8	1610	60,48	224	1	●	8	4,7	2012	113,44	
	2	●	2	2,2	2012	66,56		2	●	8	5,3	2517	152,48	
	3	●	2	2,8	2012	78,40		3	●	2	6,3	2517	182,40	
	4	●	4	3,4	2012	100,00		4	●	2	11,3	3020	224,00	
	5	●	4	3,7	2012	107,84		5	●	2	12,7	3020	257,12	
140	1	●	1	2,3	1610	60,96		6	●	4	17,0	3535	308,96	
	2	●	2	2,7	2012	68,48		8	●	4	19,3	3535	428,16	
	3	●	2	3,3	2012	87,52		10	●	4	21,8	3535	557,12	
	4	●	2	3,7	2517	105,12		236	1	●	8	5,0	2012	123,68
	5	●	2	4,5	2517	118,88			2	●	8	5,5	2517	165,76
	6	●	4	4,6	2517	133,60			3	x	10	7,0	2517	199,52
150	1	●	1	2,7	1610	64,64	4		x	10	14,5	3020	245,44	
	2	●	2	3,1	2012	75,84	5	●	6	16,9	3535	282,24		
	3	●	2	3,9	2517	94,88	6	●	4	20,0	3535	334,88		
	4	●	2	4,4	2517	118,88	8	●	4	22,3	3535	465,28		
	5	●	4	5,2	2517	137,76	10	●	4	25,3	3535	602,88		
	6	●	4	5,6	2517	159,04	250	1	●	8	5,4	2012	136,80	
160	1	●	1	2,5	1610	66,56		2	x	7	5,5	2517	185,28	
	2	●	2	2,9	2012	85,76		3	●	2	7,7	3020	220,00	
	3	●	2	4,2	2517	110,24		4	●	2	19,6	3020	255,04	
	4	●	4	4,9	2517	129,76		5	●	4	21,7	3535	307,68	
	5	●	4	6,0	2517	153,92		6	●	4	23,3	3535	358,24	
	6	●	4	5,4	3020	164,80	8	●	4	27,5	3535	526,88		
170	1	●	1	2,9	1610	70,72	265	10	●	4	29,3	3535	662,88	
	2	●	2	3,3	2012	95,04		2	●	7	6,2	2517	202,56	
	3	●	2	4,9	2517	120,16		3	○	9	8,0	3020	243,36	
	4	●	4	5,7	2517	146,56		4	○	9	9,5	3020	282,24	
	5	●	4	6,1	3020	167,04		6	○	9	16,7	3525	387,52	
	6	●	4	6,5	3020	185,44		8	○	9	24,0	3525	562,72	
	8	●	4	8,0	3020	229,76		280	1	x	7	6,1	2012	190,40
	180	1	●	1	4,1	1610			78,56	2	x	7	6,8	2517
2		●	8	4,5	2517	109,76	3		x	10	8,6	3020	246,56	
3		●	2	5,5	2517	133,28	4		○	9	10,1	3020	311,68	
4		●	4	6,9	2517	164,32	5		○	9	17,8	3535	360,32	
5		●	4	7,1	3020	188,32	6		○	9	19,6	3535	412,80	
6		●	4	7,7	3020	212,32	8	○	9	26,7	3535	588,00		
190	8	●	4	9,5	3020	268,64	10	○	9	30,5	3535	773,12		
	200	1	●	8	4,6	2012	91,68	300	2	x	7	7,3	2517	216,00
		2	●	8	5,0	2517	124,96		3	x	10	9,2	3020	268,80
		3	●	2	6,3	2517	136,96		4	○	9	14,3	3020	309,60
		4	●	4	7,6	2517	174,56		5	○	9	18,2	3535	346,56
		5	●	4	8,1	3020	196,64		6	○	9	21,9	3535	424,48
		6	●	4	9,2	3020	220,00		8	○	9	26,2	3535	652,96
		8	●	4	11,2	3030	314,08							

▲ nur für Profil 17 only for profile 17

Anzahl der Rillen No. of grooves z	1	2	3	4	5	6	8	10
Kranzbreite Face width b_2 (mm)	25	44	63	82	101	120	158	196

Taper-Buchse Taper bushing	1610	2012	2517	3020	3030	3535
Bohrung d_2 (mm) von ... bis ... Bore d_2 (mm) from ... to ...	14-42	14-50	16-60	25-75	35-75	35-90
Fr./Stück each	20,80	24,64	37,60	50,24	66,08	127,04

- Vollscheibe Solid pulley
 - Bodenscheibe Plate pulley (mit oder ohne Spiegel with or without holes)
 - × Armscheibe Spoked pulley
- Material: EN-GJL 200 – DIN EN 1561

Bohrungsdurchmesser d_2 siehe Seite 3.
 Bore diameters d_2 see page 3.

Profil Profile SPB/17

Richtdurchmesser Datum diameter d_a (mm)	Anzahl der Rillen No. of grooves	Ausführung Type		Gewicht ohne Buchse Weight without bushing (\approx kg)	Taper-Buchse Taper bushing	Fr. Stück ohne Buchse each without bushing	Richtdurchmesser Datum diameter d_a (mm)	Anzahl der Rillen No. of grooves	Ausführung Type		Gewicht ohne Buchse Weight without bushing (\approx kg)	Taper-Buchse Taper bushing	Fr. Stück ohne Buchse each without bushing		
315	1	x	7	7,2	2012	241,44	560	2	x	7	16,5	3030	535,36		
	2	x	7	7,8	2517	251,20		3	x	7	25,9	3535	679,68		
	3	x	10	9,6	3020	290,24		4	x	7	29,0	3535	786,72		
	4	O	5	17,1	3535	358,24		5	x	7	35,3	4040	967,84		
	5	O	9	18,8	3535	420,64		6	x	10	43,1	4040	1.119,68		
	6	O	9	23,0	3535	517,92		8	x	10	49,0	4545	1.552,64		
	8	O	9	26,0	3535	665,92		10*	x	10	55,7	4545	1.814,88		
	10	O	9	31,5	3535	870,40		630	2	x	7	18,5	3020	680,32	
	335	2	x	7	7,8	2517			272,64	3	x	7	28,9	3535	771,04
		3	x	10	10,5	3020			321,44	4	x	7	33,3	3535	924,96
4		x	7	18,3	3535	372,00	5		x	7	43,1	4040	1.111,84		
5		x	10	19,5	3535	436,16	6		x	10	49,2	4040	1.302,72		
6		x	10	22,0	3535	570,56	8		x	10	62,0	4545	1.788,96		
8		x	10	28,2	3535	761,44	10*		x	10	72,0	4545	2.091,36		
10*		x	10	36,0	4040	923,04	710		3	x	7	33,2	3535	905,44	
355		2	x	7	8,7	3020			297,92	4	x	7	39,1	3535	1.069,12
		3	x	10	10,8	3020			358,24	5	x	7	50,2	4040	1.353,28
		4	x	7	18,6	3535		426,56	6	x	10	62,3	4545	1.538,40	
	5	x	10	20,8	3535	506,24		8	x	10	71,0	4545	2.028,96		
	6	O	9	22,8	3535	603,68		10*	x	10	80,0	4545	2.412,64		
	8	x	10	27,0	3535	780,80		800	3	x	7	36,7	3535	1.254,08	
	10*	x	10	38,0	4040	999,04			4	x	7	48,8	4040	1.425,28	
	375	2	x	7	9,5	3020			331,04	5	x	7	56,1	4040	1.760,32
		3	x	10	11,5	3020			405,12	6	x	10	71,4	4545	1.959,04
		4	x	10	16,5	3525	482,88		8	x	10	90,9	4545	2.469,12	
6		x	10	25,0	3535	673,76	10*		x	10	102,0	4545	2.846,88		
8		x	10	28,0	4040	855,20	900		3	x	7	46,8	3535	1.544,48	
400		2	x	7	10,0	3020			354,56	4	x	7	60,0	4040	1.900,48
		3	x	7	18,3	3535			436,16	5	x	7	74,8	4545	2.073,92
		4	x	7	20,5	3535			516,00	6	x	10	81,5	4545	2.665,76
		5	x	10	23,4	3535		607,68	8	x	10	110,0	4545	3.032,00	
		6	x	10	25,1	3535		716,48	10*	x	10	126,0	5050	3.711,52	
	8	x	10	36,5	4040	936,80		1000	3	x	7	56,5	4040	2.099,20	
	10*	x	10	41,0	4040	1.215,04			4	x	7	66,5	4040	2.406,88	
	425	2	x	7	11,5	3020			381,60	5	x	7	80,5	4545	2.702,88
		3	x	7	18,0	3535			479,04	6	x	10	90,0	4545	3.193,44
		4	x	7	19,5	3535	568,64		8	x	10	132,0	5050	3.832,32	
6		x	10	25,1	4040	788,80	10*		x	10	147,0	5050	4.517,60		
8		x	10	52,5	4545	1.061,28	450		2	x	7	12,1	3020	410,88	
450		2	x	7	12,1	3020			410,88	3	x	7	21,9	3535	521,92
		3	x	7	21,9	3535			521,92	4	x	7	24,5	3535	619,20
		4	x	7	24,5	3535			619,20	5	x	10	27,3	3535	741,92
		5	x	10	27,3	3535		741,92	6	x	10	35,5	4040	862,72	
		6	x	10	35,5	4040		862,72	8	x	10	40,9	4040	1.153,12	
	8	x	10	40,9	4040	1.153,12		10*	x	10	53,5	4545	1.400,16		
	10*	x	10	53,5	4545	1.400,16		500	2	x	7	13,2	3020	461,44	
	500	2	x	7	13,2	3020			461,44	3	x	7	23,1	3535	599,68
		3	x	7	23,1	3535			599,68	4	x	7	26,6	3535	695,20
		4	x	7	26,6	3535	695,20		5	x	10	29,9	3535	852,80	
5		x	10	29,9	3535	852,80	6		x	10	38,9	4040	964,16		
6		x	10	38,9	4040	964,16	8		x	10	45,5	4040	1.304,80		
8		x	10	45,5	4040	1.304,80	10*		x	10	61,0	4545	1.585,12		
10*		x	10	61,0	4545	1.585,12	550		2	x	7	14,3	3020	474,40	
550		2	x	7	14,3	3020			474,40	3	x	7	24,1	3535	615,68
		3	x	7	24,1	3535			615,68	4	x	7	27,6	3535	712,00
		4	x	7	27,6	3535		712,00	5	x	10	30,9	3535	868,80	
	5	x	10	30,9	3535	868,80		6	x	10	39,9	4040	980,16		
	6	x	10	39,9	4040	980,16		8	x	10	46,5	4040	1.308,80		
	8	x	10	46,5	4040	1.308,80		10*	x	10	62,0	4545	1.587,20		
	10*	x	10	62,0	4545	1.587,20		600	2	x	7	15,4	3020	487,40	
	600	2	x	7	15,4	3020			487,40	3	x	7	25,1	3535	628,68
		3	x	7	25,1	3535			628,68	4	x	7	28,6	3535	725,00
		4	x	7	28,6	3535	725,00		5	x	10	31,9	3535	881,80	
5		x	10	31,9	3535	881,80	6		x	10	40,9	4040	993,16		
6		x	10	40,9	4040	993,16	8		x	10	47,5	4040	1.311,80		
8		x	10	47,5	4040	1.311,80	10*		x	10	63,0	4545	1.590,20		
10*		x	10	63,0	4545	1.590,20	650		2	x	7	16,5	3020	500,40	
650		2	x	7	16,5	3020			500,40	3	x	7	26,1	3535	641,68
		3	x	7	26,1	3535			641,68	4	x	7	29,6	3535	738,00
		4	x	7	29,6	3535		738,00	5	x	10	32,9	3535	894,80	
	5	x	10	32,9	3535	894,80		6	x	10	41,9	4040	1.006,16		
	6	x	10	41,9	4040	1.006,16		8	x	10	48,5	4040	1.314,80		
	8	x	10	48,5	4040	1.314,80		10*	x	10	64,0	4545	1.593,20		
	10*	x	10	64,0	4545	1.593,20		700	2	x	7	17,6	3020	513,40	
	700	2	x	7	17,6	3020			513,40	3	x	7	27,1	3535	654,68
		3	x	7	27,1	3535			654,68	4	x	7	30,6	3535	751,00
		4	x	7	30,6	3535	751,00		5	x	10	33,9	3535	907,80	
5		x	10	33,9	3535	907,80	6		x	10	42,9	4040	1.019,16		
6		x	10	42,9	4040	1.019,16	8		x	10	49,5	4040	1.317,80		
8		x	10	49,5	4040	1.317,80	10*		x	10	65,0	4545	1.595,20		
10*		x	10	65,0	4545	1.595,20	750		2	x	7	18,7	3020	526,40	
750		2	x	7	18,7	3020			526,40	3	x	7	28,1	3535	667,68
		3	x	7	28,1	3535			667,68	4	x	7	31,6	3535	764,00
		4	x	7	31,6	3535		764,00	5	x	10	34,9	3535	920,80	
	5	x	10	34,9	3535	920,80		6	x	10	43,9	4040	1.032,16		
	6	x	10	43,9	4040	1.032,16		8	x	10	50,5	4040	1.320,80		
	8	x	10	50,5	4040	1.320,80		10*	x	10	66,0	4545	1.602,20		
	10*	x	10	66,0	4545	1.602,20		800	2	x	7	19,8	3020	539,40	
	800	2	x	7	19,8	3020			539,40	3	x	7	29,1	3535	680,68
		3	x	7	29,1	3535			680,68	4	x	7	32,6	3535	777,00
		4	x	7	32,6	3535	777,00		5	x	10	35,9	3535	933,80	
5		x	10	35,9	3535	933,80	6		x	10	44,9	4040	1.045,16		
6		x	10	44,9	4040	1.045,16	8		x	10	51,5	4040	1.323,80		
8		x	10	51,5	4040	1.323,80	10*		x	10	67,0	4545	1.605,20		
10*		x	10	67,0	4545	1.605,20	850		2	x	7	20,9	30		

Profil Profile SPC/22															
Richtdurchmesser Datum diameter d_1 (mm)	Anzahl der Rillen No. of grooves	Ausführung Type		Gewicht ohne Buchse Weight without bushing (\approx kg)	Taper-Buchse Taper bushing	Fr. Stück ohne Buchse each without bushing	Richtdurchmesser Datum diameter d_1 (mm)	Anzahl der Rillen No. of grooves	Ausführung Type		Gewicht ohne Buchse Weight without bushing (\approx kg)	Taper-Buchse Taper bushing	Fr. Stück ohne Buchse each without bushing		
200▲	3	●	4	9,0	2517	292,80	355	3	O	5	22,9	3535	678,24		
	4	●	4	10,5	3020	341,60		4	O	9	28,3	3535	778,24		
	5	●	4	14,0	3535	409,76		5	O	9	32,5	3535	899,04		
	6	●	4	17,0	3535	460,48		6	O	9	36,0	3535	1.027,68		
212▲	3	●	4	10,0	3020	318,88		10*	8	O	9	67,5	4040	1.306,24	
	4	●	4	12,5	3020	377,76			9	O	9	121,0	4545	1.627,36	
	5	●	4	15,0	3535	453,44			375	3	O	5	23,8	3535	743,84
	6	●	4	18,0	3535	512,48				4	O	9	30,0	3535	868,32
224	2	●	4	8,1	3020	391,68		5		O	9	33,0	3535	987,52	
	3	●	4	11,0	3020	354,56		6		O	9	45,5	4040	1.143,36	
	4	●	4	14,0	3535	438,56		8		O	9	68,0	4545	1.368,32	
	5	●	4	16,2	3535	503,52		400		3	x	7	24,1	3535	797,76
6	●	4	19,0	3535	569,60	4	x			10	28,0	3535	944,96		
8	●	4	24,9	3535	737,76	5	x			10	34,0	3535	1.065,76		
236	3	●	4	12,0	3020	395,68	6			O	9	48,0	4040	1.228,00	
	4	●	4	17,2	3535	485,76	8	O		9	65,0	4545	1.437,92		
	5	●	4	19,1	3535	548,00	10*	9		O	9	88,0	5050	1.834,40	
	6	●	4	20,8	3535	623,20		425		3	x	7	26,0	3535	884,16
8	●	4	25,5	3535	801,76	4			x	10	31,0	3535	943,84		
250	2	●	4	9,8	3020	328,64			5	O	9	45,0	4040	1.077,60	
	3	●	4	14,5	3020	428,64	6		O	9	58,0	4545	1.267,04		
	4	●	4	20,7	3535	536,16	8		O	9	74,0	4545	1.560,16		
	5	●	4	22,8	3535	639,68	450		3	x	7	28,6	3535	925,76	
6	●	4	26,0	3535	664,96	4			x	10	33,5	3535	1.091,36		
8	●	4	29,7	3535	782,08	5			x	10	45,0	4040	1.170,24		
10*	●	4	34,0	4040	1.011,52	6			O	9	61,1	4545	1.365,28		
265	3	●	8	21,2	3535	507,36	8		O	9	78,7	5050	1.757,60		
	4	O	9	24,0	3535	572,00	10*		9	O	9	101,0	5050	1.975,52	
	5	O	9	26,2	3535	677,44			475	3	x	7	40,0	3535	817,28
	6	O	9	29,0	3535	770,08		4		x	10	47,0	3535	1.026,88	
8	O	9	33,3	3535	869,12	5		x		10	47,2	4040	1.196,96		
280	3	●	8	24,0	3535	545,28	6	O		9	62,8	4545	1.407,52		
	4	O	9	29,0	3535	635,20	8	O		9	81,5	5050	1.875,36		
	5	O	9	31,0	3535	728,32	500	3		x	7	30,9	3535	944,48	
	6	O	9	33,8	3535	831,20		4		x	10	39,0	3535	1.146,56	
8	O	9	37,5	3535	939,04	5		x		10	48,7	4040	1.296,64		
10*	O	9	45,0	4040	1.204,48	6		x		10	60,2	4545	1.518,24		
300	3	O	5	21,0	3535	596,48	8	O		9	87,4	5050	1.988,96		
	4	O	9	25,0	3535	688,16	10*	9		O	9	127,0	5050	2.302,40	
	5	O	9	28,5	3535	770,08		560		3	x	7	36,0	3535	1.031,52
	6	O	9	29,0	3535	883,84			4	x	10	50,0	4040	1.386,72	
8	●	4	46,5	4040	1.007,84	5			x	10	63,0	4545	1.579,68		
10*	O	9	53,5	4545	1.211,36	6	x		10	77,0	5050	1.739,52			
315	3	O	5	21,6	3535	633,60	8		x	10	94,0	5050	2.247,36		
	4	O	9	24,6	3535	698,88	10*		9	O	9	115,0	5050	2.523,20	
	5	O	9	29,0	3535	789,76			630	3	x	7	48,5	4040	1.224,80
	6	O	9	31,4	3535	905,76				4	x	7	61,0	4545	1.601,44
8	●	4	50,0	4040	1.090,24	5				x	10	77,0	5050	1.813,44	
10*	O	9	58,0	4545	1.323,20	6	x			10	86,0	5050	2.033,44		
335	3	O	5	22,5	3535	645,92	8			x	10	105,5	5050	2.475,36	
	4	O	9	26,5	3535	758,24	10*			9	O	9	130,0	5050	2.921,28
	5	O	9	30,0	3535	834,72		710		3	x	7	62,5	4040	1.642,72
	6	O	9	35,0	3535	983,20				4	x	7	78,6	4545	2.031,68
8	O	9	58,0	4040	1.193,44	5				x	10	89,6	5050	2.155,36	
							6			x	10	99,4	5050	2.423,36	
							8			x	10	117,5	5050	2.965,28	
							10*			O	9	137,1	5050	3.444,96	

▲ nur für Profil 22 only for profile 22

Anzahl der Rillen No. of grooves z	2	3	4	5	6	8	10
Kranzbreite Face width b_2 (mm)	59,5	85	110,5	136	161,5	212,5	263,5

Taper-Buchse Taper bushing	2517	3020	3535	4040	4545	5050
Bohrung d_2 (mm) von ... bis ... Bore d_2 (mm) from ... to ...	16-60	25-75	35-90	40-100	55-110	70-125
Fr./Stück each	37,60	50,24	127,04	178,56	227,20	347,20

- Vollscheibe Solid pulley
- O Bodenscheibe Plate pulley (mit oder ohne Spiegel with or without holes)
- × Armscheibe Spoked pulley

Material: EN-GJL 200 – DIN EN 1561

* Keine Lagerware Non stock items

Bohrungsdurchmesser d_2 siehe Seite 3.
Bore diameters d_2 see page 3.

Profil Profile SPC/22

Richtdurchmesser Datum diameter d_2 (mm)	Anzahl der Rillen No. of grooves	Ausführung Type		Gewicht ohne Buchse Weight without bushing (\approx kg)	Taper-Buchse Taper bushing	Fr. Stück ohne Buchse each without bushing	Richtdurchmesser Datum diameter d_2 (mm)	Anzahl der Rillen No. of grooves	Ausführung Type		Gewicht ohne Buchse Weight without bushing (\approx kg)	Taper-Buchse Taper bushing	Fr. Stück ohne Buchse each without bushing
800	3	x	7	72,0	4545	1.994,08	1250	5	x	10	177,6	5050	4.394,72
	4	x	7	90,8	5050	2.177,28		6	x	10	201,4	5050	4.936,64
	5	x	10	102,5	5050	2.477,28		8	x	10	243,7	5050	6.100,16
	6	x	10	113,7	5050	2.645,28		10*	O	9	292,1	5050	7.152,00
	8	x	10	136,6	5050	3.187,04							
	10*	O	9	160,7	5050	3.866,88							
1000	5	x	10	134,0	5050	3.247,04							
	6	x	10	150,0	5050	3.686,88							
	8	x	10	181,4	5050	4.746,72							
	10*	O	9	217,2	5050	5.394,40							

Anzahl der Rillen No. of grooves z	3	4	5	6	8	10
Kranzbreite Face width b_2 (mm)	85	110,5	136	161,5	212,5	263,5

Taper-Buchse Taper bushing	4545	5050
Bohrung d_2 (mm) von ... bis ... Bore d_2 (mm) from ... to ...	55-110	70-125
Fr./Stück each	227,20	347,20

- Vollscheibe Solid pulley
 - O Bodenscheibe Plate pulley (mit oder ohne Spiegel with or without holes)
 - × Armscheibe Spoked pulley
- Material: EN-GJL 200 – DIN EN 1561
 * Keine Lagerware Non stock items

Bohrungsdurchmesser d_2 siehe Seite 3.
 Bore diameters d_2 see page 3.

Profil Profile SPZ/10													
Richtdurchmesser Datum diameter d_d (mm)	Anzahl der Rillen No. of grooves	Ausführung Type	Gewicht Weight (\approx kg)	Fertigbohrung Finished bore d_{max} (mm)	Nabellänge Hub length l (mm)	Fr. Stück zentriert each centered	Richtdurchmesser Datum diameter d_d (mm)	Anzahl der Rillen No. of grooves	Ausführung Type	Gewicht Weight (\approx kg)	Fertigbohrung Finished bore d_{max} (mm)	Nabellänge Hub length l (mm)	Fr. Stück zentriert each centered
45▲	1	O	0,2	16	24	15,36	170	1	x	1,7	40	30	45,28
	2	O	0,3	16	35	22,72		2	x	1,9	40	38	66,88
	3	O	0,4	16	35	28,64		3	x	3,0	42	40	91,04
50▲	1	O	0,3	20	24	16,64	180	1	x	2,1	32	30	49,92
	2	O	0,4	20	35	22,72		2	x	3,1	38	38	72,64
	3	O	0,5	20	40	32,00		3	x	3,5	42	40	93,92
56▲	1	O	0,3	20	24	16,64	190	1	x	2,3	35	30	54,56
	2	O	0,5	25	35	22,72		2	x	2,4	35	38	75,68
	3	O	0,7	25	40	32,00		3	x	4,0	35	40	100,00
63	1	O	0,3	25	24	16,64	200	1	x	2,4	32	38	57,76
	2	O	0,6	25	35	22,72		2	x	2,9	38	38	80,32
	3	O	0,9	25	40	33,28		3	x	4,5	42	40	103,20
71	1	O	0,3	25	24	16,64	212	1	x	2,6	35	30	68,16
	2	O	0,6	25	35	24,16		2	x	3,4	35	38	86,56
	3	O	1,0	30	40	34,88		3	x	5,0	38	40	112,16
75	1	O	0,4	24	24	16,64	225	1	x	2,8	32	38	72,64
	2	O	0,6	24	35	25,76		2	x	4,0	38	38	95,52
	3	O	1,1	28	40	39,36		3	x	5,3	42	40	121,12
80	1	O	0,4	25	24	16,64	250	1	x	3,3	32	38	78,88
	2	O	0,7	30	35	27,20		2	x	4,8	38	38	107,68
	3	O	1,1	38	35	41,12		3	x	6,0	42	40	140,96
85	1	O	0,3	25	24	18,24	280	1	x	3,9	35	34	100,00
	2	O	0,7	30	35	32,00		2	x	5,2	42	38	130,40
	3	O	1,1	38	35	44,32		3	x	7,0	48	40	166,72
90	1	O	0,4	25	24	18,24	315	1	x	4,4	35	34	119,68
	2	O	0,8	30	35	33,28		2	x	6,8	42	38	150,08
	3	O	1,2	38	38	45,28		3	x	8,3	48	40	178,88
95	1	O	0,4	28	24	21,28	355	1	x	4,6	35	34	145,60
	2	O	0,8	28	35	34,88		2	x	8,0	42	40	174,24
	3	O	1,2	38	38	48,64		3	x	10,0	48	45	211,36
100	1	O	0,5	28	24	22,72							
	2	O	0,9	30	35	34,88							
	3	O	1,3	38	38	51,52							
106	1	O	0,5	30	24	24,16							
	2	O	1,0	28	35	39,36							
	3	O	1,3	38	38	54,56							
112	1	O	0,5	28	24	25,76							
	2	O	1,0	30	35	42,40							
	3	O	1,4	38	38	57,76							
118	1	O	0,6	28	24	27,20							
	2	O	1,1	38	35	45,28							
	3	O	1,5	38	38	60,80							
125	1	O	0,7	28	24	28,64							
	2	O	1,2	38	35	48,64							
	3	O	1,6	38	40	63,52							
132	1	O	0,8	30	24	33,28							
	2	O	1,3	38	35	49,92							
	3	O	1,6	40	40	66,88							
140	1	O	0,9	28	24	34,88							
	2	O	1,4	38	38	54,56							
	3	O	1,7	38	40	68,16							
150	1	x	1,1	28	24	39,36							
	2	O	1,5	38	38	57,76							
	3	O	1,9	38	40	81,76							
160	1	x	1,2	32	30	44,32							
	2	x	1,6	38	38	62,24							
	3	x	2,4	42	40	91,04							
▲ nur für Profil 10 only for profile 10													

Anzahl der Rillen No. of grooves z	1	2	3
Kranzbreite Face width b_2 (mm)	16	28	40

● Vollscheibe Solid pulley
 ○ Bodenscheibe Plate pulley (mit oder ohne Spiegel with or without holes)
 × Armscheibe Spoked pulley
 Nabellage: einseitig bündig Hub position: one side flush
 Material: EN-GJL 200 – DIN EN 1561

Profil Profile SPA/13

Richtdurchmesser Datum diameter d_d (mm)	Anzahl der Rillen No. of grooves	Ausführung Type	Gewicht Weight (\approx kg)	Fertigbohrung Finished bore d_{max} (mm)	Nabenlänge Hub length l (mm)	Fr. Stück zentriert each centered	Richtdurchmesser Datum diameter d_d (mm)	Anzahl der Rillen No. of grooves	Ausführung Type	Gewicht Weight (\approx kg)	Fertigbohrung Finished bore d_{max} (mm)	Nabenlänge Hub length l (mm)	Fr. Stück zentriert each centered
50▲	1	O	0,3	18	34	16,64	125	1	O	1,4	32	34	34,88
	2	O	0,5	18	49	24,16		2	O	1,9	38	49	49,92
	3	O	0,6	18	47	34,88		3	O	2,6	42	42	65,28
56▲	1	O	0,4	20	34	16,64	4▽	O	3,5	42	53	86,56	
	2	O	0,6	20	49	27,20	5▽	O	4,4	48	65	103,20	
	3	O	0,7	20	47	36,48	132	1	O	1,5	32	34	36,48
63▲	2	O	0,8	25	49	27,20	2	O	2,2	38	49	54,56	
	3	O	0,9	25	47	36,48	3	O	2,6	42	42	72,64	
	4▽	O	1,2	25	60	48,64	4▽	O	3,6	42	53	89,28	
	5▽	O	1,5	25	70	62,24	5▽	O	4,8	48	65	107,68	
	140	1	O	1,5	32	34	41,12	2	O	2,3	38	49	57,76
71▲	2	O	0,9	28	49	30,24	3	O	2,6	42	42	75,68	
	3	O	1,0	32	42	41,12	4▽	O	3,7	42	53	95,52	
	4▽	O	1,5	32	60	50,08	5▽	O	5,0	48	65	112,16	
	5▽	O	1,8	32	70	62,24	150	1	x	1,6	38	36	44,32
	2	x	2,6	38	49	62,24	3	O	3,0	42	42	77,44	
75▲	3	O	1,1	24	42	42,40	4▽	O	4,0	42	53	100,00	
	4▽	O	1,8	24	60	56,00	5▽	O	5,2	48	65	117,92	
	5▽	O	1,9	28	82	65,28	160	1	x	1,8	38	36	48,64
	1	O	0,6	28	34	19,68	2	x	2,4	38	49	68,16	
	2	O	1,0	32	49	32,00	3	x	2,8	42	42	86,56	
80▲	3	O	1,2	38	42	45,76	4▽	O	3,6	48	60	104,64	
	4▽	O	1,9	38	60	56,00	5▽	O	5,5	48	70	121,12	
	5▽	O	2,0	38	55	71,20	170	1	x	2,0	35	36	49,92
	1	O	0,6	24	34	21,28	2	x	2,9	35	49	72,64	
	2	O	1,2	28	49	34,88	3	x	3,2	35	42	91,04	
85	3	O	1,4	28	42	45,28	4▽	x	4,2	35	60	109,28	
	4▽	O	2,0	28	53	59,04	5▽	x	5,8	38	70	137,76	
	5▽	O	2,2	32	55	74,40	180	1	x	2,0	38	36	54,56
	1	O	0,9	28	34	22,72	2	x	3,2	42	49	75,68	
	2	O	1,5	32	49	34,88	3	x	3,6	42	42	95,52	
90	3	O	1,6	38	42	49,92	4▽	x	4,7	48	60	117,92	
	4▽	O	2,2	42	53	63,52	5▽	x	6,1	48	70	143,84	
	5▽	O	2,5	42	67	77,44	190	1	x	2,0	38	36	59,04
	1	O	0,8	28	34	24,16	2	x	3,2	42	49	78,88	
	2	O	1,6	28	49	39,36	3	x	4,0	42	42	103,20	
95	3	O	1,9	28	42	51,52	4▽	x	5,2	48	60	125,92	
	4▽	O	2,5	32	53	68,16	5▽	x	6,3	48	70	151,68	
	5▽	O	2,8	35	67	81,76	200	1	x	2,4	38	36	62,24
	1	O	0,8	28	34	25,76	2	x	2,9	42	49	83,68	
	2	O	1,4	32	49	39,36	3	x	4,2	48	42	106,08	
100	3	O	2,0	38	42	53,12	4▽	x	5,0	55	60	130,40	
	4▽	O	2,7	42	53	68,16	5▽	x	6,5	55	70	157,44	
	5▽	O	3,1	42	60	81,76	212	1	x	2,7	40	36	66,88
	1	O	0,9	28	34	25,76	2	x	3,4	42	49	89,28	
	2	O	1,7	28	49	42,40	3	x	4,4	42	42	121,12	
106	3	O	2,2	32	42	57,76	4▽	x	5,7	42	60	137,76	
	4▽	O	3,2	32	53	72,64	5▽	x	6,9	42	70	172,64	
	5▽	O	3,9	35	60	89,28	225	1	x	2,8	40	36	74,40
	1	O	1,1	28	34	28,64	2	x	3,9	42	49	95,52	
	2	O	1,8	38	49	45,28	3	x	4,6	42	42	124,32	
112	3	O	2,4	38	42	59,04	4▽	x	6,5	42	60	147,04	
	4▽	O	3,4	42	53	75,68	5▽	x	7,3	42	70	180,32	
	5▽	O	4,0	42	60	91,04	236	1	x	3,3	38	36	80,32
	1	O	1,1	32	34	32,00	2	x	4,1	42	49	104,64	
	2	O	1,8	38	49	48,64	3	x	4,9	48	47	136,32	
118	3	O	2,4	42	42	63,52	4▽	x	6,2	55	60	160,64	
	4▽	O	3,4	42	53	80,32	5▽	x	7,5	55	70	195,04	
	5▽	O	4,1	48	65	100,00							

▲ nur für Profil 13 only for profile 13

▽ $d_d + 4$ mm

Anzahl der Rillen No. of grooves z	1	2	3	4	5
Kranzbreite Face width b_2 (mm)	20	35	50	67	82

- Vollscheibe Solid pulley
 - O Bodenscheibe Plate pulley (mit oder ohne Spiegel with or without holes)
 - × Armscheibe Spoked pulley
- Nabenlage: einseitig bündig Hub position: one side flush
 Material: EN-GJL 200 – DIN EN 1561

Profil Profile SPA/13													
Richtdurchmesser Datum diameter d_d (mm)	Anzahl der Rillen No. of grooves	Ausführung Type	Gewicht Weight (\approx kg)	Fertigbohrung Finished bore d_{max} (mm)	Nabenslänge Hub length l (mm)	Fr. Stück zentriert each centered	Richtdurchmesser Datum diameter d_d (mm)	Anzahl der Rillen No. of grooves	Ausführung Type	Gewicht Weight (\approx kg)	Fertigbohrung Finished bore d_{max} (mm)	Nabenslänge Hub length l (mm)	Fr. Stück zentriert each centered
250	1	x	3,4	42	36	83,68	400	1▽	x	6,9	50	50	193,28
	2	x	4,3	48	49	110,56		2▽	x	8,8	55	53	243,84
	3	x	5,3	48	47	145,60		3▽	x	10,5	60	47	303,36
	4▽	x	7,0	55	60	171,20		4▽	x	12,4	60	67	343,20
	5▽	x	7,9	60	70	205,92		5▽	x	15,9	60	82	395,52
280	1	x	3,9	42	44	106,08	450	1▽	x	7,5	55	50	236,64
	2	x	5,4	48	53	134,72		2▽	x	9,4	55	53	283,52
	3	x	6,5	48	47	171,20		3▽	x	12,2	60	47	336,00
	4▽	x	8,5	55	60	211,36		4▽	x	14,2	65	67	392,00
	5▽	x	9,9	60	70	251,04		5▽	x	18,3	65	82	465,92
300	1	x	4,3	48	44	114,88	500	1▽	x	10,5	55	50	280,00
	2	x	5,9	48	53	150,08		2▽	x	10,7	55	55	325,12
	3	x	7,5	55	47	193,28		3▽	x	13,5	60	60	373,92
	4▽	x	9,8	55	60	229,44		4▽	x	16,3	65	67	462,40
	5▽	x	11,3	60	70	260,16		5▽	x	22,8	65	82	502,08
315	1	x	4,8	48	44	128,96	560	1▽	x	14,0	55	60	326,88
	2	x	6,6	48	53	168,32		2▽	x	13,1	55	60	386,56
	3	x	8,8	55	47	209,44		3▽	x	15,6	60	74	453,28
	4▽	x	11,1	55	60	254,72		4▽	x	19,4	65	67	549,12
	5▽	x	12,5	60	70	269,12		5▽	x	24,5	65	82	567,20
355	1	x	5,5	48	44	147,04							
	2	x	7,7	55	53	196,96							
	3	x	9,6	55	47	251,04							
	4▽	x	11,8	55	60	294,40							
	5▽	x	13,8	60	70	346,72							
▽ $d_d + 4$ mm													

Anzahl der Rillen No. of grooves z	1	2	3	4	5
Kranzbreite Face width b_2 (mm)	20	35	50	67	82

● Vollscheibe Solid pulley
 ○ Bodenscheibe Plate pulley (mit oder ohne Spiegel with or without holes)
 × Armscheibe Spoked pulley
 Nabenslage: einseitig bündig Hub position: one side flush
 Material: EN-GJL 200 – DIN EN 1561

Profil Profile SPB/17

Richtdurchmesser Datum diameter d_d (mm)	Anzahl der Rillen No. of grooves	Ausführung Type	Gewicht Weight (\approx kg)	Fertigbohrung Finished bore d_{max} (mm)	Nabenlänge Hub length l (mm)	Fr. Stück zentriert each centered	Richtdurchmesser Datum diameter d_d (mm)	Anzahl der Rillen No. of grooves	Ausführung Type	Gewicht Weight (\approx kg)	Fertigbohrung Finished bore d_{max} (mm)	Nabenlänge Hub length l (mm)	Fr. Stück zentriert each centered
56▲	1	O	0,6	20	41	21,28	132▲	1	O	1,9	30	41	42,40
	2	O	1,0	20	60	33,28		2	O	2,6	30	60	66,88
	3	O	1,1	22	62	48,64		3	O	3,5	42	55	91,04
63▲	1	O	0,8	20	41	21,28	4▽	O	6,3	42	70	113,76	
	2	O	1,2	20	60	33,28	5▽	O	9,4	42	75	142,56	
	3	O	1,2	22	62	49,92	6▽	O	8,5	42	85	180,32	
71▲	1	O	0,8	22	41	21,28	140	1	O	2,1	32	41	45,28
	2	O	1,3	22	60	33,28		2	O	2,9	38	60	69,76
	3	O	1,6	22	55	53,12		3	O	3,9	42	55	95,52
75▲	1	O	0,8	25	41	22,72	4▽	O	6,9	42	70	127,20	
	2	O	1,4	25	60	36,48	5▽	O	7,6	48	75	156,00	
	3	O	1,9	25	62	53,12	6▽	O	11,4	48	85	187,84	
80▲	1	O	1,0	28	41	24,16	150	1	O	2,4	32	43	53,12
	2	O	1,7	28	60	39,36		2	O	3,2	38	48	81,76
	3	O	2,1	28	55	56,00		3	O	4,3	42	60	104,64
	4▽	O	2,4	28	70	74,40		4▽	O	6,8	42	70	134,72
	5▽	O	2,7	28	80	89,28		5▽	O	8,4	48	75	163,68
85▲	1	O	1,1	30	41	24,16	6▽	O	12,1	48	85	200,48	
	2	O	1,7	30	60	41,12	160	1	x	2,5	38	43	57,76
	3	O	2,2	30	55	60,80		2	x	3,3	42	48	86,56
	4▽	O	2,7	30	70	77,44		3	x	4,6	48	60	109,28
	5▽	O	3,0	30	75	93,92		4▽	O	7,0	48	70	139,52
5▽	O	3,0	30	75	93,92	5▽		O	9,4	48	75	172,64	
90▲	1	O	1,2	32	41	25,76	6▽	O	12,9	55	85	213,12	
	2	O	1,8	38	60	44,32	170	1	x	2,9	42	43	66,88
	3	O	2,3	38	55	63,52		2	x	3,4	42	48	91,04
	4▽	O	3,1	38	70	81,76		3	x	4,9	42	60	119,68
	5▽	O	3,3	38	75	96,96		4▽	O	7,2	48	70	150,08
5▽	O	3,3	38	75	96,96	5▽		O	8,9	48	75	182,40	
95▲	1	O	1,3	35	41	27,20	6▽	O	13,1	48	85	225,76	
	2	O	2,0	38	60	45,76	180	1	x	3,1	38	43	68,16
	3	O	2,5	38	67	68,16		2	x	3,9	42	48	95,52
	4▽	O	2,9	38	70	84,64		3	x	5,3	48	60	130,40
	5▽	O	3,6	38	75	104,64		4▽	x	7,4	48	70	160,64
5▽	O	3,6	38	75	104,64	5▽		O	9,1	55	75	196,96	
100▲	1	O	1,3	32	41	32,00	6▽	O	10,8	60	85	236,64	
	2	O	2,1	38	60	49,92	190	1	x	3,2	42	43	75,68
	3	O	2,9	38	55	71,20		2	x	4,2	42	48	106,08
	4▽	O	3,8	38	70	91,04		3	x	5,5	42	60	137,76
	5▽	O	4,5	38	75	110,56		4▽	x	7,7	48	70	172,64
	6▽	O	5,2	38	124	145,60		5▽	O	9,2	50	75	207,68
6▽	O	5,2	38	124	145,60	6▽		O	12,0	55	85	252,80	
106▲	1	O	1,5	28	41	33,28	200	1	x	3,4	38	43	80,32
	2	O	2,0	28	60	53,12		2	x	4,5	42	48	112,16
	3	O	3,0	30	55	74,40		3	x	5,9	48	60	147,04
	4▽	O	4,3	30	70	95,52		4▽	x	8,0	50	60	182,40
	5▽	O	5,1	32	75	114,88		5▽	O	9,5	55	80	227,52
	6▽	O	6,0	32	124	151,68		6▽	O	12,2	60	90	280,00
112▲	1	O	1,5	32	41	33,28	212	1	x	3,8	42	43	89,28
	2	O	2,4	38	60	54,56		2	x	4,7	42	48	122,56
	3	O	3,1	38	55	77,44		3	x	6,2	48	60	157,44
	4▽	O	4,8	42	67	100,00		4▽	x	7,7	50	70	196,96
	5▽	O	5,6	42	75	124,32		5▽	x	10,3	50	80	236,64
	6▽	O	6,2	42	85	174,24		6▽	O	13,5	55	90	294,40
118▲	1	O	1,6	32	41	36,48	225	1	x	4,0	42	43	95,52
	2	O	2,4	38	60	59,04		2	x	5,4	42	48	130,40
	3	O	3,2	42	55	81,76		3	x	6,9	48	60	168,32
	4▽	O	5,2	42	70	104,64		4▽	x	8,6	55	70	213,12
	5▽	O	7,2	42	75	134,72		5▽	O	11,7	50	90	252,80
	6▽	O	6,6	42	85	169,44		6▽	O	14,8	55	90	325,12
125▲	1	O	1,7	32	41	39,36							
	2	O	2,6	38	60	62,24							
	3	O	3,3	42	55	83,68							
	4▽	O	4,7	42	70	107,68							
	5▽	O	8,6	42	75	137,76							
	6▽	O	8,0	48	85	175,68							

▲ nur für Profil 17 only for profile 17

▽ $d_d + 5,5$ mm

Anzahl der Rillen No. of grooves z	1	2	3	4	5	6
Kranzbreite Face width b_2 (mm)	25	44	63	86	105	124

- Vollscheibe Solid pulley
 - Bodenscheibe Plate pulley (mit oder ohne Spiegel with or without holes)
 - × Armscheibe Spoked pulley
- Nabenlage: einseitig bündig Hub position: one side flush
 Material: EN-GJL 200 – DIN EN 1561

Profil Profile SPB/17													
Richtdurchmesser Datum diameter d_d (mm)	Anzahl der Rillen No. of grooves	Ausführung Type	Gewicht Weight (\approx kg)	Fertigbohrung Finished bore d_{max} (mm)	Nabenslänge Hub length l (mm)	Fr. Stück zentriert each centered	Richtdurchmesser Datum diameter d_d (mm)	Anzahl der Rillen No. of grooves	Ausführung Type	Gewicht Weight (\approx kg)	Fertigbohrung Finished bore d_{max} (mm)	Nabenslänge Hub length l (mm)	Fr. Stück zentriert each centered
250	1	x	4,2	42	43	112,16	400	1▽	x	8,5	50	49	236,64
	2	x	6,1	48	55	151,68		2▽	x	10,0	55	55	299,84
	3	x	8,6	55	60	196,96		3▽	x	14,3	60	67	354,08
	4▽	x	9,8	60	70	247,52		4▽	x	18,5	65	80	491,20
	5▽	x	13,2	65	80	287,20		5▽	x	22,5	70	85	511,20
	6▽	x	17,0	65	90	346,72		6▽	x	28,0	75	90	561,76
280	1	x	5,7	48	49	132,00	450	1▽	x	9,9	50	55	254,72
	2	x	7,0	48	55	178,88		2▽	x	10,9	55	55	354,08
	3	x	9,7	55	60	224,00		3▽	x	15,1	60	67	419,04
	4▽	x	11,5	60	70	269,12		4▽	x	20,5	65	80	552,64
	5▽	x	15,5	65	80	325,12		5▽	x	26,0	70	80	661,12
	6▽	x	18,0	65	90	382,88		6▽	x	28,9	75	90	771,20
300	1	x	5,9	48	49	147,04	500	1▽	x	10,7	50	55	299,84
	2	x	7,5	48	55	196,96		2▽	x	13,7	60	59	392,00
	3	x	10,5	55	67	243,84		3▽	x	15,2	65	67	480,48
	4▽	x	12,4	60	80	294,40		4▽	x	21,3	70	80	639,36
	5▽	x	16,5	65	80	350,40		5▽	x	30,0	75	80	798,40
	6▽	x	18,3	70	90	410,08		6▽	x	33,8	80	90	1.060,16
315	1	x	6,4	48	49	159,20	560	2▽	x	15,0	60	55	516,64
	2	x	8,2	55	55	198,72		3▽	x	24,2	65	67	668,32
	3	x	12,9	55	67	263,68		4▽	x	26,0	70	80	825,44
	4▽	x	13,0	60	80	319,68		5▽	x	34,4	75	80	969,92
	5▽	x	17,6	65	80	368,48		6▽	x	39,0	80	90	1.119,84
	6▽	x	20,6	75	90	417,28							
355	1	x	7,0	48	49	187,84	630	2▽	x	20,2	60	80	680,96
	2	x	9,7	55	55	252,80		3▽	x	27,0	65	80	751,36
	3	x	13,4	55	67	303,36		4▽	x	30,8	75	86	1.016,80
	4▽	x	18,3	60	80	395,52		5▽	x	37,2	80	90	1.128,80
	5▽	x	18,8	65	75	419,04		6▽	x	44,0	90	100	1.255,36
	6▽	x	19,8	75	90	507,52							
▽ $d_d + 5,5$ mm													

Anzahl der Rillen No. of grooves z	1	2	3	4	5	6
Kranzbreite Face width b_2 (mm)	25	44	63	86	105	124

● Vollscheibe Solid pulley
 ○ Bodenscheibe Plate pulley (mit oder ohne Spiegel with or without holes)
 × Armscheibe Spoked pulley
 Nabenslage: einseitig bündig Hub position: one side flush
 Material: EN-GJL 200 – DIN EN 1561

Profil Profile SPC/22 (keine Lagerware *non stock items*)

Richtdurchmesser Datum diameter d_d (mm)	Anzahl der Rillen No. of grooves	Ausführung Type	Gewicht Weight (\approx kg)	Fertigbohrung Finished bore d_{max} (mm)	Nabenslänge Hub length l (mm)	Fr. Stück zentriert each centered	Richtdurchmesser Datum diameter d_d (mm)	Anzahl der Rillen No. of grooves	Ausführung Type	Gewicht Weight (\approx kg)	Fertigbohrung Finished bore d_{max} (mm)	Nabenslänge Hub length l (mm)	Fr. Stück zentriert each centered	
180	1	O	4,2	40	54	142,56	335	2	x	14,0	55	74	332,32	
	2	O	7,2	50	64	163,68		3	x	18,3	55	90	424,48	
	3	O	10,4	55	90	205,92		4	x	22,4	60	95	541,92	
	4	O	10,5	55	95	325,12		5	x	28,3	65	100	673,76	
	5	O	18,0	60	100	368,48		6	x	34,4	75	115	791,04	
	6	O	23,6	65	115	419,04								
200	1	O	4,8	40	54	160,64	355	2	x	15,2	60	74	321,44	
	2	O	7,8	50	64	180,32		3	x	19,2	70	90	431,68	
	3	O	8,8	55	90	227,52		4	x	25,8	70	95	547,20	
	4	O	11,2	60	95	377,44		5	x	32,0	75	100	648,48	
	5	O	15,4	65	100	426,24		6	x	36,2	75	115	751,36	
	6	O	27,0	70	125	475,04								
225	1	x	5,5	48	54	182,40	400	3	x	20,6	70	90	496,64	
	2	x	7,8	52	64	242,08		4	x	28,0	70	105	545,44	
	3	x	10,6	52	90	251,04		5	x	32,0	75	100	832,64	
	4	x	13,1	55	95	429,92								
	5	x	16,7	60	100	449,76		450	2	x	21,1	70	80	419,04
	6	x	35,0	60	115	509,28			3	x	26,3	75	90	594,24
						4	x		31,1	75	105	661,12		
						5	x		42,2	80	110	895,84		
						6	x		48,5	80	120	998,88		
250	1	x	7,3	52	54	198,72	500	3	x	28,4	75	90	671,84	
	2	x	8,8	52	64	261,92		4	x	34,1	75	105	760,48	
	3	x	11,0	65	90	303,36		5	x	48,2	80	110	1.009,60	
	4	x	15,3	70	95	465,92		6	x	52,5	80	120	1.128,80	
	5	x	19,0	75	100	476,80		560	3	x	31,1	75	90	789,28
	6	x	23,7	60	115	527,36			4	x	39,0	75	105	904,96
						5	x		54,1	80	110	1.206,56		
						6	x		61,5	85	120	1.551,52		
						630	3		x	38,5	80	90	932,00	
							4		x	48,1	80	105	1.226,40	
							5	x	62,2	85	110	1.403,36		
							6	x	73,2	85	120	1.968,80		

Anzahl der Rillen No. of grooves z	1	2	3	4	5	6
Kranzbreite Face width b_2 (mm)	38	64	90	116	142	168

● Vollscheibe *Solid pulley*
 O Bodenscheibe *Plate pulley*
 (mit oder ohne Spiegel *with or without holes*)
 × Armscheibe *Spoked pulley*
 Nabenlage: einseitig bündig *Hub position: one side flush*
 Material: EN-GJL 200 – DIN EN 1561



Regelscheiben für zylindrische Bohrung Variable speed pulleys for plain boring Material: GG

Bezeichnung Designation	DA (mm)	D (mm)	Fertigbohrung Finished bore d _{max} (mm)	B (mm)	Profil Profile	d _{d min} (mm)	d _{d max} (mm)	Regel- faktor Variance factor	Gewicht Weight (≈ kg)	Fr. Stück zentriert each centered	
R 083-1	83	40	26	48	SPZ Z/10	63 57	79 77	1,25 1,35	0,90	auf Anfrage on request	
R 093-1	93	45	28	48	SPZ SPA Z/10 A/13	67 66 61 60	89 87 87 85	1,33 1,32 1,43 1,42	1,03		
R 108-1	108	50	28	48	SPZ SPA Z/10 A/13	79 81 73 75	94 102 93 100	1,19 1,26 1,27 1,33	1,65		
R 121-1	121	55	28	48	SPZ SPA Z/10 A/13	92 94 86 88	107 115 106 113	1,16 1,22 1,23 1,28	1,75		
R 138-1	138	55	38	48	SPZ SPA SPB Z/10 A/13 B/17	109 111 116 103 105 109	124 132 131 123 130 128	1,14 1,19 1,13 1,19 1,24 1,17	2,60		
R 160-1	160	80	52	48	SPZ SPA SPB Z/10 A/13 B/17	119 121 126 113 115 119	134 143 153 133 141 150	1,13 1,18 1,21 1,18 1,23 1,26	4,50		
R 180-1	180	80	52	48	SPA SPB A/13 B/17	141 146 135 139	163 173 161 170	1,16 1,18 1,19 1,22	5,40		



Regelscheiben für zylindrische Bohrung Variable speed pulleys for plain boring Material: GG

Bezeichnung Designation	DA (mm)	D (mm)	Fertigbohrung Finished bore d _{max} (mm)	B (mm)	Profil Profile	d _{d min} (mm)	d _{d max} (mm)	Regel- faktor Variance factor	Gewicht Weight (≈ kg)	Fr. Stück zentriert each centered
R 083-2	83	40	26	76	SPZ Z/10	63 57	79 77	1,25 1,35	1,50	auf Anfrage on request
R 093-2	93	45	28	76	SPZ SPA Z/10 A/13	67 66 61 60	89 87 87 85	1,33 1,32 1,43 1,42	1,75	
R 108-2	108	50	28	76	SPZ SPA Z/10 A/13	79 81 73 75	94 102 93 100	1,19 1,26 1,27 1,33	2,15	
R 121-2	121	55	28	76	SPZ SPA Z/10 A/13	92 94 86 88	107 115 106 113	1,16 1,22 1,23 1,28	2,70	
R 138-2	138	55	38	76	SPZ SPA SPB Z/10 A/13 B/17	109 111 116 103 105 109	124 132 131 123 130 128	1,14 1,19 1,13 1,19 1,24 1,17	4,50	
R 160-2	160	80	52	90	SPZ SPA SPB Z/10 A/13 B/17	119 121 126 113 115 119	134 143 153 133 141 150	1,13 1,18 1,21 1,18 1,23 1,26	7,50	
R 180-2	180	80	52	90	SPA SPB A/13 B/17	141 146 135 139	163 173 161 170	1,16 1,18 1,19 1,22	9,20	

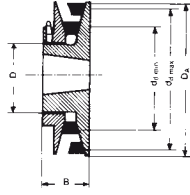

Regelscheiben für Taper-Buchsen <i>Variable speed pulleys for taper bushes</i>											Material: GG
Bezeichnung <i>Designation</i>	DA (mm)	D (mm)	Fertigbohrung <i>Finished bore</i> d _{max} (mm)	B (mm)	Profil <i>Profile</i>	d _{d min} (mm)	d _{d max} (mm)	Regel- faktor <i>Variance</i> factor	Gewicht ohne Buchse <i>Weight</i> without bushing (≈ kg)	Taper- Buchse <i>Taper</i> bushing	Fr. Stück ohne Buchse each without bushing
TB-R 092-1	92	46	25	31	SPZ Z/10	60 55	89 88	1,48 1,60	0,85	1008	auf Anfrage on request
TB-R 108-1	108	50	28	35	SPZ SPA Z/10 A/13 B/17	75 76 68 70 87	93 102 92 100 97	1,24 1,34 1,35 1,43 1,11	1,20	1108	
TB-R 120-1	120	55	28	35	SPZ SPA Z/10 A/13 B/17	87 88 80 82 98	105 114 104 112 108	1,20 1,29 1,30 1,36 1,10	1,50	1108	
TB-R 138-1	138	65	32	38	SPZ SPA Z/10 A/13 B/17	105 106 98 100 116	123 132 122 130 126	1,17 1,24 1,24 1,30 1,09	2,20	1215	
TB-R 159-1	159	75	42	39	SPZ SPA Z/10 A/13 B/17	126 128 122 128 125	144 154 152 152 148	1,14 1,20 1,24 1,18 1,18	3,50	1615	
TB-R 180-1	180	75	42	45	SPZ SPA SPB Z/10 A/13 B/17	133 134 137 128 128 132	151 160 173 151 158 170	1,14 1,19 1,26 1,17 1,23 1,29	4,20	1615	

Taper-Buchse <i>Taper bushing</i>	1008	1108	1215	1615
Bohrung d ₂ (mm) von ... bis ... <i>Bore d₂ (mm) from ... to ...</i>	10-25	10-28	11-32	14-42
Fr./Stück <i>each</i>	12,48	12,96	20,16	23,04

GG = Grauguss *Cast iron*
Fertigungstechnische Änderungen vorbehalten. *We reserve the right to make technical changes.*
Bohrungsdurchmesser d₂ siehe Seite 3.
Bore diameters d₂ see page 3.

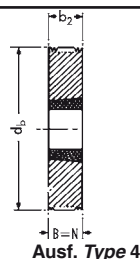
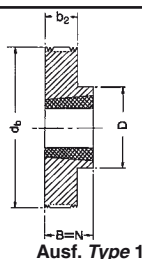

Bezeichnung Designation	Anzahl der Rillen No. of ribs	Aus- führung Type	Material	d _b (mm)	b ₂ (mm)	B (mm)	N (mm)	D (mm)	Taper- Buchse Taper bushing	Fr. Stück ohne Buchse each without bushing
TB 4 PJ 47,5	4	1	GG	47,5	13	23	23	47,5	1008	96,96
TB 4 PJ 52,5	4	1	GG	52,5	13	23	23	47,5	1008	97,92
TB 4 PJ 57,5	4	1	GG	57,5	13	23	23	54,0	1108	98,72
TB 4 PJ 62,5	4	1	GG	62,5	13	23	23	54,0	1108	99,36
TB 4 PJ 67,5	4	1	GG	67,5	13	23	23	54,0	1108	100,16
TB 4 PJ 72,5	4	1	GG	72,5	13	23	23	54,0	1108	101,76
TB 4 PJ 77,5	4	1	GG	77,5	13	26	26	70,0	1210	103,36
TB 4 PJ 82,5	4	1	GG	82,5	13	26	26	78,0	1210	104,64
TB 4 PJ 87,5	4	1	GG	87,5	13	26	26	78,0	1210	105,92
TB 4 PJ 92,5	4	1	GG	92,5	13	26	26	78,0	1210	108,32
TB 4 PJ 97,5	4	1	GG	97,5	13	26	26	78,0	1210	109,28
TB 4 PJ 102,5	4	1	GG	102,5	13	26	26	85,0	1610	120,00
TB 4 PJ 107,5	4	1	GG	107,5	13	26	26	85,0	1610	138,24
TB 4 PJ 112,5	4	1	GG	112,5	13	26	26	85,0	1610	140,80
TB 4 PJ 117,5	4	1	GG	117,5	13	26	26	85,0	1610	141,60
TB 4 PJ 122,5	4	1	GG	122,5	13	26	26	85,0	1610	144,16
TB 4 PJ 127,5	4	1	GG	127,5	13	26	26	85,0	1610	144,96
TB 4 PJ 137,5	4	1	GG	137,5	13	26	26	85,0	1610	149,76
TB 4 PJ 152,5	4	1	GG	152,5	13	26	26	85,0	1610	156,80
TB 4 PJ 162,5	4	1	GG	162,5	13	26	26	85,0	1610	161,28
TB 4 PJ 172,5	4	1	GG	172,5	13	26	26	85,0	1610	167,20
TB 4 PJ 182,5	4	1	GG	182,5	13	26	26	85,0	1610	172,80
TB 4 PJ 192,5	4	1	GG	192,5	13	26	26	85,0	1610	177,28
TB 4 PJ 202,5	4	1	GG	202,5	13	33	33	100,0	2012	200,32
TB 4 PJ 222,5	4	1	GG	222,5	13	33	33	100,0	2012	210,88
TB 8 PJ 47,5	8	4	GG	47,5	23	23	23	—	1008	98,88
TB 8 PJ 52,5	8	4	GG	52,5	23	23	23	—	1008	99,68
TB 8 PJ 57,5	8	4	GG	57,5	23	23	23	—	1108	100,32
TB 8 PJ 62,5	8	4	GG	62,5	23	23	23	—	1108	101,76
TB 8 PJ 67,5	8	4	GG	67,5	23	23	23	—	1108	102,24
TB 8 PJ 72,5	8	4	GG	72,5	23	23	23	—	1108	103,84
TB 8 PJ 77,5	8	1	GG	77,5	23	26	26	70,0	1210	105,60
TB 8 PJ 82,5	8	1	GG	82,5	23	26	26	78,0	1210	107,04
TB 8 PJ 87,5	8	1	GG	87,5	23	26	26	78,0	1210	108,16
TB 8 PJ 92,5	8	1	GG	92,5	23	26	26	78,0	1210	110,72
TB 8 PJ 97,5	8	1	GG	97,5	23	26	26	78,0	1210	111,84
TB 8 PJ 102,5	8	1	GG	102,5	23	26	26	85,0	1610	122,08
TB 8 PJ 107,5	8	1	GG	107,5	23	26	26	85,0	1610	141,60
TB 8 PJ 112,5	8	1	GG	112,5	23	26	26	85,0	1610	143,04
TB 8 PJ 117,5	8	1	GG	117,5	23	26	26	85,0	1610	144,96
TB 8 PJ 122,5	8	1	GG	122,5	23	26	26	85,0	1610	146,40
TB 8 PJ 127,5	8	1	GG	127,5	23	26	26	85,0	1610	148,96
TB 8 PJ 137,5	8	1	GG	137,5	23	26	26	85,0	1610	153,12
TB 8 PJ 152,5	8	1	GG	152,5	23	26	26	85,0	1610	160,16
TB 8 PJ 162,5	8	1	GG	162,5	23	26	26	85,0	1610	168,32
TB 8 PJ 172,5	8	1	GG	172,5	23	26	26	85,0	1610	175,36
TB 8 PJ 182,5	8	1	GG	182,5	23	26	26	85,0	1610	180,80
TB 8 PJ 192,5	8	1	GG	192,5	23	26	26	85,0	1610	187,84
TB 8 PJ 202,5	8	1	GG	202,5	23	33	33	100,0	2012	209,12
TB 8 PJ 222,5	8	1	GG	222,5	23	33	33	100,0	2012	221,60

Taper-Buchse Taper bushing	1008	1108	1210	1610	2012
Bohrung d ₂ (mm) von ... bis ... Bore d ₂ (mm) from ... to ...	10-25	10-28	11-32	14-42	14-50
Fr./Stück each	12,48	12,96	18,40	20,80	24,64

GG = Grauguss Cast iron
 Weitere Abmessungen auf Anfrage.
 Further sizes on request.
 Fertigungstechnische Änderungen vorbehalten.
 We reserve the right to make technical changes.
 Bohrungsdurchmesser d₂ siehe Seite 3.
 Bore diameters d₂ see page 3.

optibelt RBS Keilrippenscheiben für Taper-Buchsen, Profil PJ
Ribbed Belt Pulleys for Taper Bushings, Profile PJ

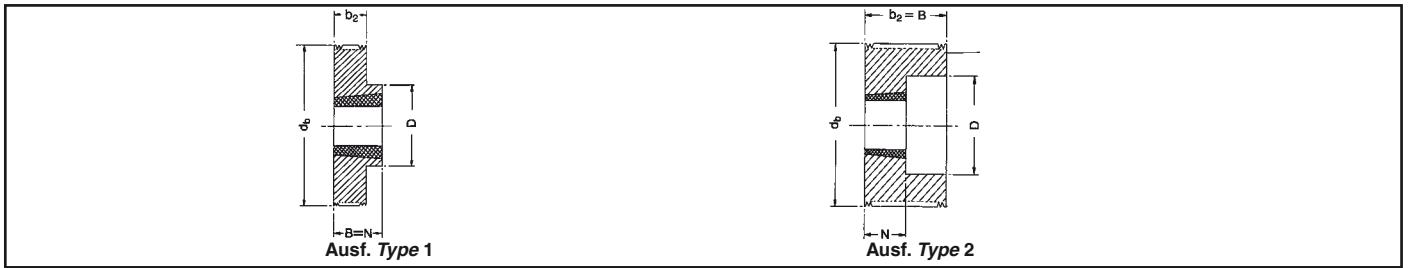

Bezeichnung Designation	Anzahl der Rillen No. of ribs	Aus- führung Type	Material	d _b (mm)	b ₂ (mm)	B (mm)	N (mm)	D (mm)	Taper- Buchse Taper bushing	Fr. Stück ohne Buchse each without bushing
TB 12 PJ 62,5	12	2	GG	62,5	32	32	23	50,0	1108	103,52
TB 12 PJ 67,5	12	2	GG	67,5	32	32	23	50,0	1108	104,32
TB 12 PJ 72,5	12	2	GG	72,5	32	32	23	50,0	1108	105,92
TB 12 PJ 77,5	12	2	GG	77,5	32	32	26	62,0	1210	107,68
TB 12 PJ 82,5	12	2	GG	82,5	32	32	26	62,0	1210	109,12
TB 12 PJ 87,5	12	2	GG	87,5	32	32	26	70,0	1610	120,00
TB 12 PJ 92,5	12	2	GG	92,5	32	32	26	70,0	1610	122,08
TB 12 PJ 97,5	12	2	GG	97,5	32	32	26	70,0	1610	123,36
TB 12 PJ 102,5	12	2	GG	102,5	32	32	26	70,0	1610	125,60
TB 12 PJ 107,5	12	2	GG	107,5	32	32	26	70,0	1610	144,16
TB 12 PJ 112,5	12	2	GG	112,5	32	32	26	70,0	1610	146,40
TB 12 PJ 117,5	12	2	GG	117,5	32	32	26	70,0	1610	148,96
TB 12 PJ 122,5	12	2	GG	122,5	32	32	26	70,0	1610	149,76
TB 12 PJ 127,5	12	1	GG	127,5	32	32	33	100,0	2012	167,20
TB 12 PJ 137,5	12	1	GG	137,5	32	32	33	100,0	2012	172,00
TB 12 PJ 152,5	12	1	GG	152,5	32	32	33	100,0	2012	179,04
TB 12 PJ 162,5	12	1	GG	162,5	32	32	33	100,0	2012	187,84
TB 12 PJ 172,5	12	1	GG	172,5	32	32	33	100,0	2012	195,04
TB 12 PJ 182,5	12	1	GG	182,5	32	46	46	110,0	2517	214,40
TB 12 PJ 192,5	12	1	GG	192,5	32	46	46	110,0	2517	221,60
TB 12 PJ 202,5	12	1	GG	202,5	32	46	46	110,0	2517	230,40
TB 12 PJ 222,5	12	1	GG	222,5	32	46	46	110,0	2517	244,64
TB 16 PJ 62,5	16	2	GG	62,5	41	41	23	50,0	1108	106,40
TB 16 PJ 67,5	16	2	GG	67,5	41	41	23	50,0	1108	107,36
TB 16 PJ 72,5	16	2	GG	72,5	41	41	26	62,0	1210	108,96
TB 16 PJ 77,5	16	2	GG	77,5	41	41	26	62,0	1210	110,40
TB 16 PJ 82,5	16	2	GG	82,5	41	41	26	62,0	1210	111,68
TB 16 PJ 87,5	16	2	GG	87,5	41	41	26	70,0	1610	122,08
TB 16 PJ 92,5	16	2	GG	92,5	41	41	26	70,0	1610	124,64
TB 16 PJ 97,5	16	2	GG	97,5	41	41	26	70,0	1610	125,60
TB 16 PJ 102,5	16	2	GG	102,5	41	41	26	70,0	1610	128,00
TB 16 PJ 107,5	16	2	GG	107,5	41	41	26	70,0	1610	162,72
TB 16 PJ 112,5	16	2	GG	112,5	41	41	33	85,0	2012	164,80
TB 16 PJ 117,5	16	2	GG	117,5	41	41	33	85,0	2012	165,92
TB 16 PJ 122,5	16	2	GG	122,5	41	41	33	85,0	2012	168,32
TB 16 PJ 127,5	16	2	GG	127,5	41	41	33	85,0	2012	170,56
TB 16 PJ 137,5	16	2	GG	137,5	41	41	33	85,0	2012	175,36
TB 16 PJ 152,5	16	2	GG	152,5	41	41	33	85,0	2012	182,56
TB 16 PJ 162,5	16	2	GG	162,5	41	41	33	85,0	2012	196,80
TB 16 PJ 172,5	16	2	GG	172,5	41	41	33	85,0	2012	203,84
TB 16 PJ 182,5	16	1	GG	182,5	41	46	46	110,0	2517	225,12
TB 16 PJ 192,5	16	1	GG	192,5	41	46	46	110,0	2517	232,16
TB 16 PJ 202,5	16	1	GG	202,5	41	46	46	110,0	2517	239,36
TB 16 PJ 222,5	16	1	GG	222,5	41	46	46	110,0	2517	255,20

Taper-Buchse Taper bushing	1108	1210	1610	2012	2517
Bohrung d ₂ (mm) von ... bis ... Bore d ₂ (mm) from ... to ...	10-28	11-32	14-42	14-50	16-60
Fr./Stück each	12,96	18,40	20,80	24,64	37,60

GG = Grauguss Cast iron
 Weitere Abmessungen auf Anfrage.
 Further sizes on request.
 Fertigungstechnische Änderungen vorbehalten.
 We reserve the right to make technical changes.
 Bohrungsdurchmesser d₂ siehe Seite 3.
 Bore diameters d₂ see page 3.

optibelt RBS Keilrippenscheiben für Taper-Buchsen, Profil PL (keine Lagerware)
Ribbed Belt Pulleys for Taper Bushings, Profile PL (non stock items)

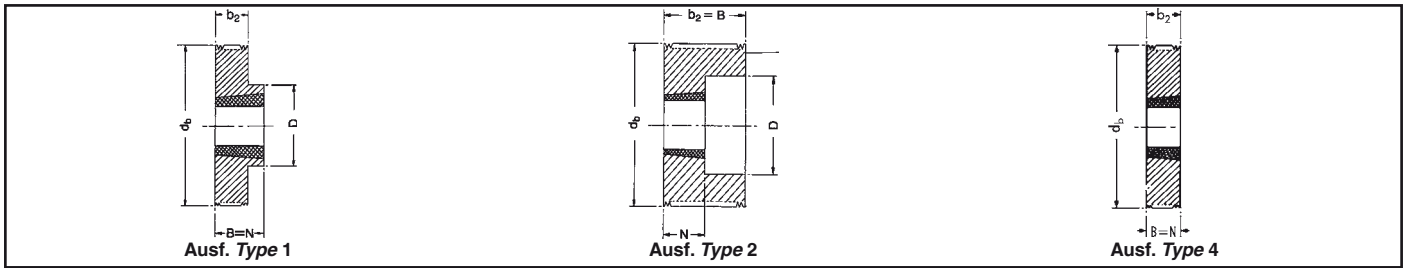

Bezeichnung Designation	Anzahl der Rillen No. of ribs	Aus- führung Type	Material	d _b (mm)	b ₂ (mm)	B (mm)	N (mm)	D (mm)	Taper- Buchse Taper bushing	Fr. Stück ohne Buchse each without bushing
TB 6 PL 78	6	2	GG	78	33	33	26	62,0	1210	123,36
TB 6 PL 83	6	2	GG	83	33	33	26	62,0	1210	134,88
TB 6 PL 88	6	2	GG	88	33	33	26	70,0	1610	136,96
TB 6 PL 93	6	2	GG	93	33	33	26	70,0	1610	139,68
TB 6 PL 98	6	2	GG	98	33	33	26	70,0	1610	140,80
TB 6 PL 103	6	2	GG	103	33	33	26	70,0	1610	164,80
TB 6 PL 108	6	2	GG	108	33	33	26	70,0	1610	167,20
TB 6 PL 113	6	2	GG	113	33	33	26	70,0	1610	168,32
TB 6 PL 118	6	2	GG	118	33	33	26	70,0	1610	170,56
TB 6 PL 123	6	4	GG	123	33	33	33	—	2012	189,60
TB 6 PL 133	6	4	GG	133	33	33	33	—	2012	195,04
TB 6 PL 148	6	4	GG	148	33	33	33	—	2012	203,84
TB 6 PL 158	6	4	GG	158	33	33	33	—	2012	212,64
TB 6 PL 168	6	4	GG	168	33	33	33	—	2012	221,60
TB 6 PL 178	6	1	GG	178	33	46	46	110,0	2517	244,64
TB 6 PL 188	6	1	GG	188	33	46	46	110,0	2517	249,92
TB 6 PL 198	6	1	GG	198	33	46	46	110,0	2517	258,72
TB 6 PL 218	6	1	GG	218	33	46	46	110,0	2517	278,24
TB 6 PL 238	6	1	GG	238	33	46	46	110,0	2517	545,92
TB 6 PL 258	6	1	GG	258	33	46	46	110,0	2517	570,72
TB 6 PL 278	6	1	GG	278	33	46	46	110,0	2517	595,52
TB 6 PL 298	6	1	GG	298	33	46	46	110,0	2517	623,84
TB 6 PL 318	6	1	GG	318	33	46	46	110,0	2517	692,96
TB 6 PL 348	6	1	GG	348	33	46	46	110,0	2517	744,48
TB 6 PL 388	6	1	GG	388	33	46	46	110,0	2517	831,20
TB 8 PL 78	8	2	GG	78	42	42	26	62,0	1210	130,24
TB 8 PL 83	8	2	GG	83	42	42	26	62,0	1210	131,36
TB 8 PL 88	8	2	GG	88	42	42	26	70,0	1610	144,16
TB 8 PL 93	8	2	GG	93	42	42	26	70,0	1610	146,40
TB 8 PL 98	8	2	GG	98	42	42	26	70,0	1610	147,68
TB 8 PL 103	8	2	GG	103	42	42	33	85,0	2012	187,84
TB 8 PL 108	8	2	GG	108	42	42	33	85,0	2012	191,36
TB 8 PL 113	8	2	GG	113	42	42	33	85,0	2012	193,28
TB 8 PL 118	8	2	GG	118	42	42	33	85,0	2012	196,80
TB 8 PL 123	8	2	GG	123	42	42	33	85,0	2012	198,56
TB 8 PL 133	8	2	GG	133	42	42	33	85,0	2012	203,84
TB 8 PL 148	8	2	GG	148	42	42	33	85,0	2012	212,64
TB 8 PL 158	8	2	GG	158	42	42	33	85,0	2012	225,12
TB 8 PL 168	8	2	GG	168	42	42	33	85,0	2012	233,92
TB 8 PL 178	8	1	GG	178	42	46	46	110,0	2517	256,96
TB 8 PL 188	8	1	GG	188	42	46	46	110,0	2517	264,16
TB 8 PL 198	8	1	GG	198	42	46	46	110,0	2517	276,48
TB 8 PL 218	8	1	GG	218	42	46	46	110,0	2517	292,48
TB 8 PL 238	8	1	GG	238	42	46	46	110,0	2517	583,20
TB 8 PL 258	8	1	GG	258	42	46	46	110,0	2517	608,00
TB 8 PL 278	8	1	GG	278	42	46	46	110,0	2517	634,56
TB 8 PL 298	8	1	GG	298	42	46	46	110,0	2517	668,16
TB 8 PL 318	8	1	GG	318	42	46	46	110,0	2517	737,28
TB 8 PL 348	8	1	GG	348	42	46	46	110,0	2517	797,60
TB 8 PL 388	8	1	GG	388	42	46	46	110,0	2517	893,28

Taper-Buchse Taper bushing	1210	1610	2012	2517
Bohrung d ₂ (mm) von ... bis ... Bore d ₂ (mm) from ... to ...	11-32	14-42	14-50	16-60
Fr./Stück each	18,40	20,80	24,64	37,60

GG = Grauguss Cast iron
 Weitere Abmessungen auf Anfrage.
 Further sizes on request.
 Fertigungstechnische Änderungen vorbehalten.
 We reserve the right to make technical changes.
 Bohrungsdurchmesser d₂ siehe Seite 3.
 Bore diameters d₂ see page 3.

optibelt RBS Keilrippenscheiben für Taper-Buchsen, Profil PL (keine Lagerware)
Ribbed Belt Pulleys for Taper Bushings, Profile PL (non stock items)

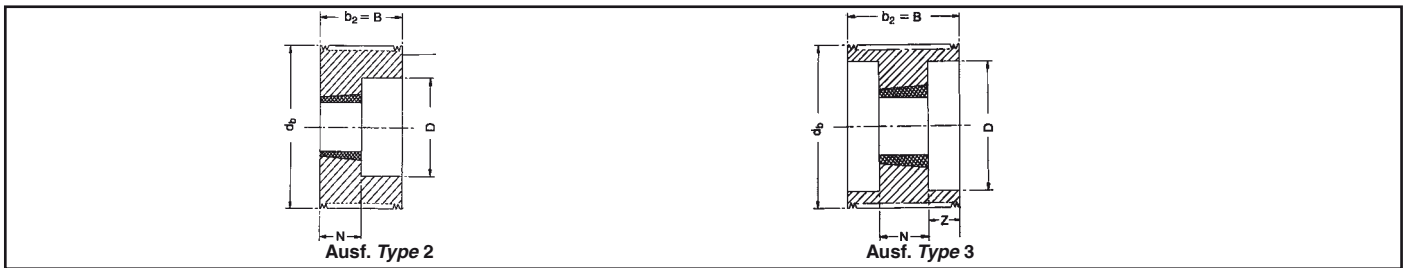

Bezeichnung Designation	Anzahl der Rillen No. of ribs	Aus- führung Type	Material	d _b (mm)	b ₂ (mm)	B (mm)	N (mm)	D (mm)	Taper- Buchse Taper bushing	Fr. Stück ohne Buchse each without bushing
TB 10 PL 88	10	3	GG	88	53	53	26	70,0	1610	189,60
TB 10 PL 93	10	3	GG	93	53	53	26	70,0	1610	191,36
TB 10 PL 98	10	3	GG	98	53	53	26	70,0	1610	195,04
TB 10 PL 103	10	2	GG	103	53	53	33	85,0	2012	246,40
TB 10 PL 108	10	2	GG	108	53	53	33	85,0	2012	249,92
TB 10 PL 113	10	2	GG	113	53	53	33	85,0	2012	253,44
TB 10 PL 118	10	2	GG	118	53	53	33	85,0	2012	256,96
TB 10 PL 123	10	2	GG	123	53	53	33	85,0	2012	260,48
TB 10 PL 133	10	2	GG	133	53	53	33	85,0	2012	265,92
TB 10 PL 148	10	2	GG	148	53	53	33	85,0	2012	281,76
TB 10 PL 158	10	2	GG	158	53	53	33	85,0	2012	294,24
TB 10 PL 168	10	2	GG	168	53	53	33	85,0	2012	310,24
TB 10 PL 178	10	2	GG	178	53	53	46	105,0	2517	338,56
TB 10 PL 188	10	2	GG	188	53	53	46	105,0	2517	347,36
TB 10 PL 198	10	2	GG	198	53	53	46	105,0	2517	359,84
TB 10 PL 218	10	2	GG	218	53	53	46	105,0	2517	386,40
TB 10 PL 238	10	2	GG	238	53	53	46	105,0	2517	618,56
TB 10 PL 258	10	2	GG	258	53	53	46	105,0	2517	648,64
TB 10 PL 278	10	2	GG	278	53	53	46	105,0	2517	677,12
TB 10 PL 298	10	2	GG	298	53	53	46	105,0	2517	712,48
TB 10 PL 318	10	2	GG	318	53	53	46	105,0	2517	790,56
TB 10 PL 348	10	2	GG	348	53	53	46	105,0	2517	852,48
TB 10 PL 388	10	2	GG	388	53	53	46	105,0	2517	953,60
TB 12 PL 88	12	3	GG	88	62	62	26	70,0	1610	195,04
TB 12 PL 93	12	3	GG	93	62	62	26	70,0	1610	196,80
TB 12 PL 98	12	3	GG	98	62	62	26	70,0	1610	200,32
TB 12 PL 103	12	3	GG	103	62	62	33	85,0	2012	253,44
TB 12 PL 108	12	3	GG	108	62	62	33	85,0	2012	255,20
TB 12 PL 113	12	3	GG	113	62	62	33	85,0	2012	258,72
TB 12 PL 118	12	3	GG	118	62	62	33	85,0	2012	262,24
TB 12 PL 123	12	3	GG	123	62	62	33	85,0	2012	265,92
TB 12 PL 133	12	3	GG	133	62	62	33	85,0	2012	276,48
TB 12 PL 148	12	2	GG	148	62	62	46	105,0	2517	310,24
TB 12 PL 158	12	2	GG	158	62	62	46	105,0	2517	322,56
TB 12 PL 168	12	2	GG	168	62	62	46	105,0	2517	336,80
TB 12 PL 178	12	2	GG	178	62	62	46	105,0	2517	345,60
TB 12 PL 188	12	2	GG	188	62	62	46	105,0	2517	358,08
TB 12 PL 198	12	2	GG	198	62	62	46	105,0	2517	370,40
TB 12 PL 218	12	2	GG	218	62	62	46	105,0	2517	395,20
TB 12 PL 238	12	2	GG	238	62	62	52	130,0	3020	838,40
TB 12 PL 258	12	2	GG	258	62	62	52	130,0	3020	1.035,04
TB 12 PL 278	12	2	GG	278	62	62	52	130,0	3020	1.067,04
TB 12 PL 298	12	2	GG	298	62	62	52	130,0	3020	1.104,16
TB 12 PL 318	12	2	GG	318	62	62	52	130,0	3020	1.182,24
TB 12 PL 348	12	2	GG	348	62	62	52	130,0	3020	1.247,84
TB 12 PL 388	12	2	GG	388	62	62	52	130,0	3020	1.350,56

Taper-Buchse Taper bushing	1610	2012	2517	3020
Bohrung d ₂ (mm) von ... bis ... Bore d ₂ (mm) from ... to ...	14-42	14-50	16-60	25-75
Fr./Stück each	20,80	24,64	37,60	50,24

GG = Grauguss Cast iron
 Weitere Abmessungen auf Anfrage.
 Further sizes on request.
 Fertigungstechnische Änderungen vorbehalten.
 We reserve the right to make technical changes.
 Bohrungsdurchmesser d₂ siehe Seite 3.
 Bore diameters d₂ see page 3.

optibelt **RBS** Keilrippenscheiben für Taper-Buchsen, Profil PL (keine Lagerware) Ribbed Belt Pulleys for Taper Bushings, Profile PL (non stock items)

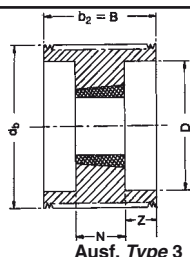

Ausf. Type 3

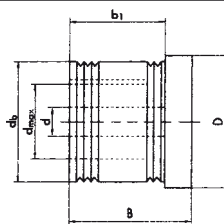

Ausf. Type VB (für zyl. Bohrung for plain boring)

Bezeichnung Designation	Anzahl der Rillen No. of ribs	Aus- führung Type	Material	d _b (mm)	b ₂ (mm)	B (mm)	N (mm)	D (mm)	Taper- Buchse Taper bushing	Fr. Stück ohne Buchse each without bushing
TB 16 PL 103	16	3	GG	103	80	80	33	85,0	2012	260,48
TB 16 PL 108	16	3	GG	108	80	80	33	85,0	2012	264,16
TB 16 PL 113	16	3	GG	113	80	80	33	85,0	2012	265,92
TB 16 PL 118	16	3	GG	118	80	80	33	85,0	2012	274,72
TB 16 PL 123	16	3	GG	123	80	80	33	85,0	2012	278,24
TB 16 PL 133	16	3	GG	133	80	80	33	85,0	2012	283,52
TB 16 PL 148	16	3	GG	148	80	80	46	105,0	2517	319,04
TB 16 PL 158	16	3	GG	158	80	80	46	105,0	2517	342,08
TB 16 PL 168	16	3	GG	168	80	80	46	105,0	2517	356,32
TB 16 PL 178	16	3	GG	178	80	80	46	105,0	2517	366,88
TB 16 PL 188	16	3	GG	188	80	80	46	105,0	2517	379,36
TB 16 PL 198	16	3	GG	198	80	80	46	105,0	2517	391,68
TB 16 PL 218	16	3	GG	218	80	80	46	105,0	2517	420,00
TB 16 PL 238	16	3	GG	238	80	80	52	130,0	3020	870,24
TB 16 PL 258	16	3	GG	258	80	80	52	130,0	3020	895,04
TB 16 PL 278	16	3	GG	278	80	80	52	130,0	3020	921,60
TB 16 PL 298	16	3	GG	298	80	80	52	130,0	3020	955,36
TB 16 PL 318	16	3	GG	318	80	80	52	130,0	3020	1.024,48
TB 16 PL 348	16	3	GG	348	80	80	52	130,0	3020	1.082,88
TB 16 PL 388	16	3	GG	388	80	80	52	130,0	3020	1.175,04

Taper-Buchse Taper bushing	2012	2517	3020
Bohrung d ₂ (mm) von ... bis ... Bore d ₂ (mm) from ... to ...	14-50	16-60	25-75
Fr./Stück each	24,64	37,60	50,24

Bohrungsdurchmesser d₂ siehe Seite 3.
Bore diameters d₂ see page 3.

optibelt **RBS** Keilrippenscheiben für zylindrische Bohrung, Profil PJ Ribbed Belt Pulleys for Plain Boring, Profile PJ

Bezeichnung Designation	Anzahl der Rillen No. of ribs	Aus- führung Type	Material	d _b (mm)	b ₁ (mm)	B (mm)	D (mm)	Vorbohrung Pilot bore d (mm)	Fertig- bohrung Finished bore d _{max} (mm)	Gewicht Weight (≈ kg)	Fr. Stück each
4 PJ 22,5	4	VB	GG	22,5	13	20	25	8	12,0	0,045	37,92
4 PJ 27,5	4	VB	GG	27,5	13	20	30	8	14,0	0,070	40,48
4 PJ 32,5	4	VB	GG	32,5	13	20	35	8	18,0	0,100	42,56
4 PJ 37,5	4	VB	GG	37,5	13	20	40	8	20,0	0,135	44,96
4 PJ 42,5	4	VB	GG	42,5	13	20	45	8	22,0	0,180	49,76
8 PJ 22,5	8	VB	GG	22,5	23	30	25	8	12,0	0,063	40,48
8 PJ 27,5	8	VB	GG	27,5	23	30	30	8	14,0	0,100	42,56
8 PJ 32,5	8	VB	GG	32,5	23	30	35	8	18,0	0,150	45,92
8 PJ 37,5	8	VB	GG	37,5	23	30	40	8	20,0	0,200	50,72
8 PJ 42,5	8	VB	GG	42,5	23	30	45	8	22,0	0,265	55,20
12 PJ 22,5	12	VB	GG	22,5	32	40	25	8	12,0	0,086	44,00
12 PJ 27,5	12	VB	GG	27,5	32	40	30	8	14,0	0,140	47,36
12 PJ 32,5	12	VB	GG	32,5	32	40	35	8	18,0	0,200	50,72
12 PJ 37,5	12	VB	GG	37,5	32	40	40	8	20,0	0,280	54,08
12 PJ 42,5	12	VB	GG	42,5	32	40	45	8	22,0	0,360	60,00

GG = Grauguss Cast iron

Weitere Abmessungen auf Anfrage. Further sizes on request.

Fertigungstechnische Änderungen vorbehalten. We reserve the right to make technical changes.

optibelt F5 Flachriemenscheiben für Taper-Buchsen (keine Lagerware)
Flat Belt Pulleys for Taper Bushings (non stock items)

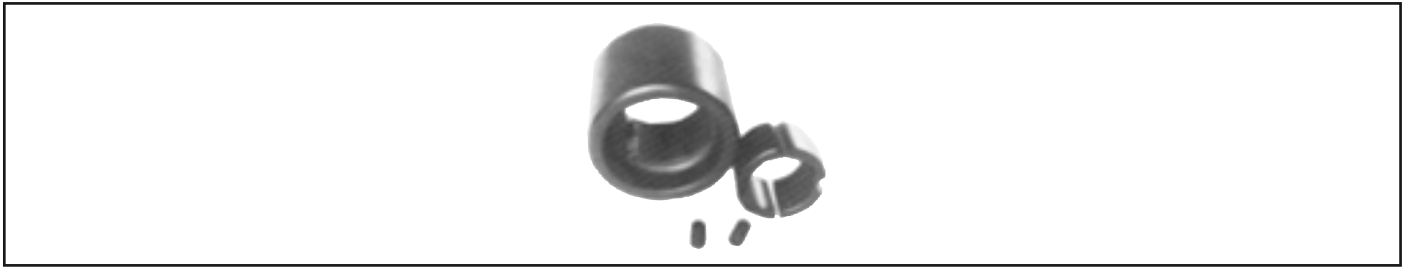

Außendurchmesser x Breite Outside diameter x width (mm)	Taper-Buchse Taper bushing	Fr. Stück ohne Buchse each without bushing	Außendurchmesser x Breite Outside diameter x width (mm)	Taper-Buchse Taper bushing	Fr. Stück ohne Buchse each without bushing
63 x 50	1108	88,48	224 x 50	2517	233,92
80 x 50	1210	99,36	224 x 80	2517	354,56
80 x 80	1615	122,08	224 x 100	3020	407,68
90 x 50	1615	131,68	224 x 125	3030	466,08
90 x 80	1615	138,08	224 x 160	3030	538,88
90 x 100	1615	157,44	250 x 80	2517	391,68
100 x 50	1615	146,24	250 x 100	3020	452,00
100 x 80	1615	167,20	250 x 125	3030	529,92
100 x 100	1615	193,28	250 x 160	3030	611,52
125 x 50	2012	172,00	280 x 100	3020	512,16
125 x 80	2517	205,60	280 x 125	3030	600,80
125 x 100	2517	237,44	280 x 160	3535	703,68
125 x 125	2517	246,40	280 x 200	4040	832,96
140 x 50	2012	198,56	315 x 100	3020	568,96
140 x 80	2517	219,84	315 x 125	3030	716,00
140 x 100	3020	260,48	315 x 160	3535	817,12
140 x 125	3030	276,48	315 x 200	4040	976,64
150 x 50	2012	209,12	355 x 100	3030	655,84
150 x 80	2517	237,44	355 x 125	3030	797,60
150 x 100	3020	278,24	355 x 160	3535	953,60
150 x 125	3030	288,96	355 x 200	4040	1.125,44
150 x 160	3030	322,56	400 x 100	3535	840,16
160 x 50	2012	219,84	400 x 125	3535	953,60
160 x 80	2517	253,44	400 x 160	3535	1.104,16
160 x 100	3020	292,48	400 x 200	4040	1.304,48
160 x 125	3030	297,76	450 x 160	3535	1.283,20
160 x 160	3030	358,08	450 x 200	4040	1.515,36
180 x 80	2517	283,52	500 x 160	4040	1.465,76
180 x 100	3020	329,60	500 x 200	4545	1.726,24
180 x 125	3030	352,64	560 x 160	4040	1.822,08
180 x 160	3030	412,96	560 x 200	4545	2.114,56
200 x 80	2517	313,76	630 x 160	4545	1.992,16
200 x 100	3020	361,60	630 x 200	5050	2.350,24
200 x 125	3030	405,92			
200 x 160	3030	466,08			

Taper-Buchse Taper bushing	1108	1210	1615	2012	2517	3020	3030	3535	4040	4545	5050
Bohrung d ₂ (mm) von ... bis ... Bore d ₂ (mm) from ... to ...	10-28	11-32	14-42	14-50	16-60	25-75	35-75	35-90	40-100	55-110	70-125
Fr./Stück each	12,96	18,40	23,04	24,64	37,60	50,24	66,08	127,04	178,56	227,20	347,20

Bohrungsdurchmesser d₂ siehe Seite 3.
Bore diameters d₂ see page 3.

Material: EN-GJL 200 – DIN EN 1561
Material: EN-GJL 200 – DIN EN 1561

Fertigungstechnische Änderungen vorbehalten.
We reserve the right to make technical changes.

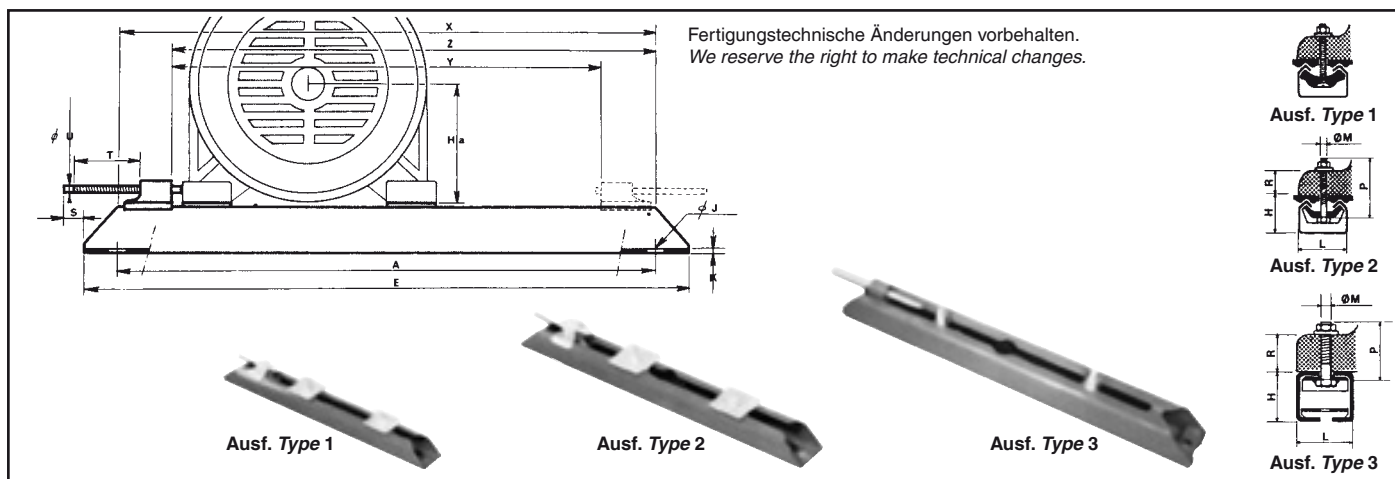

Bezeichnung Part number	S71/6VS	N300/6VS	S100/8VS	N400/8VS	S132/10VS	N600/10VS	S180/12VS	S225/16GS	S280/20GS	S355/24GS
Ausführung Type	1	1	2	2	2	2	2	3	3	3
Motorachshöhe Motor shaft centre height Ha (mm)	56/63/71	80	80/90/100	100/112	100/112/132	160	160/180	200/225	250/280	315/355
Abmessungen Dimensions	A (mm)	280,0	343,0	355,0	455,0	480,0	580,0	630,0	800,0	1000,0
	E (mm)	312,0	375,0	395,0	495,0	530,0	630,0	686,0	864,0	1072,0
	H (mm)	28,0	28,0	40,0	40,0	49,5	49,5	60,5	75,0	100,0
	Ø J (mm)	10,5	10,5	13,0	13,0	15,0	15,0	19,0	19,0	27,0
	K (mm)	1,5	1,5	2,5	2,5	7,0	7,0	7,0	8,0	10,0
	L (mm)	40,2	40,2	50,0	50,0	60,0	60,0	75,0	90,0	112,0
	Ø M (mm)	6,0	6,0	8,0	8,0	10,0	10,0	12,0	16,0	20,0
	P (mm)	35,0	35,0	45,0	45,0	55,0	55,0	70,0	70,0	80,0
	R (mm)	13,0	13,0	18,5	18,5	23,5	23,5	34,0	41,0	48,0
	S (mm)	20,0	20,0	30,0	32,0	37,0	37,0	50,0	167,0	200,0
T (mm)	75,0	75,0	97,0	97,0	119,0	119,0	154,0	300,0	360,0	
□ U (mm)	6,0	6,0	8,0	8,0	9,0	9,0	12,0	16,0	19,0	
Nutzlänge Working length	X (mm)	262,0	325,0	324,0	424,0	442,0	542,0	—	—	—
	Y (mm)	206,0	265,0	264,0	354,0	368,0	473,0	623,0	764,0	946,0
	Z (mm)	234,0	295,0	294,0	394,0	405,0	502,5	698,0	864,0	1064,0
Gewicht je Paar Weight per pair (≈ kg)	1,120	1,300	2,970	3,500	6,100	6,500	10,650	16,200	36,100	59,500
Fr./Satz set	141,60	174,24	203,84	237,44	301,28	327,84	469,76	1.001,44	1.582,72	2.359,04

Vorteile der Optibelt MS Motorspannschienen

- Sie sind unzerbrechlich, weil sie ganz aus Stahl hergestellt sind.
- Die genormten Motorbefestigungsschrauben sind leicht auswechselbar, z. B. bei starken Motorfüßen oder bei zu befestigenden Zusatzteilen.
- Leichtes Aufsetzen des Motors:
Nach dem Einstecken der Motorbefestigungsschrauben in die Motorfüße wird das Ganze mit den Spezialmuttern in die Stahlspannschienen eingeschoben.
- Alle Einzelteile sind bestens gegen Korrosion durch entsprechende Oberflächenbehandlung geschützt.
- Stahlspannschienen: phosphatiert und grün einbrennlackiert.
- Spannschrauben: elektro-verzinkt.
- Motorbefestigungsschrauben:
für S 71 bis S 180 elektro-verzinkt,
für S 225 bis S 355 phosphatiert und mit Rostschutz versehen.

Die mit „S“ gekennzeichneten Abmessungen (z. B. S 71) entsprechen der französischen Norm U.T.E. C-51106.

Die Zahlen 71, 100, 132, 180, 225, 280 und 355 bezeichnen die maximalen Motorachshöhen in mm für den jeweiligen Spannschienen-Typ.

Die Zahlen hinter dem Schrägstrich (6, 8, 10, 12, 16, 20, 24) geben den Gewindedurchmesser der entsprechenden Befestigungsschrauben an (6 = M6).

Die Buchstaben VS bzw. GS bezeichnen die Ausführung der Spannkloben:

VS = verschiebbarer Spannkloben

GS = geschweißter Spannkloben

Die Typen N 300, N 400 und N 600 sind nicht genormt. Es handelt sich jeweils um die verlängerte Ausführung der genormten Schiene, sodass hierfür die gleichen Ersatzteile verwendet werden können.

Ein Satz Spannschienen besteht aus 2 Schienen inklusive aller Befestigungsteile.

Advantages of Optibelt MS motor slide rails

- Rugged all steel construction.
- The standard motor fixing bolts are easily replaced, e. g. for heavier motor feet or for the mounting of auxiliary equipment.
- Easy motor mounting. After inserting the motor mounting bolts into the motor feet, the whole unit is pushed into the rails.
- All parts are fully corrosion protected.
- Steel tension rails: Phosphated and stone-enamelled in green.
- The adjusting bolts are zinc plated.
- The motor mounting bolts:
for S 71 up to S 180 are zinc plated,
for S 225 up to S 355 are phosphated and rust protected.

The sizes marked with "S" (e. g. S 71) correspond to the French standard U.T.E. C-51106.

The numbers 71, 100, 132, 180, 225, 280, and 355 indicate the max. motor shaft height in mm for the individual rail types.

The numbers following the slash (6, 8, 10, 12, 16, 20, 24) indicate the thread diameters of the fixing bolts (6 = M6).

The letters VS and GS indicate the design of the adjusting screw bracket:

VS = sliding bracket

GS = fixed bracket

Slide rail part number N 300, N 400, and N 600 are not standardised. They are longer than the standard slide rails but all of the same spare parts can be used.

One set of slide rails consists of 2 rails with all fixing parts.

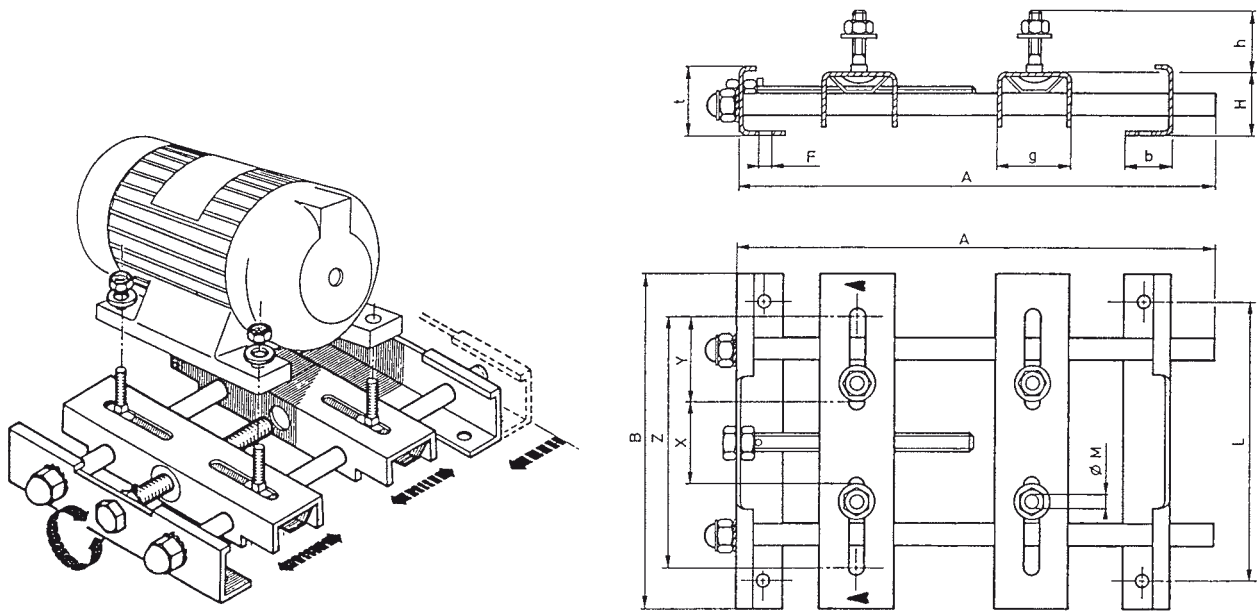

Fertigungstechnische Änderungen vorbehalten. We reserve the right to make technical changes.

Bezeichnung <i>Part number</i>	MS 100	MS 132
Motorachshöhe <i>Motor shaft height</i> Ha (mm)	100,0	132,0
A (mm)	300,0	450,0
B (mm)	180,0	265,0
F (mm)	10,0	13,0
H (mm)	35,0	50,0
L (mm)	150,0	225,0
M	M 8 x 35	M 10 x 40
b (mm)	30,0	45,0
g (mm)	40,0	55,0
h (mm)	35,0	40,0
t (mm)	40,0	55,0
u (mm)	25,0	35,0
v (mm)	20,0	25,0
w (mm)	9,0	18,0
x (mm)	46,0	105,0
y (mm)	50,0	50,0
z (mm)	145,0	204,0
Gewicht <i>Weight</i> (≈ kg)	2,180	4,520
Fr./Stück <i>each</i>	223,36	358,08

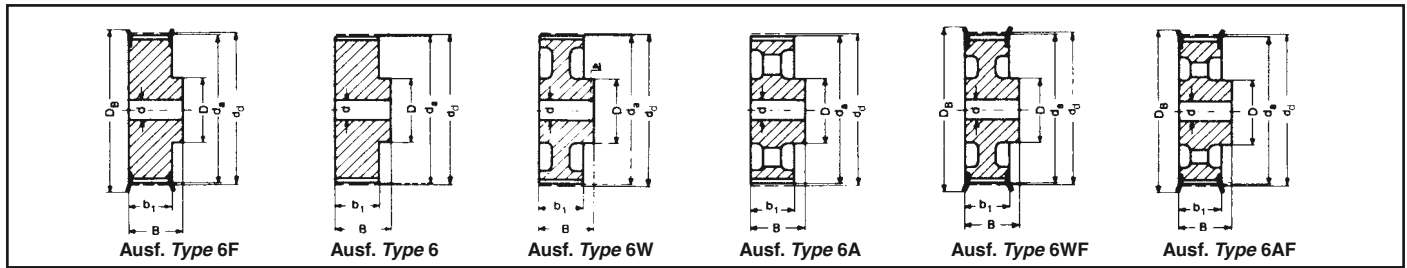

Profil Profile XL – Teilung Pitch 5,08 mm für Riemenbreite for belt width 025, 031, 037

Designation	No. of teeth	Type	Material	d _d (mm)	d _a (mm)	D _B (mm)	b ₁ (mm)	B (mm)	D (mm)	Pilot bore d (mm)	Finished bore d _{max} (mm)	Grub screw	Weight (≈ kg)	Fr. Stück each
10 XL 037	10	6F	St	16,17	15,66	23	14,3	19,8	9,5	5,0	6,4	M3	0,02	13,92
11 XL 037	11	6F	St	17,79	17,28	23	14,3	19,8	9,5	5,0	6,4	M3	0,02	15,36
12 XL 037	12	6F	St	19,40	18,89	25	14,3	19,8	12,7	5,0	7,9	M3	0,03	16,32
14 XL 037	14	6F	St	22,64	22,13	28	14,3	19,8	14,3	6,0	9,5	M4	0,04	17,60
15 XL 037	15	6F	St	24,26	23,75	28	14,3	19,8	15,9	6,0	11,1	M4	0,04	17,92
16 XL 037	16	6F	St	25,87	25,36	32	14,3	19,8	17,5	6,0	12,7	M4	0,05	18,72
18 XL 037	18	6F	St	29,11	28,60	36	14,3	19,8	19,0	6,0	14,3	M4	0,06	19,36
20 XL 037	20	6F	St	32,34	31,83	38	14,3	22,2	23,8	6,0	17,5	M4	0,08	21,76
21 XL 037	21	6F	St	33,96	33,45	38	14,3	22,2	23,8	6,0	17,5	M4	0,09	22,24
22 XL 037	22	6F	St	35,57	35,06	42	14,3	22,2	25,4	6,0	19,1	M4	0,10	22,72
24 XL 037	24	6F	St	38,81	38,30	44	14,3	22,2	27,0	6,0	20,6	M4	0,12	23,68
26 XL 037	26	6F	St	42,04	41,53	48	14,3	22,2	30,0	6,0	23,0	M4	0,14	24,48
28 XL 037	28	6F	St	45,28	44,77	51	14,3	22,2	30,2	6,0	23,0	M4	0,16	25,28
30 XL 037	30	6F	St	48,51	48,00	54	14,3	22,2	34,9	6,0	23,0	M4	0,19	26,56
32 XL 037	32	6	Al	51,74	51,23	—	14,3	25,4	38,0	8,0	23,0	M4	0,11	30,72
36 XL 037	36	6	Al	58,21	57,70	—	14,3	25,4	38,0	8,0	23,0	M4	0,13	32,16
40 XL 037	40	6	Al	64,68	64,17	—	14,3	25,4	38,0	8,0	23,0	M4	0,17	35,84
42 XL 037	42	6W	Al	67,91	67,40	—	14,3	25,4	38,0	8,0	23,0	M4	0,13	36,80
44 XL 037	44	6W	Al	71,15	70,64	—	14,3	25,4	38,0	8,0	23,0	M4	0,15	40,80
48 XL 037	48	6W	Al	77,62	77,11	—	14,3	25,4	38,0	8,0	23,0	M4	0,16	48,16
60 XL 037	60	6A	Al	97,02	96,51	—	14,3	25,4	38,0	8,0	23,0	M4	0,18	64,64
72 XL 037	72	6A	Al	116,43	115,92	—	14,3	25,4	38,0	8,0	23,0	M4	0,23	76,00

Profil Profile L – Teilung Pitch 9,525 mm für Riemenbreite for belt width 050

10 L 050	10	6F	St	30,32	29,56	36	19	26	22	6,0	13,0	—	0,11	15,20
12 L 050	12	6F	St	36,38	35,62	42	19	26	28	6,0	17,0	—	0,19	19,04
13 L 050	13	6F	St	39,41	38,65	44	19	26	30	6,0	19,0	—	0,21	20,32
14 L 050	14	6F	St	42,45	41,68	48	19	26	33	8,0	20,0	—	0,25	23,20
15 L 050	15	6F	St	45,48	44,72	51	19	26	36	8,0	23,0	—	0,30	24,48
16 L 050	16	6F	St	48,51	47,75	54	19	26	38	8,0	23,0	—	0,33	25,76
17 L 050	17	6F	St	51,54	50,78	57	19	26	40	10,0	24,0	—	0,36	28,00
18 L 050	18	6F	St	54,57	53,81	60	19	26	40	10,0	24,0	—	0,41	30,08
19 L 050	19	6F	St	57,61	56,84	60	19	26	40	10,0	24,0	—	0,45	31,20
20 L 050	20	6F	St	60,64	59,88	66	19	26	46	10,0	28,0	—	0,50	32,64
21 L 050	21	6F	St	63,67	62,91	71	19	26	46	10,0	28,0	—	0,55	33,60
22 L 050	22	6F	St	66,70	65,94	75	19	26	50	10,0	30,0	—	0,62	34,88
24 L 050	24	6F	St	72,77	72,00	79	19	26	50	12,0	30,0	—	0,68	39,20
26 L 050	26	6F	St	78,83	78,07	87	19	26	50	12,0	30,0	—	0,82	45,92
28 L 050	28	6F	St	84,89	84,13	91	19	26	50	12,0	30,0	—	0,92	50,24
30 L 050	30	6F	St	90,96	90,20	97	19	26	50	12,0	30,0	—	1,10	54,56
32 L 050	32	6F	St	97,02	96,26	103	19	26	50	12,0	30,0	—	1,20	59,20
36 L 050	36	6WF	GG	109,15	108,38	115	19	26	50	12,0	30,0	—	1,00	69,12
40 L 050	40	6WF	GG	121,28	120,51	127	19	26	50	12,0	30,0	—	1,10	77,60
44 L 050	44	6AF	GG	133,40	132,64	140	19	26	50	12,0	30,0	—	1,20	85,12
48 L 050	48	6AF	GG	145,53	144,77	152	19	26	50	12,0	30,0	—	1,30	93,76
60 L 050	60	6A	GG	181,91	181,15	—	19	28	50	15,0	30,0	—	1,30	96,80
72 L 050	72	6A	GG	218,30	217,53	—	19	28	50	15,0	30,0	—	1,70	111,36
84 L 050	84	6A	GG	254,68	253,92	—	19	28	50	15,0	30,0	—	1,90	125,76

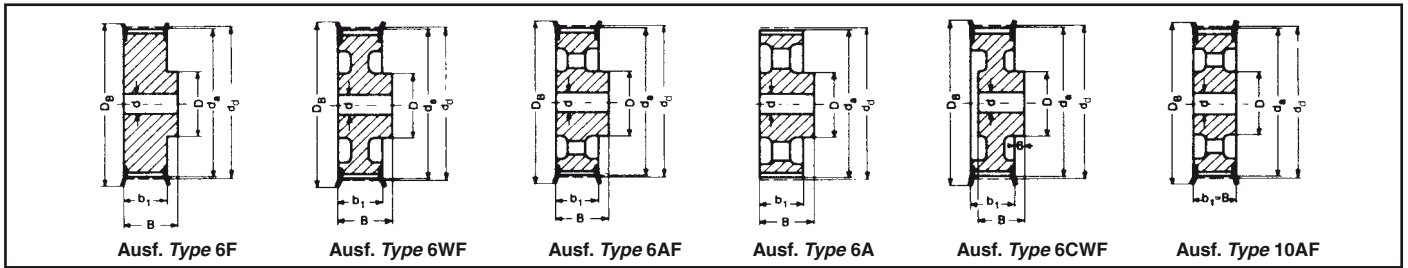

Profil Profile L – Teilung Pitch 9,525 mm für Riemenbreite for belt width 075

Bezeichnung Part No.	Anzahl der Zähne No. of teeth	Aus- führung Type	Material	d _d (mm)	d _a (mm)	D _B (mm)	b ₁ (mm)	B (mm)	D (mm)	Vor- bohrung Pilot bore d (mm)	Fertig- bohrung Finished bore d _{max} (mm)	Gewicht Weight (≈ kg)	Fr. Stück each
10 L 075	10	6F	St	30,32	29,56	36	25	32	22	6	13	0,15	18,08
12 L 075	12	6F	St	36,38	35,62	42	25	32	28	8	17	0,23	21,92
13 L 075	13	6F	St	39,41	38,65	44	25	32	30	8	19	0,26	24,32
14 L 075	14	6F	St	42,45	41,68	48	25	32	33	8	20	0,32	25,92
15 L 075	15	6F	St	45,48	44,72	51	25	32	36	8	23	0,35	27,20
16 L 075	16	6F	St	48,51	47,75	54	25	32	38	8	23	0,42	28,32
17 L 075	17	6F	St	51,54	50,78	57	25	32	40	10	24	0,45	30,88
18 L 075	18	6F	St	54,57	53,81	60	25	32	40	10	24	0,51	33,44
19 L 075	19	6F	St	57,61	56,84	60	25	32	40	10	24	0,57	34,40
20 L 075	20	6F	St	60,64	59,88	66	25	32	46	10	28	0,63	35,84
21 L 075	21	6F	St	63,67	62,91	71	25	32	46	10	28	0,70	37,60
22 L 075	22	6F	St	66,70	65,94	75	25	32	50	10	30	0,75	39,52
24 L 075	24	6F	St	72,77	72,00	79	25	32	50	12	30	0,85	43,68
26 L 075	26	6F	St	78,83	78,07	87	25	32	50	12	30	1,00	51,04
28 L 075	28	6F	St	84,89	84,13	91	25	32	50	12	30	1,20	53,44
30 L 075	30	6F	St	90,96	90,20	97	25	32	50	12	30	1,40	60,32
32 L 075	32	6F	St	97,02	96,26	103	25	32	50	12	30	1,50	64,64
36 L 075	36	6WF	GG	109,15	108,38	115	25	32	55	12	32	1,30	77,60
40 L 075	40	6WF	GG	121,28	120,51	127	25	32	60	12	35	1,60	88,16
44 L 075	44	6AF	GG	133,40	132,64	140	25	32	60	12	35	1,70	100,48
48 L 075	48	6AF	GG	145,53	144,77	152	25	32	60	12	35	1,90	111,36
60 L 075	60	6A	GG	181,91	181,15	—	26	35	60	15	35	1,80	117,28
72 L 075	72	6A	GG	218,30	217,53	—	26	35	60	15	35	2,30	130,40
84 L 075	84	6A	GG	254,68	253,92	—	26	35	60	15	35	2,50	150,24

Profil Profile L – Teilung Pitch 9,525 mm für Riemenbreite for belt width 100

10 L 100	10	6F	St	30,32	29,56	36	31	38	22	6	13	0,81	20,96
12 L 100	12	6F	St	36,38	35,62	42	31	38	28	8	17	0,29	24,32
13 L 100	13	6F	St	39,41	38,65	44	31	38	30	8	19	0,30	26,88
14 L 100	14	6F	St	42,45	41,68	48	31	38	33	8	20	0,38	28,32
15 L 100	15	6F	St	45,48	44,72	51	31	38	36	8	23	0,40	30,08
16 L 100	16	6F	St	48,51	47,75	54	31	38	38	8	23	0,51	30,88
17 L 100	17	6F	St	51,54	50,78	57	31	38	40	10	24	0,54	33,12
18 L 100	18	6F	St	54,57	53,81	60	31	38	40	10	24	0,62	34,88
19 L 100	19	6F	St	57,61	56,84	60	31	38	40	10	24	0,69	36,48
20 L 100	20	6F	St	60,64	59,88	66	31	38	46	10	28	0,76	39,20
21 L 100	21	6F	St	63,67	62,91	71	31	38	46	10	28	0,82	41,44
22 L 100	22	6F	St	66,70	65,94	75	31	38	50	10	30	0,92	45,92
24 L 100	24	6F	St	72,77	72,00	79	31	38	50	12	30	1,10	51,36
26 L 100	26	6F	St	78,83	78,07	87	31	38	50	12	30	1,30	55,20
28 L 100	28	6F	St	84,89	84,13	91	31	38	50	12	30	1,40	59,36
30 L 100	30	6F	St	90,96	90,20	97	31	38	50	12	30	1,70	63,84
32 L 100	32	6F	St	97,02	96,26	103	31	38	50	12	30	1,80	68,32
36 L 100	36	6CWF	GG	109,15	108,38	115	32	32	55	12	32	1,50	81,60
40 L 100	40	6CWF	GG	121,28	120,51	127	32	32	60	12	35	1,80	89,92
44 L 100	44	10AF	GG	133,40	132,64	140	32	32	60	12	35	1,90	108,16
48 L 100	48	10AF	GG	145,53	144,77	152	32	32	60	12	35	2,10	113,92
60 L 100	60	6A	GG	181,91	181,15	—	32	35	60	15	35	2,00	116,80
72 L 100	72	6A	GG	218,30	217,53	—	32	35	60	15	35	2,50	134,56
84 L 100	84	6A	GG	254,68	253,92	—	32	35	60	15	35	2,70	151,36

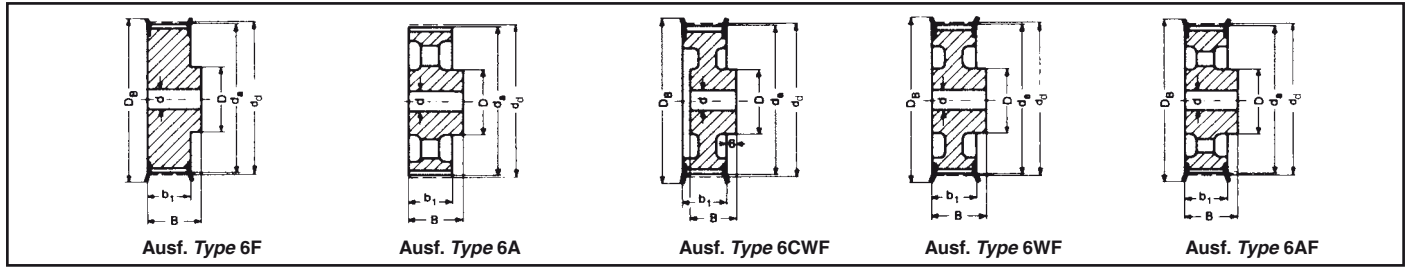

Profil Profile H – Teilung Pitch 12,7 mm für Riemenbreite for belt width 075

Bezeichnung Part No.	Anzahl der Zähne No. of teeth	Aus- führung Type	Material	d _d (mm)	d _a (mm)	D _B (mm)	b ₁ (mm)	B (mm)	D (mm)	Vor- bohrung Pilot bore d (mm)	Fertig- bohrung Finished bore d _{max} (mm)	Gewicht Weight (≈ kg)	Fr. Stück each
14 H 075	14	6F	St	56,60	55,22	64,0	26,4	40	40	10	24	0,50	33,12
16 H 075	16	6F	St	64,67	63,31	70,0	26,4	40	46	10	26	0,60	39,04
18 H 075	18	6F	St	72,77	71,39	79,0	26,4	40	54	12	32	0,80	43,36
19 H 075	19	6F	St	76,81	75,44	82,5	26,4	40	58	12	35	1,00	49,28
20 H 075	20	6F	St	80,85	79,48	87,0	26,4	40	62	12	35	1,10	52,16
21 H 075	21	6F	St	84,89	83,52	91,0	26,4	40	67	12	38	1,20	53,60
22 H 075	22	6F	St	88,94	87,56	94,0	26,4	40	70	12	38	1,40	55,68
24 H 075	24	6F	St	97,02	95,65	102,0	26,4	40	75	12	42	1,60	62,56
26 H 075	26	6F	St	105,11	103,73	112,0	26,4	40	80	15	45	1,80	70,72
28 H 075	28	6F	GG	113,19	111,82	120,0	26,4	40	80	15	45	2,00	74,88
30 H 075	30	6F	GG	121,28	119,90	128,0	26,4	40	80	15	45	2,10	78,88
32 H 075	32	6F	GG	129,36	127,99	135,0	26,4	40	70	15	45	2,20	90,40
36 H 075	36	6F	GG	145,53	144,16	152,0	26,4	40	80	20	45	2,40	100,00
40 H 075	40	6F	GG	161,70	160,33	168,0	26,4	40	80	20	45	2,80	113,12
44 H 075	44	6AF	GG	177,87	176,50	184,0	26,4	40	80	20	45	2,70	119,84
48 H 075	48	6AF	GG	194,04	192,67	200,0	26,4	40	90	20	50	3,00	126,40

Profil Profile H – Teilung Pitch 12,7 mm für Riemenbreite for belt width 100

14 H 100	14	6F	St	56,60	55,22	63	31	41	40	10	24	0,65	35,04
16 H 100	16	6F	St	64,68	63,31	71	31	41	46	10	28	0,85	42,88
18 H 100	18	6F	St	72,77	71,39	79	31	41	54	12	32	1,10	48,00
19 H 100	19	6F	St	76,81	75,44	83	31	41	58	12	34	1,20	52,32
20 H 100	20	6F	St	80,85	79,48	87	31	41	62	12	35	1,40	56,32
21 H 100	21	6F	St	84,89	83,52	91	31	41	67	12	38	1,60	60,48
22 H 100	22	6F	St	88,94	87,56	93	31	41	70	12	41	1,70	62,72
24 H 100	24	6F	St	97,02	95,65	103	31	41	75	12	45	2,00	71,20
26 H 100	26	6CWF	GG	105,11	103,73	111	32	32	55	15	32	1,40	80,16
28 H 100	28	6CWF	GG	113,19	111,82	119	32	32	60	15	35	1,60	84,48
30 H 100	30	6CWF	GG	121,28	119,90	127	32	32	60	15	35	1,70	89,92
32 H 100	32	6WF	GG	129,36	127,99	135	32	40	70	20	40	2,20	104,80
36 H 100	36	6WF	GG	145,53	144,16	152	32	40	80	20	45	3,00	113,92
40 H 100	40	6AF	GG	161,70	160,33	168	32	40	80	20	45	2,80	132,00
44 H 100	44	6AF	GG	177,87	176,50	184	32	40	80	20	45	3,10	137,12
48 H 100	48	6AF	GG	194,04	192,67	200	32	40	80	20	45	3,30	150,24
60 H 100	60	6A	GG	242,55	241,18	—	34	45	80	20	45	5,50	185,76
72 H 100	72	6A	GG	291,06	289,69	—	34	45	80	20	45	7,10	247,20
84 H 100*	84	6A	GG	339,57	338,20	—	34	45	80	20	45	8,20	297,76
96 H 100*	96	6A	GG	388,08	386,71	—	34	45	80	20	45	9,90	356,48
120 H 100*	120	6A	GG	485,10	483,73	—	34	50	90	20	50	13,10	488,16

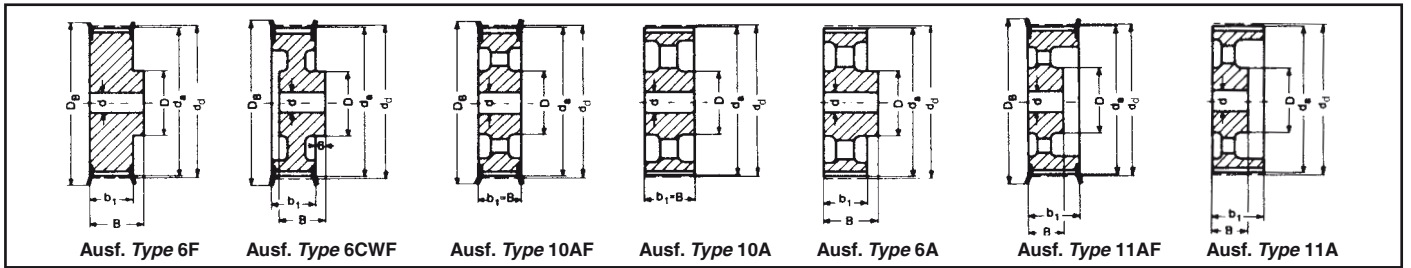

Profil Profile H – Teilung Pitch 12,7 mm für Riemenbreite for belt width 150

Bezeichnung Part No.	Anzahl der Zähne No. of teeth	Aus- führung Type	Material	d _d (mm)	d _a (mm)	D _B (mm)	b ₁ (mm)	B (mm)	D (mm)	Vor- bohrung Pilot bore d (mm)	Fertig- bohrung Finished bore d _{max} (mm)	Gewicht Weight (≈ kg)	Fr. Stück each
14 H 150	14	6F	St	56,60	55,22	63	44	54	40	12	24	0,82	41,44
16 H 150	16	6F	St	64,68	63,31	71	44	54	46	12	28	1,10	50,72
18 H 150	18	6F	St	72,77	71,39	79	44	54	54	12	32	1,50	57,28
19 H 150	19	6F	St	76,81	75,44	83	44	54	58	12	34	1,70	64,16
20 H 150	20	6F	St	80,85	79,48	87	44	54	62	12	35	1,80	69,12
21 H 150	21	6F	St	84,89	83,52	91	44	54	67	12	38	2,20	74,56
22 H 150	22	6F	St	88,94	87,56	93	44	54	70	12	41	2,30	79,36
24 H 150	24	6F	St	97,02	95,65	103	44	54	75	12	45	2,60	86,72
26 H 150	26	6CWF	GG	105,11	103,73	111	45	35	55	15	32	1,70	91,04
28 H 150	28	6CWF	GG	113,19	111,82	119	45	35	60	15	35	1,90	97,28
30 H 150	30	6CWF	GG	121,28	119,90	127	45	35	60	15	35	2,10	102,88
32 H 150	32	6CWF	GG	129,36	127,99	135	45	45	70	20	40	2,60	117,60
36 H 150	36	6CWF	GG	145,53	144,16	152	45	45	80	20	45	3,20	130,08
40 H 150	40	10AF	GG	161,70	160,33	168	45	45	80	20	45	3,80	156,96
44 H 150	44	10AF	GG	177,87	176,50	184	45	45	80	20	45	3,70	163,04
48 H 150	48	10AF	GG	194,04	192,67	200	45	45	80	20	45	4,00	176,48
60 H 150	60	10A	GG	242,55	241,18	—	46	46	85	20	48	5,10	230,88
72 H 150	72	10A	GG	291,06	289,69	—	46	46	85	20	48	7,90	279,52
84 H 150*	84	10A	GG	339,57	338,20	—	46	46	85	20	48	8,90	348,48
96 H 150*	96	10A	GG	388,08	386,71	—	46	46	85	20	48	10,10	396,96
120 H 150*	120	6A	GG	485,10	483,73	—	46	55	95	24	55	17,20	571,20

Profil Profile H – Teilung Pitch 12,7 mm für Riemenbreite for belt width 200

14 H 200	14	6F	St	56,60	55,22	63	58	68	40	12	24	1,1	47,04
16 H 200	16	6F	St	64,68	63,31	71	58	68	46	15	28	1,4	59,36
18 H 200	18	6F	St	72,77	71,39	79	58	68	54	15	32	1,8	67,20
19 H 200	19	6F	St	76,81	75,44	83	58	68	58	15	34	2,1	74,08
20 H 200	20	6F	St	80,85	79,48	87	58	68	62	15	35	2,3	77,92
21 H 200	21	6F	St	84,89	83,52	91	58	68	67	15	38	2,6	84,48
22 H 200	22	6F	St	88,94	87,56	93	58	68	70	15	41	2,8	88,64
24 H 200	24	6F	St	97,02	95,65	103	58	68	75	15	45	3,4	100,00
26 H 200	26	6CWF	GG	105,11	103,73	111	58	42	60	15	35	2,3	104,48
28 H 200	28	6CWF	GG	113,19	111,82	119	58	42	60	15	35	2,5	112,32
30 H 200	30	6CWF	GG	121,28	119,90	127	58	42	70	15	40	2,9	119,84
32 H 200	32	6CWF	GG	129,36	127,99	135	58	47	70	20	40	3,2	128,32
36 H 200	36	6CWF	GG	145,53	144,16	152	58	47	80	20	45	3,8	149,44
40 H 200	40	11AF	GG	161,70	160,33	168	58	45	80	20	45	4,1	182,72
44 H 200	44	11AF	GG	177,87	176,50	184	58	45	80	20	45	4,4	194,24
48 H 200	48	11AF	GG	194,04	192,67	200	58	45	85	20	48	5,1	214,72
60 H 200	60	11A	GG	242,55	241,18	—	60	50	90	20	50	7,1	273,44
72 H 200	72	11A	GG	291,06	289,69	—	60	50	90	20	50	8,0	358,56
84 H 200*	84	11A	GG	339,57	338,20	—	60	50	90	20	50	12,0	425,44
96 H 200*	96	11A	GG	388,08	386,71	—	60	50	90	20	50	13,6	484,16
120 H 200*	120	10A	GG	485,10	483,73	—	60	60	100	24	57	16,6	684,64

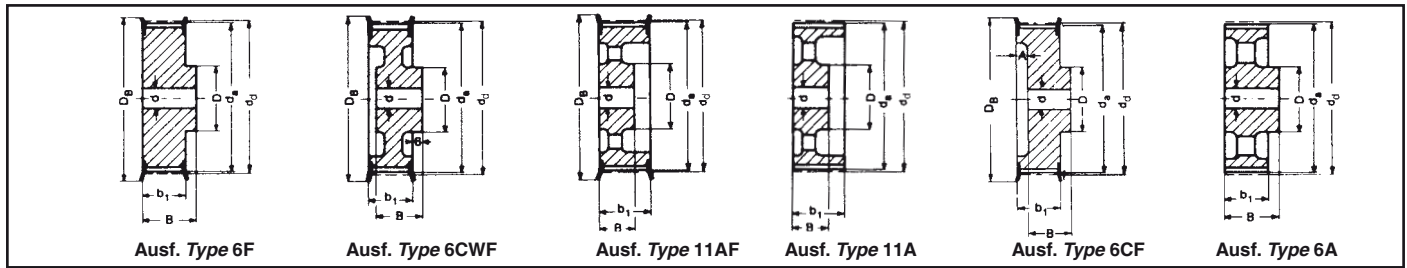

Profil Profile H – Teilung Pitch 12,7 mm für Riemenbreite for belt width 300

Bezeichnung Part No.	Anzahl der Zähne No. of teeth	Aus- führung Type	Material	d _d (mm)	d _a (mm)	D _B (mm)	b ₁ (mm)	B (mm)	D (mm)	A (mm)	Vor- bohrung Pilot bore d (mm)	Fertig- bohrung Finished bore d _{max} (mm)	Gewicht Weight (≈ kg)	Fr. Stück each
16 H 300	16	6F	St	64,68	63,31	71	84	94	46	—	15	28	2,0	72,48
18 H 300	18	6F	St	72,77	71,39	79	84	94	54	—	15	32	2,6	82,40
19 H 300	19	6F	St	76,81	75,44	83	84	94	58	—	15	34	2,9	90,40
20 H 300	20	6F	St	80,85	79,48	87	84	94	62	—	15	35	3,2	96,32
21 H 300	21	6F	St	84,89	83,52	91	84	94	67	—	15	38	3,6	104,48
22 H 300	22	6F	St	88,94	87,56	93	84	94	70	—	15	41	4,0	110,24
24 H 300	24	6F	St	97,02	95,65	103	84	94	75	—	15	45	4,7	124,96
26 H 300	26	6CWF	GG	105,11	103,73	111	84	57	60	—	15	35	3,3	158,56
28 H 300	28	6CWF	GG	113,19	111,82	119	84	57	60	—	15	35	3,6	174,40
30 H 300	30	6CWF	GG	121,28	119,90	127	84	57	70	—	15	40	4,2	192,64
32 H 300	32	6CWF	GG	129,36	127,99	135	84	57	70	—	20	40	4,3	213,12
36 H 300	36	6CWF	GG	145,53	144,16	152	84	57	80	—	20	45	5,2	236,96
40 H 300	40	11AF	GG	161,70	160,33	168	84	55	80	—	20	45	5,6	251,04
44 H 300	44	11AF	GG	177,87	176,50	184	84	55	80	—	20	45	5,9	264,32
48 H 300	48	11AF	GG	194,04	192,67	200	84	55	85	—	20	48	6,6	291,68
60 H 300	60	11A	GG	242,55	241,18	—	86	55	100	—	20	57	9,9	368,64
72 H 300	72	11A	GG	291,06	289,69	—	86	55	100	—	20	57	13,0	476,00
84 H 300*	84	11A	GG	339,57	338,20	—	86	55	100	—	20	57	15,1	542,88
96 H 300*	96	11A	GG	388,08	386,71	—	86	55	100	—	20	57	18,2	629,92
120 H 300*	120	11A	GG	485,10	483,73	—	86	65	110	—	24	62	26,0	871,04

Profil Profile XH – Teilung Pitch 22,25 mm für Riemenbreite for belt width 200

18 XH 200*	18	6CF	GG	127,34	124,55	142	64,4	60	85	18	20	50	5,0	auf Anfrage on request
20 XH 200*	20	6CF	GG	141,49	138,69	155	64,4	60	95	18	20	55	6,0	
22 XH 200*	22	6CF	GG	155,64	152,84	170	64,4	60	110	18	20	65	7,2	
24 XH 200*	24	6CF	GG	169,79	166,69	184	64,4	60	125	18	25	70	8,6	
26 XH 200*	26	6CF	GG	183,94	181,14	198	64,4	60	140	18	25	80	10,1	
28 XH 200*	28	6CWF	GG	198,08	195,29	212	64,4	60	120	18	25	70	9,6	
30 XH 200*	30	6CWF	GG	212,23	209,44	227	64,4	60	120	18	25	70	10,4	
32 XH 200*	32	6CWF	GG	226,38	223,59	240	64,4	60	130	18	25	75	11,2	
40 XH 200*	40	6CWF	GG	282,98	280,18	297	64,4	60	140	18	25	80	16,0	
48 XH 200*	48	6A	GG	339,57	336,78	—	65,0	80	150	—	30	85	18,4	
60 XH 200*	60	6A	GG	424,47	421,67	—	65,0	80	150	—	30	85	24,3	
72 XH 200*	72	6A	GG	509,36	506,57	—	65,0	80	150	—	40	85	28,1	
84 XH 200*	84	6A	GG	594,25	591,46	—	65,0	80	160	—	40	90	31,9	
96 XH 200*	96	6A	GG	679,15	676,35	—	65,0	80	160	—	40	90	37,0	

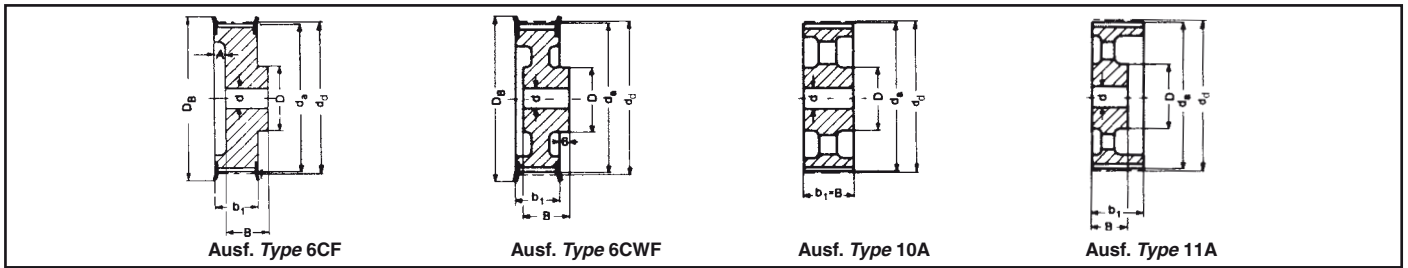

Profil Profile XH – Teilung Pitch 22,225 mm für Riemenbreite for belt width 300

Bezeichnung Part No.	Anzahl der Zähne No. of teeth	Aus- führung Type	Material	d _d (mm)	d _a (mm)	D _B (mm)	b ₁ (mm)	B (mm)	D (mm)	A (mm)	Vor- bohrung Pilot bore d (mm)	Fertig- bohrung Finished bore d _{max} (mm)	Gewicht Weight (≈ kg)	Fr. Stück each
18 XH 300*	18	6CF	GG	127,34	124,55	142	91,4	70	85	35	20	50	6,8	auf Anfrage on request
20 XH 300*	20	6CF	GG	141,49	138,69	155	91,4	70	95	35	20	55	7,4	
22 XH 300*	22	6CF	GG	155,64	152,84	170	91,4	70	110	35	20	65	9,0	
24 XH 300*	24	6CF	GG	169,79	166,69	184	91,4	70	125	35	25	70	10,6	
26 XH 300*	26	6CF	GG	183,94	181,14	198	91,4	70	140	35	25	80	13,0	
28 XH 300*	28	6CWF	GG	198,08	195,29	212	91,4	70	120	35	25	70	12,0	
30 XH 300*	30	6CWF	GG	212,23	209,44	227	91,4	70	120	35	25	70	13,0	
32 XH 300*	32	6CWF	GG	226,38	223,59	240	91,4	70	130	35	25	75	14,7	
40 XH 300*	40	6CWF	GG	282,98	280,18	297	91,4	70	140	35	25	80	19,9	
48 XH 300*	48	10A	GG	339,57	336,78	—	92,0	92	150	—	30	85	22,5	
60 XH 300*	60	10A	GG	424,47	421,67	—	92,0	92	150	—	30	85	31,5	
72 XH 300*	72	10A	GG	509,36	506,57	—	92,0	92	150	—	40	85	36,4	
84 XH 300*	84	10A	GG	594,25	591,46	—	92,0	92	160	—	40	90	43,4	
96 XH 300*	96	10A	GG	679,15	676,35	—	92,0	92	160	—	40	90	48,5	

Profil Profile XH – Teilung Pitch 22,225 mm für Riemenbreite for belt width 400

18 XH 400*	18	6CF	GG	127,34	124,55	142	118,4	85	85	47	20	50	8,5	auf Anfrage on request
20 XH 400*	20	6CF	GG	141,49	138,69	155	118,4	85	95	47	20	55	9,4	
22 XH 400*	22	6CF	GG	155,64	152,84	170	118,4	85	110	47	20	65	11,5	
24 XH 400*	24	6CF	GG	169,79	166,69	184	118,4	85	125	47	25	70	13,4	
26 XH 400*	26	6CF	GG	183,94	181,14	198	118,4	85	140	47	25	80	15,6	
28 XH 400*	28	6CWF	GG	198,08	195,29	212	118,4	85	120	47	25	70	14,5	
30 XH 400*	30	6CWF	GG	212,23	209,44	227	118,4	85	120	47	25	70	16,0	
32 XH 400*	32	6CWF	GG	226,38	223,59	240	118,4	85	130	47	25	75	18,0	
40 XH 400*	40	6CWF	GG	282,98	280,18	297	118,4	85	140	47	25	80	24,0	
48 XH 400*	48	11A	GG	339,57	336,78	—	119,0	92	150	—	30	85	30,8	
60 XH 400*	60	11A	GG	424,47	421,67	—	119,0	92	150	—	30	85	36,2	
72 XH 400*	72	11A	GG	509,36	506,57	—	119,0	92	150	—	40	85	42,7	
84 XH 400*	84	11A	GG	594,25	591,46	—	119,0	92	160	—	40	90	49,7	
96 XH 400*	96	11A	GG	679,15	676,35	—	119,0	92	160	—	40	90	59,9	

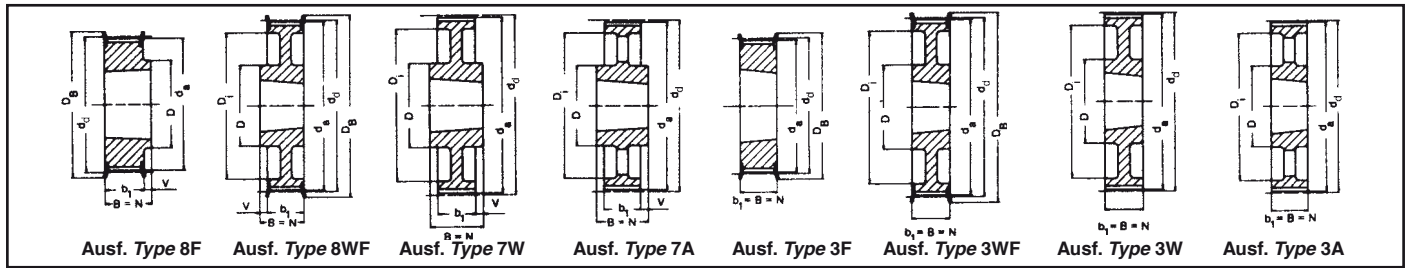

Profil Profile L – Teilung Pitch 9,525 mm für Riemenbreite for belt width 050

Bezeichnung Part No.	Anzahl der Zähne No. of teeth	Aus- füh- rung Type	Material	d _d (mm)	d _a (mm)	D _B (mm)	b ₁ (mm)	B (mm)	N (mm)	V (mm)	Z (mm)	D (mm)	D _i (mm)	Taper- Buchse Taper bushing	Gewicht ohne Buchse Weight without bushing (≈ kg)	Fr. Stück ohne Buchse each without bushing
TB 18 L 050	18	8F	St	54,57	53,81	60	19,0	22,0	22,0	3,0	—	44	—	1108	0,2	32,48
TB 19 L 050	19	8F	St	57,61	56,84	60	19,0	22,0	22,0	3,0	—	44	—	1108	0,2	33,76
TB 20 L 050	20	8F	St	60,64	59,88	66	19,0	22,0	22,0	3,0	—	48	—	1108	0,2	36,48
TB 21 L 050	21	8F	St	63,67	62,91	71	19,0	22,0	22,0	3,0	—	48	—	1108	0,3	36,48
TB 22 L 050	22	8F	St	66,70	65,94	75	19,0	22,0	22,0	3,0	—	51	—	1108	0,3	40,80
TB 23 L 050	23	8F	GG	69,73	68,97	79	19,0	22,0	22,0	3,0	—	54	—	1108	0,4	43,68
TB 24 L 050	24	8F	GG	72,77	72,00	79	19,0	22,0	22,0	3,0	—	54	—	1108	0,4	45,12
TB 25 L 050	25	8F	GG	75,80	75,04	83	19,0	22,0	22,0	3,0	—	56	—	1108	0,5	48,32
TB 26 L 050	26	8F	GG	78,83	78,07	87	19,0	22,0	22,0	3,0	—	60	—	1108	0,5	50,72
TB 27 L 050	27	8F	GG	81,86	81,10	87	19,0	22,0	22,0	3,0	—	65	—	1108	0,6	51,84
TB 28 L 050	28	8F	GG	84,89	84,13	91	19,0	22,0	22,0	3,0	—	65	—	1108	0,6	53,92
TB 30 L 050	30	8F	GG	90,96	90,20	97	19,0	22,0	22,0	3,0	—	70	—	1108	0,8	57,60
TB 32 L 050	32	8F	GG	97,02	96,26	103	19,0	22,0	22,0	3,0	—	74	—	1108	0,9	61,92
TB 36 L 050	36	8F	GG	109,15	108,39	115	19,0	22,0	22,0	3,0	—	87	—	1108	1,2	68,48
TB 40 L 050	40	8F	GG	121,28	120,51	127	19,0	25,0	25,0	6,0	—	97	—	1610	1,5	84,48
TB 48 L 050	48	8WF	GG	145,53	144,77	152	19,0	25,0	25,0	6,0	—	88	124	1610	2,3	108,96
TB 60 L 050	60	7W	GG	181,91	181,15	—	19,0	25,0	25,0	3,0	—	92	166	1610	2,0	128,80
TB 72 L 050	72	7A	GG	218,30	217,53	—	19,0	25,0	25,0	3,0	—	92	202	1610	3,0	150,88
TB 84 L 050	84	7A	GG	254,68	253,90	—	19,0	25,0	25,0	3,0	—	92	236	1610	4,0	177,28
TB 96 L 050	96	7A	GG	291,06	290,30	—	19,0	32,0	32,0	6,5	—	106	270	2012	5,5	232,96
TB 120 L 050	120	7A	GG	363,83	363,07	—	19,0	32,0	32,0	6,5	—	106	343	2012	6,8	300,96

Profil Profile L – Teilung Pitch 9,525 mm für Riemenbreite for belt width 075

TB 18 L 075	18	3F	St	54,57	53,81	60	25,0	25,0	25,0	—	—	—	—	1108	0,2	36,32
TB 19 L 075	19	3F	St	57,61	56,84	60	25,0	25,0	25,0	—	—	—	—	1108	0,3	37,92
TB 20 L 075	20	3F	St	60,64	59,88	66	25,0	25,0	25,0	—	—	—	—	1108	0,3	40,80
TB 21 L 075	21	3F	St	63,67	62,91	71	25,0	25,0	25,0	—	—	—	—	1108	0,4	40,64
TB 22 L 075	22	3F	St	66,70	65,94	75	25,0	25,0	25,0	—	—	—	—	1108	0,4	45,28
TB 23 L 075	23	3F	GG	69,73	68,97	79	25,0	25,0	25,0	—	—	—	—	1108	0,4	48,80
TB 24 L 075	24	3F	GG	72,77	72,00	79	25,0	25,0	25,0	—	—	—	—	1108	0,5	51,20
TB 25 L 075	25	3F	GG	75,80	75,04	83	25,0	25,0	25,0	—	—	—	—	1108	0,6	54,56
TB 26 L 075	26	3F	GG	78,83	78,07	87	25,0	25,0	25,0	—	—	—	—	1108	0,6	56,96
TB 27 L 075	27	3F	GG	81,86	81,10	87	25,0	25,0	25,0	—	—	—	—	1108	0,7	60,80
TB 28 L 075	28	3F	GG	84,89	84,13	91	25,0	25,0	25,0	—	—	—	—	1108	0,7	63,84
TB 30 L 075	30	3F	GG	90,96	90,20	97	25,0	25,0	25,0	—	—	—	—	1108	0,9	66,08
TB 32 L 075	32	3F	GG	97,02	96,26	103	25,0	25,0	25,0	—	—	—	—	1108	1,0	70,88
TB 36 L 075	36	3F	GG	109,15	108,39	115	25,0	25,0	25,0	—	—	—	—	1610	1,2	80,96
TB 40 L 075	40	3F	GG	121,28	120,51	127	25,0	25,0	25,0	—	—	—	—	1610	1,7	93,92
TB 48 L 075	48	3WF	GG	145,53	144,77	152	25,0	25,0	25,0	—	—	92	124	1610	2,5	113,28
TB 60 L 075	60	3W	GG	181,91	181,15	—	25,0	25,0	25,0	—	—	92	166	1610	3,0	136,64
TB 72 L 075	72	3A	GG	218,30	217,53	—	25,0	25,0	25,0	—	—	92	202	1610	4,0	169,76
TB 84 L 075	84	7A	GG	254,68	253,90	—	25,0	32,0	32,0	3,5	—	106	236	2012	5,2	206,08
TB 96 L 075	96	7A	GG	291,06	290,30	—	25,0	32,0	32,0	3,5	—	106	270	2012	6,5	262,08
TB 120 L 075	120	7A	GG	363,83	363,07	—	25,0	32,0	32,0	3,5	—	106	343	2012	7,6	332,64

Taper-Buchse Taper bushing	1108	1610	2012
Bohrung d ₂ (mm) von ... bis ... Bore d ₂ (mm) from ... to ...	10-28	14-42	14-50
Fr./Stück each	12,96	20,80	24,64

St = Stahl Steel
 GG = Grauguss Cast iron
 Fertigungstechnische Änderungen vorbehalten.
 We reserve the right to make technical changes.
 Bohrungsdurchmesser d₂ siehe Seite 3.
 Bore diameters d₂ see page 3.

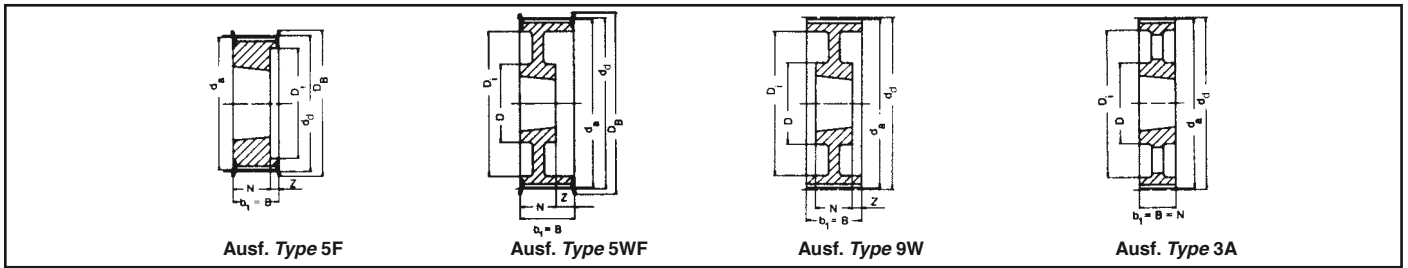

Profil Profile L – Teilung Pitch 9,525 mm für Riemenbreite for belt width 100

Bezeichnung Part No.	Anzahl der Zähne No. of teeth	Aus- füh- rung Type	Mate- rial	d _d (mm)	d _a (mm)	D _B (mm)	b ₁ (mm)	B (mm)	N (mm)	V (mm)	Z (mm)	D (mm)	D ₁ (mm)	Taper- Buchse Taper bushing	Gewicht ohne Buchse Weight without bushing (≈ kg)	Fr. Stück ohne Buchse each without bushing
TB 18 L 100	18	5F	St	54,57	53,81	60	31,0	31,0	22,0	—	9,0	—	38	1108	0,2	39,36
TB 19 L 100	19	5F	St	57,61	56,84	60	31,0	31,0	22,0	—	9,0	—	38	1108	0,3	40,96
TB 20 L 100	20	5F	St	60,64	59,88	66	31,0	31,0	22,0	—	9,0	—	45	1108	0,4	44,48
TB 21 L 100	21	5F	St	63,67	62,91	71	31,0	31,0	22,0	—	9,0	—	47	1108	0,4	44,32
TB 22 L 100	22	5F	St	66,70	65,94	75	31,0	31,0	22,0	—	9,0	—	51	1108	0,4	49,12
TB 23 L 100	23	5F	GG	69,73	68,97	79	32,0	32,0	22,0	—	10,0	—	54	1108	0,5	54,72
TB 24 L 100	24	5F	GG	72,77	72,00	79	32,0	32,0	22,0	—	10,0	—	54	1108	0,6	57,60
TB 25 L 100	25	5F	GG	75,80	75,04	83	32,0	32,0	22,0	—	10,0	—	56	1108	0,6	62,72
TB 26 L 100	26	5F	GG	78,83	78,07	87	32,0	32,0	22,0	—	10,0	—	60	1108	0,7	65,28
TB 27 L 100	27	5F	GG	81,86	81,10	87	32,0	32,0	22,0	—	10,0	—	62	1108	0,8	67,04
TB 28 L 100	28	5F	GG	84,89	84,13	91	32,0	32,0	22,0	—	10,0	—	65	1108	0,8	70,24
TB 30 L 100	30	5F	GG	90,96	90,20	97	32,0	32,0	25,0	—	7,0	—	71	1210	0,9	72,48
TB 32 L 100	32	5F	GG	97,02	96,26	103	32,0	32,0	25,0	—	7,0	—	75	1210	1,0	79,20
TB 36 L 100	36	5F	GG	109,15	108,39	115	32,0	32,0	25,0	—	7,0	—	89	1610	1,4	88,16
TB 40 L 100	40	5F	GG	121,28	120,51	127	32,0	32,0	25,0	—	7,0	—	101	1610	1,7	100,32
TB 48 L 100	48	5WF	GG	145,53	144,77	152	32,0	32,0	25,0	—	7,0	92	124	1610	2,7	130,88
TB 60 L 100	60	9W	GG	181,91	181,15	—	32,0	32,0	25,0	—	3,5	92	166	1610	2,4	154,88
TB 72 L 100	72	3A	GG	218,30	217,53	—	32,0	32,0	32,0	—	—	106	202	2012	4,4	193,92
TB 84 L 100	84	3A	GG	254,68	253,90	—	32,0	32,0	32,0	—	—	106	236	2012	6,0	227,20
TB 96 L 100	96	3A	GG	291,06	290,30	—	32,0	32,0	32,0	—	—	106	270	2012	7,1	289,60
TB 120 L 100	120	3A	GG	363,83	363,07	—	32,0	32,0	32,0	—	—	106	343	2012	8,5	368,64

Taper-Buchse Taper bushing	1108	1210	1610	2012
Bohrung d ₂ (mm) von ... bis ... Bore d ₂ (mm) from ... to ...	10-28	11-32	14-42	14-50
Fr./Stück each	12,96	18,40	20,80	24,64

St = Stahl Steel
 GG = Grauguss Cast iron
 Fertigungstechnische Änderungen vorbehalten.
 We reserve the right to make technical changes.
 Bohrungsdurchmesser d₂ siehe Seite 3.
 Bore diameters d₂ see page 3.

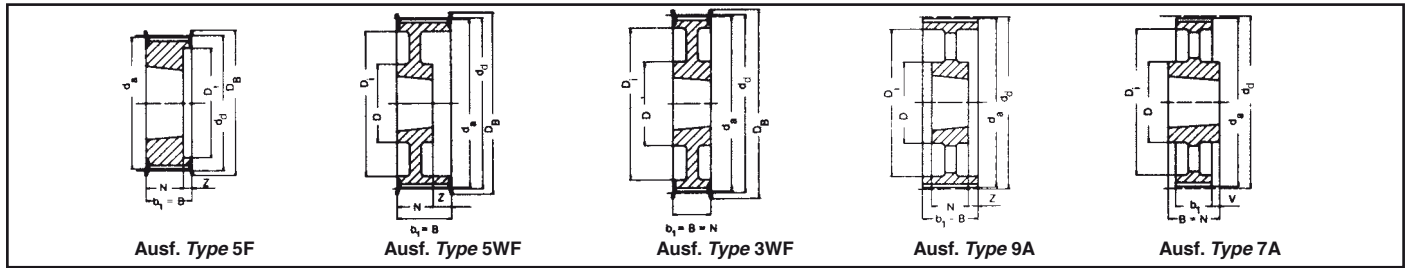

Ausf. Type 5F

Ausf. Type 5WF

Ausf. Type 3WF

Ausf. Type 9A

Ausf. Type 7A

Profil Profile H – Teilung Pitch 12,7 mm für Riemenbreite for belt width 100

Bezeichnung Part No.	Anzahl der Zähne No. of teeth	Aus- füh- rung Type	Mate- rial	d _d (mm)	d _a (mm)	D _B (mm)	b ₁ (mm)	B (mm)	N (mm)	V (mm)	Z (mm)	D (mm)	D _i (mm)	Taper- Buchse Taper bushing	Gewicht ohne Buchse Weight without bushing (≈ kg)	Fr. Stück ohne Buchse each without bushing
TB 16 H 100	16	5F	St	64,68	63,31	71	31,0	31,0	22,0	—	9,0	—	45	1108	0,4	44,32
TB 18 H 100	18	5F	St	72,77	71,39	79	31,0	31,0	25,0	—	6,0	—	52	1210	0,5	50,72
TB 19 H 100	19	5F	St	76,81	75,44	83	31,0	31,0	25,0	—	6,0	—	56	1210	0,6	57,12
TB 20 H 100	20	5F	St	80,55	79,48	87	31,0	31,0	25,0	—	6,0	—	60	1210	0,7	59,68
TB 21 H 100	21	5F	GG	84,89	83,52	91	32,0	32,0	25,0	—	7,0	—	63	1210	0,8	64,00
TB 22 H 100	22	5F	GG	88,94	87,56	93	32,0	32,0	25,0	—	7,0	—	67	1210	0,9	67,20
TB 23 H 100	23	5F	GG	92,98	91,61	97	32,0	32,0	25,0	—	7,0	—	71	1610	0,9	69,44
TB 24 H 100	24	5F	GG	97,02	95,65	103	32,0	32,0	25,0	—	7,0	—	75	1610	1,0	72,64
TB 25 H 100	25	5F	GG	101,06	99,69	106	32,0	32,0	25,0	—	7,0	—	79	1610	1,0	75,84
TB 26 H 100	26	5F	GG	105,11	103,73	111	32,0	32,0	25,0	—	7,0	—	83	1610	1,2	79,84
TB 27 H 100	27	5F	GG	109,15	107,78	115	32,0	32,0	25,0	—	7,0	—	87	1610	1,3	83,68
TB 28 H 100	28	5F	GG	113,19	111,82	119	32,0	32,0	25,0	—	7,0	—	91	1610	1,5	86,88
TB 30 H 100	30	5F	GG	121,28	119,90	127	32,0	32,0	25,0	—	7,0	—	99	1610	1,7	92,80
TB 32 H 100	32	5WF	GG	129,36	127,99	135	32,0	32,0	25,0	—	7,0	92	108	1610	2,0	111,84
TB 36 H 100	36	5WF	GG	145,53	144,16	152	32,0	32,0	25,0	—	7,0	92	124	1610	2,7	126,40
TB 40 H 100	40	5WF	GG	161,70	160,33	168	32,0	32,0	25,0	—	7,0	92	140	1610	3,6	143,84
TB 44 H 100	44	3WF	GG	177,87	176,50	184	32,0	32,0	32,0	—	—	106	153	2012	3,8	161,12
TB 48 H 100	48	3WF	GG	194,04	192,67	200	32,0	32,0	32,0	—	—	106	169	2012	3,2	184,48
TB 60 H 100	60	9A	GG	242,55	241,18	—	34,0	34,0	32,0	—	1,0	106	223	2012	4,8	217,44
TB 72 H 100	72	9A	GG	291,06	289,69	—	34,0	34,0	32,0	—	1,0	106	270	2012	5,7	255,20
TB 84 H 100*	84	9A	GG	339,57	338,20	—	34,0	34,0	32,0	—	1,0	106	318	2012	6,8	310,56
TB 96 H 100*	96	7A	GG	388,08	386,71	—	34,0	45,0	45,0	5,5	—	119	366	2517	8,2	395,04
TB 120 H 100*	120	7A	GG	485,10	483,73	—	34,0	45,0	45,0	5,5	—	119	462	2517	12,1	534,72

Profil Profile H – Teilung Pitch 12,7 mm für Riemenbreite for belt width 150

TB 18 H 150	18	5F	St	72,77	71,39	79	45,0	45,0	25,0	—	20,0	—	53	1210	0,6	61,60
TB 19 H 150	19	5F	St	76,81	75,44	83	45,0	45,0	25,0	—	20,0	—	56	1210	0,7	68,00
TB 20 H 150	20	5F	St	80,55	79,48	87	45,0	45,0	25,0	—	20,0	—	60	1210	0,8	70,40
TB 21 H 150	21	5F	GG	84,89	83,52	91	45,0	45,0	25,0	—	20,0	—	64	1210	1,0	74,56
TB 22 H 150	22	5F	GG	88,94	87,56	93	45,0	45,0	25,0	—	20,0	—	68	1210	1,2	76,80
TB 23 H 150	23	5F	GG	92,98	91,61	97	45,0	45,0	25,0	—	20,0	—	71	1610	1,3	78,72
TB 24 H 150	24	5F	GG	97,02	95,65	103	45,0	45,0	25,0	—	20,0	—	74	1610	1,2	81,44
TB 25 H 150	25	5F	GG	101,06	99,69	106	45,0	45,0	25,0	—	20,0	—	78	1610	1,2	85,60
TB 26 H 150	26	5F	GG	105,11	103,73	111	45,0	45,0	25,0	—	20,0	—	82	1610	1,4	92,48
TB 27 H 150	27	5F	GG	109,15	107,78	115	45,0	45,0	25,0	—	20,0	—	87	1610	1,6	97,76
TB 28 H 150	28	5F	GG	113,19	111,82	119	45,0	45,0	25,0	—	20,0	—	91	1610	1,8	101,60
TB 30 H 150	30	5F	GG	121,28	119,90	127	45,0	45,0	25,0	—	20,0	—	99	1610	2,0	110,40
TB 32 H 150	32	5WF	GG	129,36	127,99	135	45,0	45,0	25,0	—	20,0	92	108	1610	2,3	133,44
TB 36 H 150	36	5WF	GG	145,53	144,16	152	45,0	45,0	25,0	—	20,0	92	124	1610	3,1	156,16
TB 40 H 150	40	5WF	GG	161,70	160,33	168	45,0	45,0	25,0	—	20,0	92	140	1610	4,0	173,92
TB 44 H 150	44	5WF	GG	177,87	176,50	184	45,0	45,0	32,0	—	13,0	106	153	2012	4,4	202,24
TB 48 H 150	48	5WF	GG	194,04	192,67	200	45,0	45,0	32,0	—	13,0	106	169	2012	4,8	223,04
TB 60 H 150	60	9A	GG	242,55	241,18	—	46,0	46,0	32,0	—	7,0	106	223	2012	5,4	240,16
TB 72 H 150	72	9A	GG	291,06	289,69	—	46,0	46,0	32,0	—	7,0	106	270	2012	6,5	276,00
TB 84 H 150*	84	9A	GG	339,57	338,20	—	46,0	46,0	32,0	—	7,0	106	320	2012	8,4	333,92
TB 96 H 150*	96	9A	GG	388,08	386,71	—	46,0	46,0	45,0	—	0,5	119	366	2517	11,0	459,84
TB 120 H 150*	120	9A	GG	485,10	483,73	—	46,0	46,0	45,0	—	0,5	119	462	2517	14,8	573,28

Taper-Buchse Taper bushing	1108	1210	1610	2012	2517
Bohrung d ₂ (mm) von ... bis ... Bore d ₂ (mm) from ... to ...	10-28	11-32	14-42	14-50	16-60
Fr./Stück each	12,96	18,40	20,80	24,64	37,60

St = Stahl *Steel* – GG = Grauguss *Cast iron*
 Fertigungstechnische Änderungen vorbehalten.
 We reserve the right to make technical changes.
 * Keine Lagerware *Non stock items*
 Bohrungsdurchmesser d₂ siehe Seite 3.
 Bore diameters d₂ see page 3.

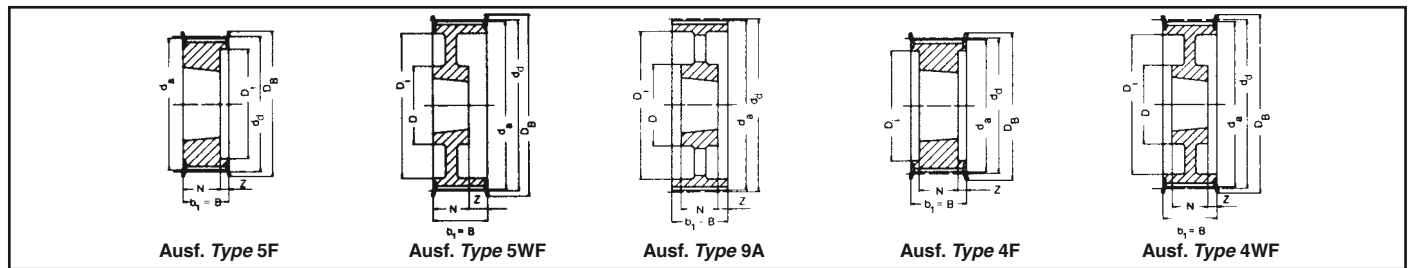

Profil Profile H – Teilung Pitch 12,7 mm für Riemenbreite for belt width 200

Bezeichnung Part No.	Anzahl der Zähne No. of teeth	Aus- füh- rung Type	Mate- rial	d _d (mm)	d _a (mm)	D _B (mm)	b ₁ (mm)	B (mm)	N (mm)	V (mm)	Z (mm)	D (mm)	D ₁ (mm)	Taper- Buchse Taper bushing	Gewicht ohne Buchse Weight without bushing (≈ kg)	Fr. Stück ohne Buchse each without bushing
TB 18 H 200	18	5F	St	72,77	71,39	79	58,0	58,0	25,0	—	33,0	—	52	1210	0,8	67,68
TB 19 H 200	19	5F	St	76,81	75,44	83	58,0	58,0	25,0	—	33,0	—	56	1610	0,9	76,64
TB 20 H 200	20	5F	St	80,55	79,48	87	58,0	58,0	25,0	—	33,0	—	60	1610	1,0	81,28
TB 21 H 200	21	5F	GG	84,89	83,52	91	58,0	58,0	25,0	—	33,0	—	64	1610	1,7	86,08
TB 22 H 200	22	5F	GG	88,94	87,56	93	58,0	58,0	25,0	—	33,0	—	68	1610	1,5	90,08
TB 23 H 200	23	5F	GG	92,98	91,61	97	58,0	58,0	25,0	—	33,0	—	71	1610	1,8	93,12
TB 24 H 200	24	5F	GG	97,02	95,65	103	58,0	58,0	25,0	—	33,0	—	74	1610	1,5	97,12
TB 25 H 200	25	5F	GG	101,06	99,69	106	58,0	58,0	25,0	—	33,0	—	78	1610	1,5	100,32
TB 26 H 200	26	5F	GG	105,11	103,73	111	58,0	58,0	25,0	—	33,0	—	82	1610	1,8	108,32
TB 27 H 200	27	5F	GG	109,15	107,78	115	58,0	58,0	25,0	—	33,0	—	87	1610	1,9	114,40
TB 28 H 200	28	5F	GG	113,19	111,82	119	58,0	58,0	25,0	—	33,0	—	91	1610	1,9	120,32
TB 30 H 200	30	5F	GG	121,28	119,90	127	58,0	58,0	25,0	—	33,0	—	99	1610	2,3	131,68
TB 32 H 200	32	5F	GG	129,36	127,99	135	58,0	58,0	32,0	—	26,0	—	107	2012	3,0	159,68
TB 36 H 200	36	5WF	GG	145,53	144,16	152	58,0	58,0	32,0	—	26,0	102	124	2012	3,0	187,52
TB 40 H 200	40	5WF	GG	161,70	160,33	168	58,0	58,0	32,0	—	26,0	106	140	2012	3,6	217,44
TB 44 H 200	44	5WF	GG	177,87	176,50	184	58,0	58,0	32,0	—	26,0	106	153	2012	4,5	230,72
TB 48 H 200	48	5WF	GG	194,04	192,67	200	58,0	58,0	45,0	—	13,0	119	169	2517	4,6	264,64
TB 60 H 200	60	9A	GG	242,55	241,18	—	60,0	60,0	45,0	—	7,5	119	223	2517	7,0	296,80
TB 72 H 200	72	9A	GG	291,06	289,69	—	60,0	60,0	45,0	—	7,5	119	270	2517	8,0	332,80
TB 84 H 200*	84	9A	GG	339,57	338,20	—	60,0	60,0	45,0	—	7,5	119	320	2517	9,0	388,32
TB 96 H 200*	96	9A	GG	388,08	386,71	—	60,0	60,0	45,0	—	7,5	119	366	2517	11,5	504,32
TB 120 H 200*	120	9A	GG	485,10	483,73	—	60,0	60,0	45,0	—	7,5	119	462	2517	15,4	684,64

Profil Profile H – Teilung Pitch 12,7 mm für Riemenbreite for belt width 300

TB 20 H 300	20	4F	St	80,55	79,48	87	84,0	84,0	38,0	—	23,0	—	65	1615	1,5	109,28
TB 21 H 300	21	4F	GG	84,89	83,52	91	84,0	84,0	38,0	—	23,0	—	66	1615	1,2	114,08
TB 22 H 300	22	4F	GG	88,94	87,56	93	84,0	84,0	38,0	—	23,0	—	67	1615	1,6	116,80
TB 23 H 300	23	4F	GG	92,98	91,61	97	84,0	84,0	38,0	—	23,0	—	71	1615	1,8	118,88
TB 24 H 300	24	4F	GG	97,02	95,65	103	84,0	84,0	38,0	—	23,0	—	75	1615	2,1	123,20
TB 25 H 300	25	4F	GG	101,06	99,69	106	84,0	84,0	38,0	—	23,0	—	79	1615	2,0	128,96
TB 26 H 300	26	4F	GG	105,11	103,73	111	84,0	84,0	38,0	—	23,0	—	83	1615	2,7	138,56
TB 27 H 300	27	4F	GG	109,15	107,78	115	84,0	84,0	32,0	—	26,0	—	87	2012	3,0	147,84
TB 28 H 300	28	4F	GG	113,19	111,82	119	84,0	84,0	32,0	—	26,0	—	91	2012	2,4	154,72
TB 30 H 300	30	4F	GG	121,28	119,90	127	84,0	84,0	32,0	—	26,0	—	99	2012	2,9	167,52
TB 32 H 300	32	4F	GG	129,36	127,99	135	84,0	84,0	45,0	—	19,5	—	107	2517	3,3	206,08
TB 36 H 300	36	4F	GG	145,53	144,16	152	84,0	84,0	45,0	—	19,5	—	124	2517	4,5	235,84
TB 40 H 300	40	4F	GG	161,70	160,33	168	84,0	84,0	45,0	—	19,5	—	137	2517	6,0	264,64
TB 44 H 300	44	4WF	GG	177,87	176,50	184	86,0	86,0	45,0	—	20,5	119	153	2517	6,6	306,24
TB 48 H 300	48	4WF	GG	194,04	192,67	200	86,0	86,0	45,0	—	20,5	119	169	2517	7,6	332,80
TB 60 H 300	60	9A	GG	242,55	241,18	—	86,0	86,0	45,0	—	20,5	119	223	2517	8,4	391,36
TB 72 H 300	72	9A	GG	291,06	289,69	—	86,0	86,0	45,0	—	20,5	119	270	2517	10,4	446,24
TB 84 H 300*	84	9A	GG	339,57	338,20	—	86,0	86,0	45,0	—	20,5	119	320	2517	12,5	549,44
TB 96 H 300*	96	9A	GG	388,08	386,71	—	86,0	86,0	76,0	—	5,0	150	362	3030	14,2	810,24
TB 120 H 300*	120	9A	GG	485,10	483,73	—	86,0	86,0	76,0	—	5,0	150	460	3030	18,8	1.027,04

Taper-Buchse Taper bushing	1210	1610	1615	2012	2517	3030
Bohrung d ₂ (mm) von ... bis ... Bore d ₂ (mm) from ... to ...	11-32	14-42	14-42	14-50	16-60	35-75
Fr./Stück each	18,40	20,80	23,04	24,64	37,60	66,08

St = Stahl Steel – GG = Grauguss Cast iron
 Fertigungstechnische Änderungen vorbehalten.
 We reserve the right to make technical changes.
 * Keine Lagerware Non stock items
 Bohrungsdurchmesser d₂ siehe Seite 3.
 Bore diameters d₂ see page 3.

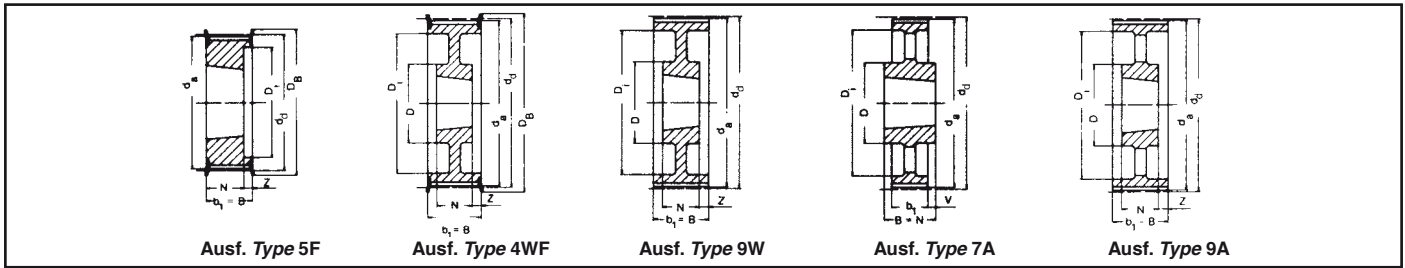

Profil Profile XH – Teilung Pitch 22,225 mm für Riemenbreite for belt width 200

Bezeichnung Part No.	Anzahl der Zähne No. of teeth	Aus- füh- rung Type	Mate- rial	d_d (mm)	d_a (mm)	D_B (mm)	b_1 (mm)	B (mm)	N (mm)	V (mm)	Z (mm)	D (mm)	D_i (mm)	Taper- Buchse Taper bushing	Gewicht ohne Buchse Weight without bushing (≈ kg)	Fr. Stück ohne Buchse each without bushing
TB 18 XH 200*	18	5F	GG	127,34	124,55	138	64	64	45	—	20,0	—	95	2517	2,6	auf Anfrage on request
TB 20 XH 200*	20	5F	GG	141,49	138,69	154	64	64	45	—	20,0	—	110	2517	3,6	
TB 22 XH 200*	22	5F	GG	155,64	152,84	168	64	64	45	—	20,0	—	120	2517	4,8	
TB 24 XH 200*	24	5F	GG	169,79	166,69	183	64	64	45	—	20,0	—	135	2517	6,1	
TB 26 XH 200*	26	5F	GG	183,94	181,14	198	64	64	45	—	20,0	—	150	2517	7,4	
TB 28 XH 200*	28	4WF	GG	198,08	195,29	211	64	64	45	—	10,0	120	165	2517	9,0	
TB 30 XH 200*	30	4WF	GG	212,23	209,44	226	64	64	45	—	10,0	120	180	2517	8,6	
TB 32 XH 200*	32	4WF	GG	226,38	223,59	240	64	64	45	—	10,0	120	195	2517	9,8	
TB 40 XH 200*	40	4WF	GG	282,98	280,18	296	64	64	51	—	6,5	160	245	3020	13,3	
TB 48 XH 200*	48	9W	GG	339,57	336,78	—	64	64	51	—	6,5	160	300	3020	19,0	

Profil Profile XH – Teilung Pitch 22,225 mm für Riemenbreite for belt width 300

TB 18 XH 300*	18	5F	GG	127,34	124,55	138	90	90	45	—	45,0	—	95	2517	3,7	auf Anfrage on request
TB 20 XH 300*	20	5F	GG	141,49	138,69	154	90	90	45	—	45,0	—	110	2517	4,7	
TB 22 XH 300*	22	5F	GG	155,64	152,84	168	90	90	45	—	45,0	—	120	2517	6,0	
TB 24 XH 300*	24	5F	GG	169,79	166,69	183	90	90	45	—	45,0	—	135	2517	7,6	
TB 26 XH 300*	26	5F	GG	183,94	181,14	198	90	90	45	—	45,0	—	150	2517	9,8	
TB 28 XH 300*	28	5F	GG	198,08	195,29	211	90	90	51	—	39,0	—	165	3020	11,6	
TB 30 XH 300*	30	5F	GG	212,23	209,44	226	90	90	51	—	39,0	—	180	3020	11,9	
TB 32 XH 300*	32	5F	GG	226,38	223,59	240	90	90	51	—	39,0	—	195	3020	13,8	
TB 40 XH 300*	40	4WF	GG	282,98	280,18	296	90	90	51	—	19,5	160	245	3020	19,5	
TB 48 XH 300*	48	9W	GG	339,57	336,78	—	90	90	51	—	19,5	160	300	3020	27,0	

Taper-Buchse Taper bushing	2517	3020	3535	4040
Bohrung d_2 (mm) von ... bis ... Bore d_2 (mm) from ... to ...	16-60	25-75	35-90	40-100
Fr./Stück each	37,60	50,24	127,04	178,56

GG = Grauguss Cast iron
Fertigungstechnische Änderungen vorbehalten.
We reserve the right to make technical changes.
* Keine Lagerware Non stock items
Bohrungsdurchmesser d_2 siehe Seite 3.
Bore diameters d_2 see page 3.

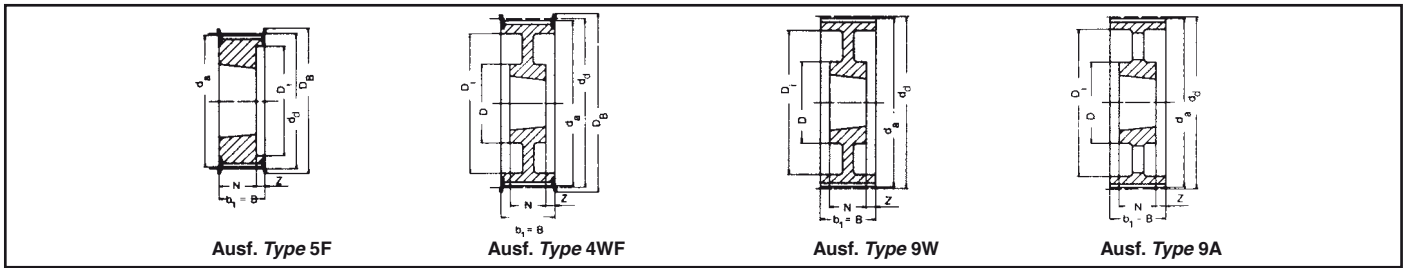

Profil Profile XH – Teilung Pitch 22,225 mm für Riemenbreite for belt width 400

Bezeichnung Part No.	Anzahl der Zähne No. of teeth	Aus- füh- rung Type	Mate- rial	d_d (mm)	d_a (mm)	D_B (mm)	b_1 (mm)	B (mm)	N (mm)	V (mm)	Z (mm)	D (mm)	D_1 (mm)	Taper- Buchse Taper bushing	Gewicht ohne Buchse Weight without bushing (≈ kg)	Fr. Stück ohne Buchse each without bushing
TB 20 XH 400*	20	5F	GG	141,49	138,69	154	119	119	45	—	74,0	—	110	2517	6,0	auf Anfrage on request
TB 22 XH 400*	22	5F	GG	155,64	152,84	168	119	119	45	—	74,0	—	120	2517	7,2	
TB 24 XH 400*	24	5F	GG	169,79	166,69	183	119	119	51	—	68,0	—	135	3020	8,4	
TB 26 XH 400*	26	5F	GG	183,94	181,14	198	119	119	51	—	68,0	—	150	3020	10,3	
TB 28 XH 400*	28	5F	GG	198,08	195,29	211	119	119	51	—	68,0	—	165	3020	12,3	
TB 30 XH 400*	30	5F	GG	212,23	209,44	226	119	119	51	—	68,0	—	180	3020	14,3	
TB 32 XH 400*	32	5F	GG	226,38	223,59	240	119	119	51	—	68,0	—	195	3020	19,9	
TB 40 XH 400*	40	4WF	GG	282,98	280,18	296	119	119	89	—	15,0	190	245	3535	24,6	
TB 48 XH 400*	48	9W	GG	339,57	336,78	—	119	119	89	—	15,0	190	300	3535	30,0	

Taper-Buchse Taper bushing	2517	3020	3535	4040
Bohrung d_2 (mm) von ... bis ... Bore d_2 (mm) from ... to ...	16-60	25-75	35-90	40-100
Fr./Stück each	37,60	50,24	127,04	178,56

GG = Grauguss Cast iron
Fertigungstechnische Änderungen vorbehalten.
We reserve the right to make technical changes.
* Keine Lagerware Non stock items
Bohrungsdurchmesser d_2 siehe Seite 3.
Bore diameters d_2 see page 3.

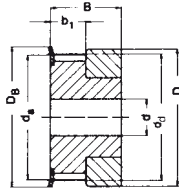

Ausf. Type 1F

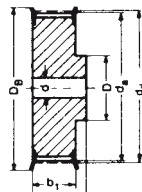

Ausf. Type 6F

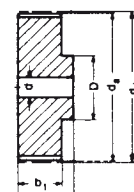

Ausf. Type 6

Profil Profile 3M – Teilung Pitch 3 mm für Riemenbreite for belt width 6 mm Keine Lagerware
 Non stock items

Bezeichnung Part No.	Anzahl der Zähne No. of teeth	Aus- führung Type	Material	d _d (mm)	d _a (mm)	D _B (mm)	b ₁ (mm)	B (mm)	D (mm)	Vor- bohrung Pilot bore d (mm)	Fertig- bohrung Finished bore d _{max} (mm)	Gewicht Weight (≈ kg)	Fr. Stück each
10-3M-6	10	1F	Al	9,55	8,79	13,0	7,2	14,5	13,0	—	3		auf Anfrage on request
12-3M-6	12	1F	Al	11,46	10,70	15,0	7,2	14,5	15,0	—	5		
14-3M-6	14	1F	Al	13,37	12,61	16,0	7,2	14,5	16,0	—	6		
15-3M-6	15	1F	Al	14,32	13,56	17,5	7,2	14,5	17,5	—	6		
16-3M-6	16	6F	Al	15,28	14,52	18,0	9,8	17,5	10,0	4	7		
18-3M-6	18	6F	Al	17,19	16,43	19,5	9,8	17,5	11,0	6	8		
20-3M-6	20	6F	Al	19,10	18,34	23,0	9,8	17,5	13,0	6	9		
21-3M-6	21	6F	Al	20,05	19,29	25,0	9,8	17,5	14,0	6	9		
22-3M-6	22	6F	Al	21,01	20,25	25,0	9,8	17,5	14,0	6	9		
24-3M-6	24	6F	Al	22,92	22,16	25,0	9,8	17,5	14,0	6	9		
26-3M-6	26	6F	Al	24,83	24,07	28,0	9,8	17,5	16,0	6	11		
28-3M-6	28	6F	Al	26,74	25,98	32,0	9,8	17,5	18,0	6	12		
30-3M-6	30	6F	Al	28,65	27,89	32,0	9,8	17,5	20,0	6	14		
32-3M-6	32	6F	Al	30,56	29,80	36,0	9,8	17,5	22,0	6	15		
36-3M-6	36	6F	Al	34,38	33,62	38,0	10,3	18,0	26,0	6	16		
40-3M-6	40	6F	Al	38,20	37,44	42,0	10,3	18,0	28,0	6	18		
44-3M-6	44	6F	Al	42,02	41,26	48,0	10,3	18,0	33,0	6	20		
48-3M-6	48	6	Al	45,84	45,08	—	10,3	18,6	33,0	8	20		
60-3M-6	60	6	Al	57,30	56,54	—	10,3	18,6	33,0	8	20		
72-3M-6	72	6	Al	68,75	67,99	—	10,3	18,6	33,0	8	20		

Profil Profile 3M – Teilung Pitch 3 mm für Riemenbreite for belt width 9 mm

10-3M-9	10	1F	Al	9,55	8,79	13,0	10,2	17,5	13,0	—	3	0,004	15,52
12-3M-9	12	1F	Al	11,46	10,70	15,0	10,2	17,5	15,0	—	5	0,006	16,32
14-3M-9	14	1F	Al	13,37	12,61	16,0	10,2	17,5	16,0	—	6	0,007	16,64
15-3M-9	15	1F	Al	14,32	13,56	17,5	10,2	17,5	17,5	—	6	0,008	17,12
16-3M-9	16	6F	Al	15,28	14,52	18,0	12,8	20,6	10,0	4	7	0,007	18,40
18-3M-9	18	6F	Al	17,19	16,43	19,5	12,8	20,6	11,0	6	8	0,008	19,68
20-3M-9	20	6F	Al	19,10	18,34	23,0	12,8	20,6	13,0	6	9	0,010	21,28
21-3M-9	21	6F	Al	20,05	19,29	25,0	12,8	20,6	14,0	6	9	0,013	21,92
22-3M-9	22	6F	Al	21,01	20,25	25,0	12,8	20,6	14,0	6	9	0,014	23,68
24-3M-9	24	6F	Al	22,92	22,16	25,0	12,8	20,6	14,0	6	9	0,016	24,16
26-3M-9	26	6F	Al	24,83	24,07	28,0	12,8	20,6	16,0	6	11	0,018	25,92
28-3M-9	28	6F	Al	26,74	25,98	32,0	12,8	20,6	18,0	6	12	0,024	27,04
30-3M-9	30	6F	Al	28,65	27,89	32,0	12,8	20,6	20,0	6	14	0,028	28,16
32-3M-9	32	6F	Al	30,56	29,80	36,0	12,8	20,6	22,0	6	15	0,032	29,28
36-3M-9	36	6F	Al	34,38	33,62	38,0	13,4	22,2	26,0	6	16	0,045	32,16
40-3M-9	40	6F	Al	38,20	37,44	42,0	13,4	22,2	28,0	6	18	0,055	32,80
44-3M-9	44	6F	Al	42,02	41,26	48,0	13,4	22,2	33,0	6	20	0,074	39,84
48-3M-9	48	6	Al	45,84	45,08	—	13,4	22,2	33,0	8	20	0,074	42,72
60-3M-9	60	6	Al	57,30	56,54	—	13,4	22,2	33,0	8	20	0,106	51,36
72-3M-9	72	6	Al	68,75	67,99	—	13,4	22,2	33,0	8	20	0,145	64,48

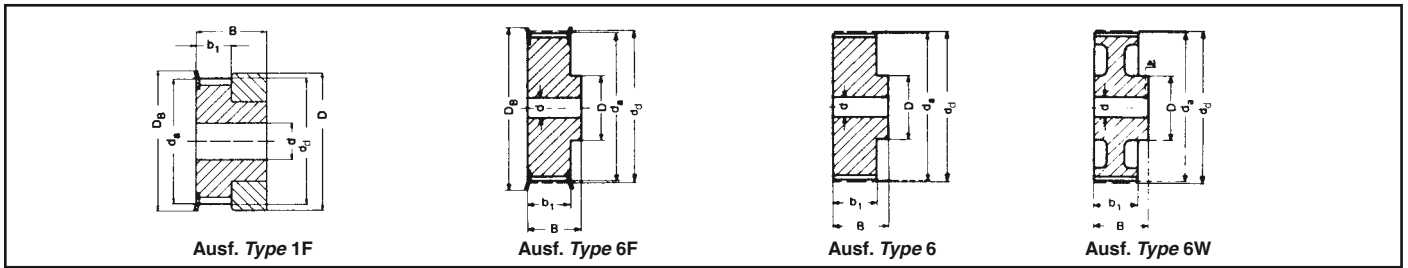

Profil Profile 3M – Teilung Pitch 3 mm für Riemenbreite for belt width 15 mm

Bezeichnung Part No.	Anzahl der Zähne No. of teeth	Aus- führung Type	Material	d _d (mm)	d _a (mm)	D _B (mm)	b ₁ (mm)	B (mm)	D (mm)	Vor- bohrung Pilot bore d (mm)	Fertig- bohrung Finished bore d _{max} (mm)	Gewicht Weight (≈ kg)	Fr. Stück each
10-3M-15	10	1F	Al	9,55	8,79	13,0	17,0	26	13,0	—	3	0,006	17,12
12-3M-15	12	1F	Al	11,46	10,70	15,0	17,0	26	15,0	—	5	0,008	17,92
14-3M-15	14	1F	Al	13,37	12,61	16,0	17,0	26	16,0	—	6	0,010	19,52
15-3M-15	15	1F	Al	14,32	13,56	17,5	17,0	26	17,5	—	6	0,012	20,00
16-3M-15	16	6F	Al	15,28	14,52	18,0	19,5	26	10,0	4	7	0,010	21,28
18-3M-15	18	6F	Al	17,19	16,43	19,5	19,5	26	11,0	6	8	0,012	21,92
20-3M-15	20	6F	Al	19,10	18,34	23,0	19,5	26	13,0	6	9	0,014	22,88
21-3M-15	21	6F	Al	20,05	19,29	25,0	19,5	26	14,0	6	9	0,016	23,68
22-3M-15	22	6F	Al	21,01	20,25	25,0	19,5	26	14,0	6	9	0,018	25,92
24-3M-15	24	6F	Al	22,92	22,16	25,0	19,5	26	14,0	6	9	0,020	27,04
26-3M-15	26	6F	Al	24,83	24,07	28,0	19,5	26	16,0	6	11	0,027	28,16
28-3M-15	28	6F	Al	26,74	25,98	32,0	19,5	26	18,0	6	12	0,030	28,80
30-3M-15	30	6F	Al	28,65	27,89	32,0	19,5	26	20,0	6	14	0,035	31,04
32-3M-15	32	6F	Al	30,56	29,80	36,0	19,5	26	22,0	6	15	0,042	33,44
36-3M-15	36	6F	Al	34,38	33,62	38,0	20,0	30	26,0	6	16	0,060	38,56
40-3M-15	40	6F	Al	38,20	37,44	42,0	20,0	30	28,0	6	18	0,075	39,04
44-3M-15	44	6F	Al	42,02	41,26	48,0	20,0	30	33,0	6	20	0,100	46,08
48-3M-15	48	6	Al	45,84	45,08	—	20,0	30	33,0	8	20	0,103	50,56
60-3M-15	60	6	Al	57,30	56,54	—	20,0	30	33,0	8	20	0,150	62,24
72-3M-15	72	6	Al	68,75	67,99	—	20,0	30	33,0	8	20	0,212	74,72

Profil Profile 5M – Teilung Pitch 5 mm für Riemenbreite for belt width 9 mm

12-5M-9	12	6F	St	19,10	17,96	23	14,5	20,0	13,0	4	7	0,028	16,32
14-5M-9	14	6F	St	22,28	21,14	25	14,5	20,0	14,0	6	8	0,034	16,96
15-5M-9	15	6F	St	23,87	22,73	28	14,5	20,0	16,0	6	10	0,042	17,92
16-5M-9	16	6F	St	25,46	24,32	28	14,5	20,0	16,5	6	10	0,050	19,20
18-5M-9	18	6F	St	28,65	27,51	32	14,5	20,0	20,0	6	12	0,070	21,28
20-5M-9	20	6F	St	31,83	30,69	36	14,5	22,5	23,0	6	14	0,094	22,88
21-5M-9	21	6F	St	33,42	32,28	38	14,5	22,5	24,0	6	14	0,110	24,16
22-5M-9	22	6F	St	35,01	33,87	38	14,5	22,5	25,5	6	14	0,118	25,28
24-5M-9	24	6F	St	38,20	37,06	42	14,5	22,5	27,0	6	16	0,145	26,56
26-5M-9	26	6F	St	41,38	40,24	44	14,5	22,5	30,0	6	18	0,170	27,68
28-5M-9	28	6F	St	44,56	43,42	48	14,5	22,5	30,5	6	18	0,200	28,80
30-5M-9	30	6F	St	47,75	46,61	51	14,5	22,5	35,0	6	20	0,236	30,08
32-5M-9	32	6F	St	50,93	49,79	54	14,5	22,5	38,0	8	22	0,270	32,16
36-5M-9	36	6F	St	57,30	56,16	60	14,5	22,5	38,0	8	22	0,324	35,04
40-5M-9	40	6F	St	63,66	62,52	71	14,5	22,5	38,0	8	22	0,400	36,64
44-5M-9	44	6W	Al	70,03	68,89	—	14,5	25,5	38,0	8	22	0,170	44,64
48-5M-9	48	6W	Al	76,39	75,25	—	14,5	25,5	45,0	8	25	0,182	49,76
60-5M-9	60	6W	Al	95,49	94,35	—	14,5	25,5	45,0	8	25	0,230	69,92
72-5M-9	72	6W	Al	114,59	113,45	—	14,5	25,5	45,0	8	25	0,270	88,64

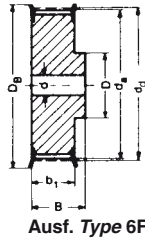

Ausf. Type 6F

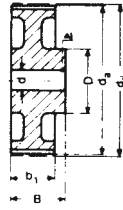

Ausf. Type 6W

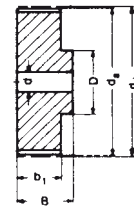

Ausf. Type 6

Profil Profile 5M – Teilung Pitch 5 mm für Riemenbreite for belt width 15 mm

Bezeichnung Part No.	Anzahl der Zähne No. of teeth	Aus- führung Type	Material	d _d (mm)	d _a (mm)	D _B (mm)	b ₁ (mm)	B (mm)	D (mm)	Vor- bohrung Pilot bore d (mm)	Fertig- bohrung Finished bore d _{max} (mm)	Gewicht Weight (≈ kg)	Fr. Stück each
12-5M-15	12	6F	St	19,10	17,96	25	20,5	26	13,0	4	7	0,034	18,56
14-5M-15	14	6F	St	22,28	21,14	25	20,5	26	14,0	6	8	0,046	18,88
15-5M-15	15	6F	St	23,87	22,73	28	20,5	26	16,0	6	10	0,056	20,80
16-5M-15	16	6F	St	25,46	24,32	28	20,5	26	16,5	6	10	0,064	22,40
18-5M-15	18	6F	St	28,65	27,51	32	20,5	26	20,0	6	12	0,086	24,16
20-5M-15	20	6F	St	31,83	30,69	36	20,5	26	23,0	6	14	0,112	25,28
21-5M-15	21	6F	St	33,42	32,28	38	20,5	26	24,0	6	14	0,130	27,04
22-5M-15	22	6F	St	35,01	33,87	38	20,5	26	25,5	6	14	0,140	28,16
24-5M-15	24	6F	St	38,20	37,06	42	20,5	28	27,0	6	16	0,180	30,08
26-5M-15	26	6F	St	41,38	40,24	44	20,5	28	30,0	6	18	0,220	30,56
28-5M-15	28	6F	St	44,56	43,42	48	20,5	28	30,5	6	18	0,250	32,16
30-5M-15	30	6F	St	47,75	46,61	51	20,5	28	35,0	6	20	0,300	35,04
32-5M-15	32	6F	St	50,93	49,79	54	20,5	28	38,0	8	22	0,350	37,92
36-5M-15	36	6F	St	57,30	56,16	60	20,5	28	38,0	8	22	0,426	40,32
40-5M-15	40	6F	St	63,66	62,52	71	20,5	28	38,0	8	22	0,520	43,20
44-5M-15	44	6W	Al	70,03	68,89	—	20,5	30	38,0	8	22	0,225	51,68
48-5M-15	48	6W	Al	76,39	75,25	—	20,5	30	38,0	8	25	0,187	59,68
60-5M-15	60	6W	Al	95,49	94,35	—	20,5	30	50,0	8	25	0,305	81,92
72-5M-15	72	6W	Al	114,59	113,45	—	20,5	30	50,0	8	25	0,375	104,00

Profil Profile 5M – Teilung Pitch 5 mm für Riemenbreite for belt width 25 mm

12-5M-25	12	6F	St	19,10	17,96	25	30	36	13,0	4	7	0,050	23,20
14-5M-25	14	6F	St	22,28	21,14	25	30	36	14,0	6	8	0,070	23,84
15-5M-25	15	6F	St	23,87	22,73	28	30	36	16,0	6	10	0,080	25,92
16-5M-25	16	6F	St	25,46	24,32	28	30	36	16,5	6	10	0,100	27,04
18-5M-25	18	6F	St	28,65	27,51	32	30	36	20,0	6	12	0,120	28,80
20-5M-25	20	6F	St	31,83	30,69	36	30	36	23,0	6	14	0,160	30,08
21-5M-25	21	6F	St	33,42	32,28	38	30	38	24,0	6	14	0,190	31,68
22-5M-25	22	6F	St	35,01	33,87	38	30	38	25,5	6	14	0,210	33,44
24-5M-25	24	6F	St	38,20	37,06	42	30	38	27,0	6	16	0,250	36,16
26-5M-25	26	6F	St	41,38	40,24	44	30	38	30,0	6	18	0,300	39,04
28-5M-25	28	6F	St	44,56	43,42	48	30	38	30,5	6	18	0,350	41,44
30-5M-25	30	6F	St	47,75	46,61	51	30	38	35,0	6	20	0,420	45,60
32-5M-25	32	6F	St	50,93	49,79	54	30	38	38,0	8	22	0,480	48,96
36-5M-25	36	6F	St	57,30	56,16	60	30	38	38,0	8	22	0,590	51,84
40-5M-25	40	6F	St	63,66	62,52	71	30	38	38,0	8	22	0,740	59,36
44-5M-25	44	6W	Al	70,03	68,89	—	30	40	38,0	8	22	0,320	72,80
48-5M-25	48	6W	Al	76,39	75,25	—	30	40	38,0	8	25	0,275	81,28
60-5M-25	60	6W	Al	95,49	94,35	—	30	40	50,0	8	25	0,435	113,12
72-5M-25	72	6W	Al	114,59	113,45	—	30	40	50,0	8	25	0,525	142,40

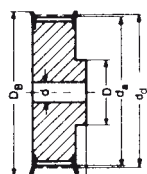

Ausf. Type 6F

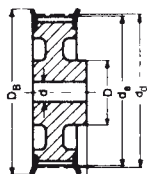

Ausf. Type 6WF

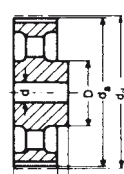

Ausf. Type 6A

Profil Profile 8M – Teilung Pitch 8 mm für Riemenbreite for belt width 20 mm

Bezeichnung Part No.	Anzahl der Zähne No. of teeth	Aus- führung Type	Material	d _d (mm)	d _a (mm)	D _B (mm)	b ₁ (mm)	B (mm)	D (mm)	D _i (mm)	Vor- bohrung Pilot bore d (mm)	Fertig- bohrung Finished bore d _{max} (mm)	Gewicht Weight (≈ kg)	Fr. Stück each
22-8M-20	22	6F	St	56,02	54,65	60,0	28	38	43	—	12	30	0,54	38,56
24-8M-20	24	6F	St	61,12	59,75	66,0	28	38	45	—	12	30	0,65	42,40
26-8M-20	26	6F	St	66,21	64,84	71,0	28	38	50	—	12	35	0,80	46,40
28-8M-20	28	6F	St	71,30	69,93	75,0	28	38	50	—	15	35	0,87	49,76
30-8M-20	30	6F	St	76,39	75,02	83,0	28	38	55	—	15	35	1,02	52,80
32-8M-20	32	6F	St	81,49	80,12	87,0	28	38	60	—	15	40	1,20	57,12
34-8M-20	34	6F	St	86,58	85,22	91,0	28	38	70	—	15	45	1,40	62,72
36-8M-20	36	6F	St	91,67	90,30	98,5	28	38	70	—	15	45	1,55	69,12
38-8M-20	38	6F	St	96,77	95,39	103,0	28	38	75	—	15	45	1,65	75,84
40-8M-20	40	6F	GG	101,86	100,49	106,0	28	38	75	—	15	45	1,80	82,40
44-8M-20	44	6F	GG	112,05	110,67	119,0	28	38	75	—	15	45	2,10	96,64
48-8M-20	48	6F	GG	122,23	120,86	127,0	28	38	75	—	15	45	2,44	107,68
56-8M-20	56	6WF	GG	142,60	141,23	148,0	28	38	80	117	15	45	2,60	139,52
64-8M-20	64	6WF	GG	162,97	161,60	168,0	28	38	80	137	15	45	2,90	164,00
72-8M-20	72	6WF	GG	183,35	181,97	192,0	28	38	80	158	15	45	3,10	187,84
80-8M-20	80	6A	GG	203,72	202,35	—	28	38	90	180	15	50	3,80	198,72
90-8M-20	90	6A	GG	229,18	227,81	—	28	38	90	204	15	50	4,20	222,88
112-8M-20	112	6A	GG	285,21	283,83	—	28	38	90	260	18	50	5,20	289,60
144-8M-20	144	6A	GG	366,69	365,32	—	28	38	90	341	20	50	7,50	389,92
168-8M-20	168	6A	GG	427,81	426,44	—	28	38	100	402	20	55	10,00	590,40
192-8M-20	192	6A	GG	488,92	487,55	—	28	38	100	463	20	55	14,40	712,96

Profil Profile 8M – Teilung Pitch 8 mm für Riemenbreite for belt width 30 mm

22-8M-30	22	6F	St	56,02	54,65	60,0	38	48	43	—	12	30	0,69	44,32
24-8M-30	24	6F	St	61,12	59,75	66,0	38	48	45	—	12	30	0,84	48,16
26-8M-30	26	6F	St	66,21	64,84	71,0	38	48	50	—	12	35	1,00	52,80
28-8M-30	28	6F	St	71,30	69,93	75,0	38	48	50	—	15	35	1,12	58,40
30-8M-30	30	6F	St	76,39	75,02	83,0	38	48	55	—	15	35	1,32	63,20
32-8M-30	32	6F	St	81,49	80,12	87,0	38	48	60	—	15	40	1,50	66,08
34-8M-30	34	6F	St	86,58	85,22	91,0	38	48	70	—	15	45	1,80	71,84
36-8M-30	36	6F	St	91,67	90,30	98,5	38	48	70	—	15	45	1,99	80,80
38-8M-30	38	6F	St	96,77	95,39	103,0	38	48	75	—	15	45	2,27	88,48
40-8M-30	40	6F	GG	101,86	100,49	106,0	38	48	75	—	15	45	2,40	96,64
44-8M-30	44	6F	GG	112,05	110,67	119,0	38	48	75	—	15	45	2,80	110,40
48-8M-30	48	6F	GG	122,23	120,86	127,0	38	48	75	—	15	45	3,20	125,28
56-8M-30	56	6WF	GG	142,60	141,23	148,0	38	48	90	117	15	50	3,60	166,08
64-8M-30	64	6WF	GG	162,97	161,60	168,0	38	48	90	137	15	50	4,30	189,60
72-8M-30	72	6WF	GG	183,35	181,97	192,0	38	48	95	158	15	50	4,80	213,28
80-8M-30	80	6A	GG	203,72	202,35	—	38	48	100	180	15	55	5,10	246,08
90-8M-30	90	6A	GG	229,18	227,81	—	38	48	100	204	15	55	5,70	261,60
112-8M-30	112	6A	GG	285,21	283,83	—	38	48	100	260	18	55	6,80	298,40
144-8M-30	144	6A	GG	366,69	365,32	—	38	48	100	341	20	55	9,30	397,28
168-8M-30	168	6A	GG	427,81	426,44	—	38	48	100	402	20	55	11,40	597,92
192-8M-30	192	6A	GG	488,92	487,55	—	38	48	100	463	20	55	16,00	726,08

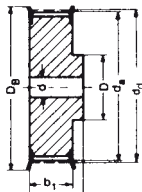

Ausf. Type 6F

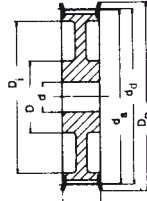

Ausf. Type 10WF



Ausf. Type 10A

Profil Profile 8M – Teilung Pitch 8 mm für Riemenbreite for belt width 50 mm

Bezeichnung Part No.	Anzahl der Zähne No. of teeth	Aus- führung Type	Material	d _d (mm)	d _a (mm)	D _B (mm)	b ₁ (mm)	B (mm)	D (mm)	D _i (mm)	Vor- bohrung Pilot bore d (mm)	Fertig- bohrung Finished bore d _{max} (mm)	Gewicht Weight (≈ kg)	Fr. Stück each
22-8M-50	22	6F	St	56,02	54,65	60,0	60	70	43	—	12	30	1,00	58,24
24-8M-50	24	6F	St	61,12	59,75	66,0	60	70	45	—	12	30	1,20	61,60
26-8M-50	26	6F	St	66,21	64,84	71,0	60	70	50	—	12	35	1,50	68,96
28-8M-50	28	6F	St	71,30	69,93	75,0	60	70	50	—	15	35	1,67	77,12
30-8M-50	30	6F	St	76,39	75,02	83,0	60	70	55	—	15	35	1,97	80,80
32-8M-50	32	6F	St	81,49	80,12	87,0	60	70	60	—	15	40	2,27	87,20
34-8M-50	34	6F	St	86,58	85,22	91,0	60	70	70	—	15	45	2,69	94,72
36-8M-50	36	6F	St	91,67	90,30	98,5	60	70	70	—	15	45	2,97	106,88
38-8M-50	38	6F	St	96,77	95,39	103,0	60	70	75	—	15	45	3,23	117,60
40-8M-50	40	6F	GG	101,86	100,49	106,0	60	70	75	—	18	45	3,50	122,88
44-8M-50	44	6F	GG	112,05	110,67	119,0	60	70	75	—	18	45	3,90	143,36
48-8M-50	48	6F	GG	122,23	120,86	127,0	60	70	80	—	18	45	4,30	164,64
56-8M-50	56	10WF	GG	142,60	141,23	148,0	60	60	90	117	18	50	5,00	202,24
64-8M-50	64	10WF	GG	162,97	161,60	168,0	60	60	100	137	18	55	5,60	236,16
72-8M-50	72	10WF	GG	183,35	181,97	192,0	60	60	100	158	18	55	6,80	255,20
80-8M-50	80	10A	GG	203,72	202,35	—	60	60	110	180	18	60	6,90	304,48
90-8M-50	90	10A	GG	229,18	227,81	—	60	60	110	204	18	60	8,60	342,40
112-8M-50	112	10A	GG	285,21	283,83	—	60	60	110	260	18	60	9,60	391,84
144-8M-50	144	10A	GG	366,69	365,32	—	60	60	110	341	20	60	13,80	567,20
168-8M-50	168	10A	GG	427,81	426,44	—	60	60	120	402	20	65	16,00	776,96
192-8M-50	192	10A	GG	488,92	487,55	—	60	60	130	463	20	70	22,40	994,40

Profil Profile 8M – Teilung Pitch 8 mm für Riemenbreite for belt width 85 mm

22-8M-85	22	6F	St	56,02	54,65	60,0	95	105	43	—	12	30	1,55	74,08
24-8M-85	24	6F	St	61,12	59,75	66,0	95	105	45	—	12	30	1,90	82,24
26-8M-85	26	6F	St	66,21	64,84	71,0	95	105	50	—	12	35	2,25	90,24
28-8M-85	28	6F	St	71,30	69,93	75,0	95	105	50	—	15	35	2,55	104,96
30-8M-85	30	6F	St	76,39	75,02	83,0	95	105	55	—	15	35	3,00	112,32
32-8M-85	32	6F	St	81,49	80,12	87,0	95	105	60	—	15	40	3,57	116,64
34-8M-85	34	6F	St	86,58	85,22	91,0	95	105	70	—	15	45	4,00	130,24
36-8M-85	36	6F	St	91,67	90,30	98,5	95	105	70	—	15	45	4,50	154,24
38-8M-85	38	6F	St	96,77	95,39	103,0	95	105	75	—	15	45	4,90	160,96
40-8M-85	40	6F	GG	101,86	100,49	106,0	95	105	75	—	18	45	5,20	177,28
44-8M-85	44	6F	GG	112,05	110,67	119,0	95	105	75	—	18	45	6,60	198,40
48-8M-85	48	6F	GG	122,23	120,86	127,0	95	105	80	—	18	45	7,60	230,88
56-8M-85	56	6F	GG	142,60	141,23	148,0	95	105	80	—	20	50	9,80	280,96
64-8M-85	64	10WF	GG	162,97	161,60	168,0	95	95	100	137	20	55	10,40	332,80
72-8M-85	72	10WF	GG	183,35	181,97	192,0	95	95	110	158	20	60	11,40	390,08
80-8M-85	80	10A	GG	203,72	202,35	—	95	95	110	180	20	60	11,10	417,44
90-8M-85	90	10A	GG	229,18	227,81	—	95	95	110	204	20	60	13,20	470,40
112-8M-85	112	10A	GG	285,21	283,83	—	95	95	110	260	24	60	16,30	612,48
144-8M-85*	144	10A	GG	366,69	365,32	—	95	95	120	341	24	65	21,50	968,00
168-8M-85*	168	10A	GG	427,81	426,44	—	95	95	120	402	24	65	26,10	1.055,36
192-8M-85*	192	10A	GG	488,92	487,55	—	95	95	130	463	24	70	30,60	1.333,44

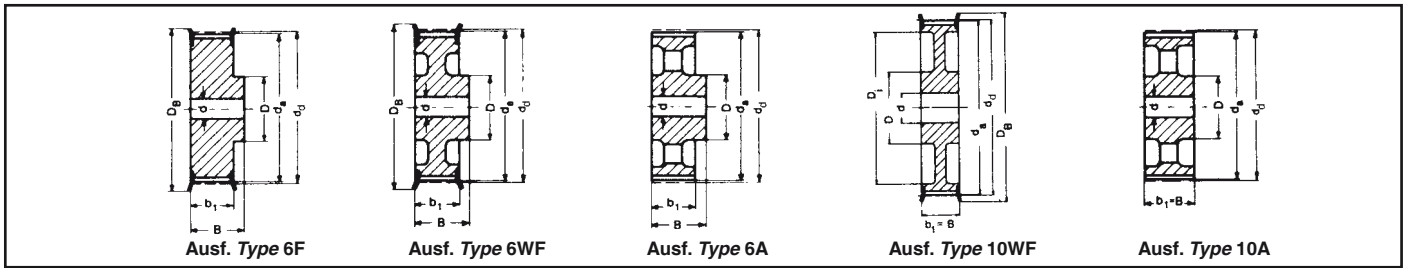

Profil Profile 14M – Teilung Pitch 14 mm für Riemenbreite for belt width 40 mm

Bezeichnung Part No.	Anzahl der Zähne No. of teeth	Aus- führung Type	Material	d _d (mm)	d _a (mm)	D _B (mm)	b ₁ (mm)	B (mm)	D (mm)	D _i (mm)	Vor- bohrung Pilot bore d (mm)	Fertig- bohrung Finished bore d _{max} (mm)	Gewicht Weight (≈ kg)	Fr. Stück each
28-14M-40	28	6F	GG	124,78	122,12	127	54	69	100	—	24	60	4,73	185,92
29-14M-40	29	6F	GG	129,23	126,57	138	54	69	100	—	24	60	5,09	201,92
30-14M-40	30	6F	GG	133,69	130,99	138	54	69	100	—	24	60	5,45	215,52
32-14M-40	32	6F	GG	142,60	139,88	154	54	69	100	—	24	70	6,17	231,04
34-14M-40	34	6F	GG	151,52	148,79	160	54	69	100	—	24	70	6,88	256,16
36-14M-40	36	6F	GG	160,43	157,68	168	54	69	100	—	24	70	7,60	279,52
38-14M-40	38	6F	GG	169,34	166,60	183	54	69	120	—	24	70	8,28	285,44
40-14M-40	40	6F	GG	178,25	175,49	188	54	69	120	—	24	70	9,26	322,24
44-14M-40	44	6F	GG	196,08	193,28	211	54	69	120	—	24	70	10,32	349,44
48-14M-40	48	6WF	GG	213,90	211,11	226	54	69	135	172	24	70	11,50	415,36
56-14M-40	56	6WF	GG	249,55	246,76	256	54	69	135	207	28	70	13,05	475,68
64-14M-40	64	6WF	GG	285,21	282,41	296	54	69	135	242	28	70	14,40	568,80
72-14M-40	72	6A	GG	320,86	318,06	—	54	69	135	278	28	70	16,90	588,16
80-14M-40	80	6A	GG	356,51	353,71	—	54	69	135	314	28	70	18,50	603,68
90-14M-40	90	6A	GG	401,07	398,28	—	54	69	135	358	28	70	20,00	679,36
112-14M-40*	112	6A	GG	499,11	496,32	—	54	69	135	456	28	70	26,70	834,72
144-14M-40*	144	6A	GG	641,71	638,92	—	54	69	135	600	28	70	35,00	1.278,72
168-14M-40*	168	6A	GG	748,66	745,87	—	54	69	135	706	28	70	44,20	1.681,12
192-14M-40*	192	6A	GG	855,62	852,82	—	54	69	135	813	28	70	52,20	2.155,20
216-14M-40*	216	6A	GG	962,57	959,77	—	54	69	150	920	28	80	60,00	2.529,92

Profil Profile 14M – Teilung Pitch 14 mm für Riemenbreite for belt width 55 mm

28-14M-55	28	6F	GG	124,78	122,12	127	70	85	100	—	24	60	5,60	224,80
29-14M-55	29	6F	GG	129,23	126,57	138	70	85	100	—	24	60	6,10	244,64
30-14M-55	30	6F	GG	133,69	130,99	138	70	85	100	—	24	60	6,60	254,24
32-14M-55	32	6F	GG	142,60	139,88	154	70	85	100	—	24	70	7,60	271,84
34-14M-55	34	6F	GG	151,52	148,79	160	70	85	100	—	24	70	8,60	289,28
36-14M-55	36	6F	GG	160,43	157,68	168	70	85	100	—	24	70	9,60	318,40
38-14M-55	38	6F	GG	169,34	166,60	183	70	85	120	—	24	70	10,80	341,60
40-14M-55	40	6F	GG	178,25	175,49	188	70	85	120	—	24	70	11,20	368,80
44-14M-55	44	6F	GG	196,08	193,28	211	70	85	120	—	24	70	12,50	401,76
48-14M-55	48	10WF	GG	213,90	211,11	226	70	70	135	172	24	70	13,70	483,36
56-14M-55	56	10WF	GG	249,55	246,76	256	70	70	135	207	28	70	14,50	547,36
64-14M-55	64	10WF	GG	285,21	282,41	296	70	70	135	242	28	70	15,60	644,48
72-14M-55	72	10A	GG	320,86	318,06	—	70	70	135	278	28	70	18,50	661,92
80-14M-55	80	10A	GG	356,51	353,71	—	70	70	135	314	28	70	20,00	722,08
90-14M-55	90	10A	GG	401,07	398,28	—	70	70	135	358	28	70	22,60	817,28
112-14M-55*	112	10A	GG	499,11	496,32	—	70	70	135	456	28	70	29,50	1.007,52
144-14M-55*	144	10A	GG	641,71	638,92	—	70	70	135	600	28	70	39,00	1.553,60
168-14M-55*	168	10A	GG	748,66	745,87	—	70	70	135	706	28	70	48,50	2.017,76
192-14M-55*	192	10A	GG	855,62	852,82	—	70	70	135	813	28	70	57,80	2.408,16
216-14M-55*	216	10A	GG	962,57	959,77	—	70	70	150	920	28	80	67,00	2.987,84

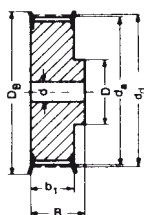

Ausf. Type 6F

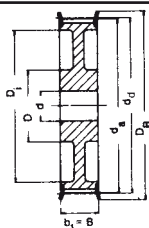

Ausf. Type 10WF

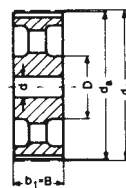

Ausf. Type 10A

Profil Profile 14M – Teilung Pitch 14 mm für Riemenbreite for belt width 85 mm

Bezeichnung Part No.	Anzahl der Zähne No. of teeth	Aus- führung Type	Material	d _d (mm)	d _a (mm)	D _B (mm)	b ₁ (mm)	B (mm)	D (mm)	D _i (mm)	Vor- bohrung Pilot bore d (mm)	Fertig- bohrung Finished bore d _{max} (mm)	Gewicht Weight (≈ kg)	Fr. Stück each
28-14M-85	28	6F	GG	124,78	122,12	127	102	117	100	—	24	60	7,70	285,44
29-14M-85	29	6F	GG	129,23	126,57	138	102	117	100	—	24	60	8,40	302,88
30-14M-85	30	6F	GG	133,69	130,99	138	102	117	100	—	24	60	9,10	310,56
32-14M-85	32	6F	GG	142,60	139,88	154	102	117	100	—	24	60	10,50	345,60
34-14M-85	34	6F	GG	151,52	148,79	160	102	117	100	—	24	70	11,90	388,32
36-14M-85	36	6F	GG	160,43	157,68	168	102	117	100	—	32	70	13,20	423,20
38-14M-85	38	6F	GG	169,34	166,60	183	102	117	120	—	32	70	15,15	458,08
40-14M-85	40	6F	GG	178,25	175,49	188	102	117	135	—	32	70	17,10	493,12
44-14M-85	44	6F	GG	196,08	193,28	211	102	117	135	—	32	70	23,30	568,80
48-14M-85	48	6F	GG	213,90	211,11	226	102	117	150	—	32	80	25,00	642,56
56-14M-85	56	10WF	GG	249,55	246,76	256	102	102	150	207	32	80	25,00	749,28
64-14M-85	64	10WF	GG	285,21	282,41	296	102	102	150	242	32	80	28,20	871,68
72-14M-85	72	10A	GG	320,86	318,06	—	102	102	150	278	32	80	28,80	894,88
80-14M-85	80	10A	GG	356,51	353,71	—	102	102	150	314	32	80	30,10	984,16
90-14M-85	90	10A	GG	401,07	398,28	—	102	102	150	358	32	80	33,00	1.096,80
112-14M-85*	112	10A	GG	499,11	496,32	—	102	102	150	456	32	80	41,80	1.349,12
144-14M-85*	144	10A	GG	641,71	638,92	—	102	102	150	600	32	80	52,40	1.979,84
168-14M-85*	168	10A	GG	748,66	745,87	—	102	102	150	706	32	80	60,30	2.643,20
192-14M-85*	192	10A	GG	855,62	852,82	—	102	102	165	813	32	90	70,20	3.145,12
216-14M-85*	216	10A	GG	962,57	959,77	—	102	102	165	920	32	90	81,00	3.935,68

Profil Profile 14M – Teilung Pitch 14 mm für Riemenbreite for belt width 115 mm

28-14M-115	28	6F	GG	124,78	122,12	127	133	148	100	—	32	60	9,20	359,20
29-14M-115	29	6F	GG	129,23	126,57	138	133	148	100	—	32	60	10,20	386,24
30-14M-115	30	6F	GG	133,69	130,99	138	133	148	100	—	32	60	11,20	401,76
32-14M-115	32	6F	GG	142,60	139,88	154	133	148	100	—	32	60	13,20	434,88
34-14M-115	34	6F	GG	151,52	148,79	160	133	148	100	—	32	70	14,80	493,12
36-14M-115	36	6F	GG	160,43	157,68	168	133	148	120	—	32	70	16,60	549,44
38-14M-115	38	6F	GG	169,34	166,60	183	133	148	120	—	32	70	19,20	588,16
40-14M-115	40	6F	GG	178,25	175,49	188	133	148	135	—	32	70	22,10	621,12
44-14M-115	44	6F	GG	196,08	193,28	211	133	148	140	—	32	80	28,00	722,08
48-14M-115	48	6F	GG	213,90	211,11	226	133	148	150	—	32	80	35,00	801,76
56-14M-115	56	6F	GG	249,55	246,76	256	133	148	150	—	32	80	44,20	972,48
64-14M-115	64	10WF	GG	285,21	282,41	296	133	133	150	242	32	80	36,80	1.106,56
72-14M-115	72	10A	GG	320,86	318,06	—	133	133	150	278	32	80	36,10	1.211,36
80-14M-115	80	10A	GG	356,51	353,71	—	133	133	150	314	32	80	38,60	1.349,12
90-14M-115	90	10A	GG	401,07	398,28	—	133	133	150	358	32	80	41,00	1.529,60
112-14M-115*	112	10A	GG	499,11	496,32	—	133	133	150	456	32	80	54,40	1.848,00
144-14M-115*	144	10A	GG	641,71	638,92	—	133	133	165	600	32	90	67,80	2.834,40
168-14M-115*	168	10A	GG	748,66	745,87	—	133	133	165	706	32	90	75,80	3.264,64
192-14M-115*	192	10A	GG	855,62	852,82	—	133	133	165	813	32	90	88,30	3.846,24
216-14M-115*	216	10A	GG	962,57	959,77	—	133	133	165	920	32	90	98,00	4.606,24

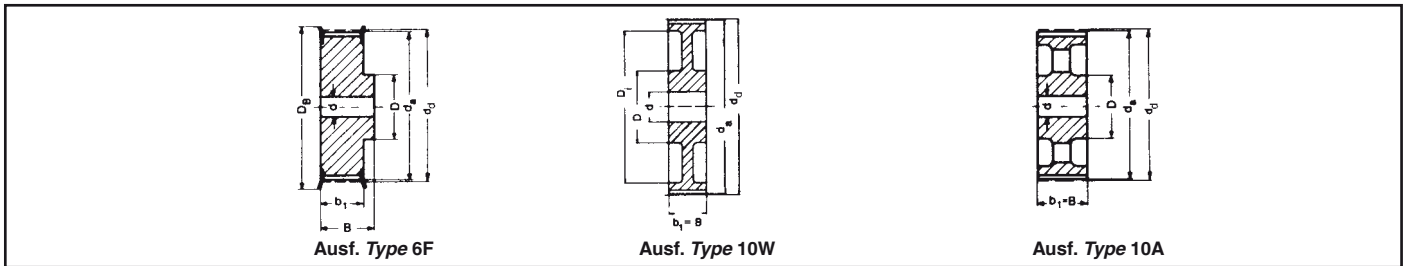

Profil Profile 14M – Teilung Pitch 14 mm für Riemenbreite for belt width 170 mm

Bezeichnung Part No.	Anzahl der Zähne No. of teeth	Aus- führung Type	Material	d _d (mm)	d _a (mm)	D _B (mm)	b ₁ (mm)	B (mm)	D (mm)	D _i (mm)	Vor- bohrung Pilot bore d (mm)	Fertig- bohrung Finished bore d _{max} (mm)	Gewicht Weight (≈ kg)	Fr. Stück each
28-14M-170*	28	6F	GG	124,78	122,12	127	187	202	100	—	32	60	13,80	462,08
29-14M-170*	29	6F	GG	129,23	126,57	138	187	202	100	—	32	60	14,20	520,32
30-14M-170*	30	6F	GG	133,69	130,99	138	187	202	100	—	32	60	15,60	529,92
32-14M-170*	32	6F	GG	142,60	139,88	154	187	202	100	—	32	60	18,10	597,92
34-14M-170*	34	6F	GG	151,52	148,79	160	187	202	100	—	32	60	20,40	706,56
36-14M-170*	36	6F	GG	160,43	157,68	168	187	202	120	—	32	70	23,50	778,40
38-14M-170*	38	6F	GG	169,34	166,60	183	187	202	135	—	32	70	26,50	817,28
40-14M-170*	40	6F	GG	178,25	175,49	188	187	202	140	—	32	85	30,10	871,68
44-14M-170*	44	6F	GG	196,08	193,28	211	187	202	160	—	32	85	37,80	953,12
48-14M-170*	48	6F	GG	213,90	211,11	226	187	202	160	—	32	85	44,50	1.143,36
56-14M-170*	56	6F	GG	249,55	246,76	256	187	202	160	—	32	85	61,00	1.424,80
64-14M-170*	64	6F	GG	285,21	282,41	296	187	202	180	—	32	100	81,00	1.564,64
72-14M-170*	72	10W	GG	320,86	318,06	—	187	187	180	278	32	100	61,40	1.663,68
80-14M-170*	80	10W	GG	356,51	353,71	—	187	187	180	314	32	100	65,00	2.065,44
90-14M-170*	90	10A	GG	401,07	398,28	—	187	187	180	358	38	100	68,00	2.306,08
112-14M-170*	112	10A	GG	499,11	496,32	—	187	187	200	456	38	110	87,50	2.799,20
144-14M-170*	144	10A	GG	641,71	638,92	—	187	187	220	600	38	120	114,80	3.611,20
168-14M-170*	168	10A	GG	748,66	745,87	—	187	187	220	706	38	120	125,00	4.300,32
192-14M-170*	192	10A	GG	855,62	852,82	—	187	187	220	813	38	120	136,40	4.732,64
216-14M-170*	216	10A	GG	962,57	959,77	—	187	187	220	920	38	120	147,00	6.088,96

HTD®-Zahnscheiben Type 20M auf Anfrage
HTD® pulleys profile 20M on request

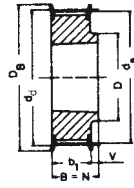

Ausf. Type 8F

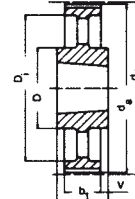

Ausf. Type 7A

Profil Profile 5M – Teilung Pitch 5 mm für Riemenbreite for belt width 15 mm

Bezeichnung Part No.	Anzahl der Zähne No. of teeth	Aus- füh- rung Type	Mate- rial	d _d (mm)	d _a (mm)	D _B (mm)	b ₁ (mm)	B (mm)	N (mm)	V (mm)	Z (mm)	D (mm)	D _i (mm)	Taper- Buchse Taper bushing	Gewicht ohne Buchse Weight without bushing (≈ kg)	Fr. Stück ohne Buchse each without bushing
TB 34-5M-15	34	8F	St	54,11	52,97	57,0	20,5	22	22	1,5	—	43	—	1008	0,190	52,16
TB 36-5M-15	36	8F	St	57,30	56,16	60,0	20,5	22	22	1,5	—	44	—	1108	0,200	53,76
TB 38-5M-15	38	8F	St	69,48	59,34	66,0	20,5	22	22	1,5	—	48	—	1108	0,250	57,60
TB 40-5M-15	40	8F	St	63,66	62,52	71,0	20,5	22	22	1,5	—	52	—	1108	0,310	61,92
TB 44-5M-15	44	8F	St	70,03	68,89	75,0	20,5	22	22	1,5	—	54	—	1108	0,400	67,36
TB 48-5M-15	48	8F	St	76,39	75,25	83,0	20,5	25	25	4,5	—	64	—	1210	0,450	76,64
TB 56-5M-15	56	8F	GG	89,13	87,99	93,0	20,5	25	25	4,5	—	70	—	1210	0,670	83,68
TB 64-5M-15	64	8F	GG	101,86	100,72	106,0	20,5	25	25	4,5	—	78	—	1210	0,960	96,64
TB 72-5M-15	72	8F	GG	114,59	113,45	119,0	20,5	25	25	4,5	—	90	—	1610	1,190	105,92
TB 80-5M-15	80	8F	GG	127,32	126,18	135,0	20,5	25	25	4,5	—	92	—	1610	1,570	114,24
TB 90-5M-15	90	7A	GG	143,24	142,10	—	20,5	25	25	2,3	—	92	—	1610	1,147	124,48
TB 112-5M-15	112	7A	GG	178,25	177,11	—	20,5	25	25	2,3	—	92	—	1610	1,940	173,92
TB 136-5M-15	136	7A	GG	216,45	215,31	—	20,5	32	32	5,8	—	106	—	2012	3,060	215,52
TB 150-5M-15	150	7A	GG	238,73	237,59	—	20,5	32	32	5,8	—	106	—	2012	3,900	254,40

Taper-Buchse Taper bushing	1008	1108	1210	1610	2012
Bohrung d ₂ (mm) von ... bis ... Bore d ₂ (mm) from ... to ...	10-25	10-28	11-32	14-42	14-50
Fr./Stück each	12,48	12,96	18,40	20,80	24,64

GG = Grauguss Cast iron
 St = Stahl Steel

Fertigungstechnische Änderungen vorbehalten.
 We reserve the right to make technical changes.

Bohrungsdurchmesser d₂ siehe Seite 3.
 Bore diameters d₂ see page 3.

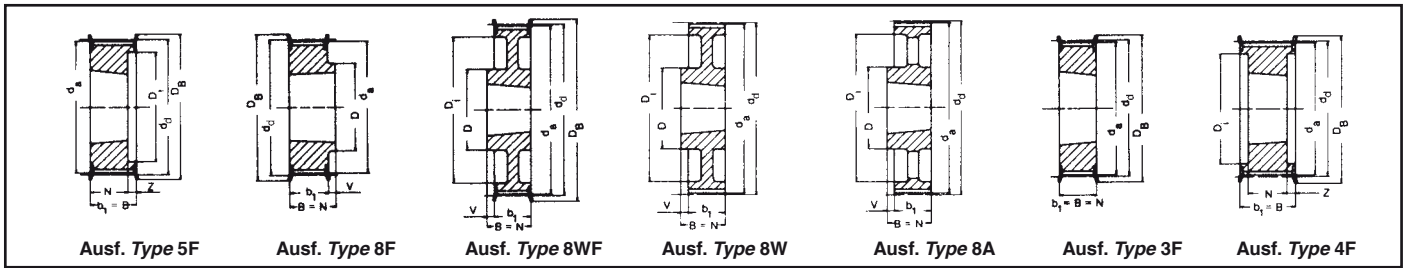

Profil Profile 8M – Teilung Pitch 8 mm für Riemenbreite for belt width 20 mm

Bezeichnung Part No.	Anzahl der Zähne No. of teeth	Aus- füh- rung Type	Material	d _d (mm)	d _a (mm)	D _B (mm)	b ₁ (mm)	B (mm)	N (mm)	V (mm)	Z (mm)	D (mm)	D ₁ (mm)	Taper- Buchse Taper bushing	Gewicht ohne Buchse Weight without bushing (≈ kg)	Fr. Stück ohne Buchse each without bushing
TB 22-8M-20	22	5F	GG	56,02	54,65	60,0	28	28	22	—	6	—	41	1008	0,24	55,68
TB 24-8M-20	24	5F	GG	61,12	59,75	66,0	28	28	22	—	6	—	42	1108	0,30	56,96
TB 26-8M-20	26	5F	GG	66,21	64,84	71,0	28	28	22	—	6	—	46	1108	0,36	59,36
TB 28-8M-20	28	5F	GG	71,30	69,93	75,0	28	28	22	—	6	—	50	1108	0,44	59,84
TB 30-8M-20	30	5F	GG	76,39	75,02	83,0	28	28	22	—	6	—	58	1108	0,53	62,24
TB 32-8M-20	32	5F	GG	81,49	80,12	87,0	28	28	25	—	3	—	62	1610	0,42	63,84
TB 34-8M-20	34	5F	GG	86,58	85,22	91,0	28	28	25	—	3	—	65	1610	0,55	67,84
TB 36-8M-20	36	5F	GG	91,67	90,30	98,5	28	28	25	—	3	—	68	1610	0,68	70,72
TB 38-8M-20	38	5F	GG	96,77	95,39	103,0	28	28	25	—	3	—	72	1610	0,80	74,08
TB 40-8M-20	40	5F	GG	101,86	100,49	106,0	28	28	25	—	3	—	76	1610	1,00	80,48
TB 44-8M-20	44	8F	GG	112,05	110,67	119,0	28	32	32	4	—	93	—	2012	1,20	92,32
TB 48-8M-20	48	8F	GG	122,23	120,86	127,0	28	32	32	4	—	96	—	2012	1,60	104,64
TB 56-8M-20	56	8F	GG	142,60	141,23	148,0	28	32	32	4	—	110	—	2012	2,40	142,72
TB 64-8M-20	64	8WF	GG	162,97	161,60	168,0	28	32	32	4	—	110	137	2012	2,70	179,20
TB 72-8M-20	72	8WF	GG	183,35	181,97	192,0	28	32	32	4	—	110	158	2012	3,30	219,20
TB 80-8M-20	80	8W	GG	203,72	202,35	—	28	32	32	4	—	110	180	2012	3,50	216,16
TB 90-8M-20	90	8A	GG	229,18	227,81	—	28	32	32	4	—	110	204	2012	3,65	248,16

Profil Profile 8M – Teilung Pitch 8 mm für Riemenbreite for belt width 30 mm

TB 22-8M-30	22	5F	GG	56,02	54,65	60,0	38	38	22	—	16	—	41	1008	0,29	62,24
TB 24-8M-30	24	5F	GG	61,12	59,75	66,0	38	38	22	—	16	—	42	1108	0,38	63,20
TB 26-8M-30	26	5F	GG	66,21	64,84	71,0	38	38	22	—	16	—	46	1108	0,45	66,08
TB 28-8M-30	28	5F	St	71,30	69,93	75,0	38	38	25	—	13	—	50	1210	0,50	68,32
TB 30-8M-30	30	3F	St	76,39	75,02	83,0	38	38	38	—	—	—	—	1615	0,45	70,40
TB 32-8M-30	32	3F	GG	81,49	80,12	87,0	38	38	38	—	—	—	—	1615	0,59	71,84
TB 34-8M-30	34	3F	GG	86,58	85,22	91,0	38	38	38	—	—	—	—	1615	0,77	76,16
TB 36-8M-30	36	3F	GG	91,67	90,30	98,5	38	38	38	—	—	—	—	1615	0,96	78,88
TB 38-8M-30	38	3F	GG	96,77	95,39	103,0	38	38	38	—	—	—	—	1615	1,15	85,60
TB 40-8M-30	40	3F	GG	101,86	100,49	106,0	38	38	38	—	—	—	—	1615	1,34	90,40
TB 44-8M-30	44	4F	GG	112,05	110,67	119,0	38	38	32	—	3	—	91	2012	1,33	105,76
TB 48-8M-30	48	4F	GG	122,23	120,86	127,0	38	38	32	—	3	—	95	2012	1,78	119,52
TB 56-8M-30	56	4F	GG	142,60	141,23	148,0	38	38	32	—	3	—	117	2012	3,76	167,84
TB 64-8M-30	64	8F	GG	162,97	161,60	168,0	38	45	45	7	—	125	—	2517	4,20	202,24
TB 72-8M-30	72	8WF	GG	183,35	181,97	192,0	38	45	45	7	—	125	158	2517	4,30	252,00
TB 80-8M-30	80	8W	GG	203,72	202,35	—	38	45	45	7	—	125	180	2517	4,60	265,92
TB 90-8M-30	90	8A	GG	229,18	227,81	—	38	45	45	7	—	125	204	2517	5,00	310,24
TB 112-8M-30	112	8A	GG	285,21	283,83	—	38	45	45	7	—	125	260	2517	6,20	391,84
TB 144-8M-30	144	8A	GG	366,69	365,32	—	38	45	45	7	—	125	341	2517	9,00	525,60

Taper-Buchse Taper bushing	1008	1108	1210	1610	1615	2012	2517
Bohrung d ₂ (mm) von ... bis ... Bore d ₂ (mm) from ... to ...	10-25	10-28	11-32	14-42	14-42	14-50	16-60
Fr./Stück each	12,48	12,96	18,40	20,80	23,04	24,64	37,60

St = Stahl Steel – GG = Grauguss Cast iron
 Fertigungstechnische Änderungen vorbehalten.
 We reserve the right to make technical changes.

Bohrungsdurchmesser d₂ siehe Seite 3.
 Bore diameters d₂ see page 3.

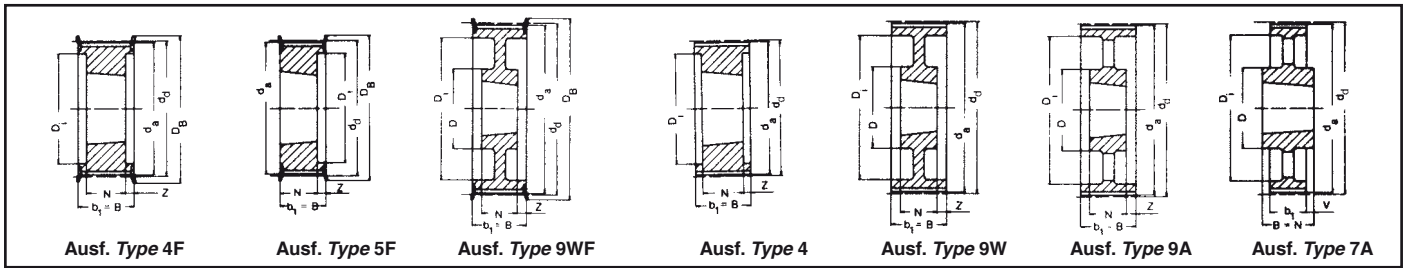

Profil Profile 8M – Teilung Pitch 8 mm für Riemenbreite for belt width 50 mm

Bezeichnung Part No.	Anzahl der Zähne No. of teeth	Aus- füh- rung Type	Matе- rial	d _d (mm)	d _a (mm)	D _B (mm)	b ₁ (mm)	B (mm)	N (mm)	V (mm)	Z (mm)	D (mm)	D _i (mm)	Taper- Buchse Taper bushing	Gewicht ohne Buchse Weight without bushing (≈ kg)	Fr. Stück ohne Buchse each without bushing
TB 28-8M-50	28	5F	St	71,30	69,93	75,0	60	60	25	—	35,0	—	50	1210	0,60	79,84
TB 30-8M-50	30	5F	St	76,39	75,02	83,0	60	60	38	—	22,0	—	58	1615	0,65	85,60
TB 32-8M-50	32	5F	GG	81,49	80,12	87,0	60	60	38	—	22,0	—	62	1615	0,82	91,52
TB 34-8M-50	34	5F	GG	86,58	85,22	91,0	60	60	38	—	22,0	—	65	1615	1,06	97,76
TB 36-8M-50	36	5F	GG	91,67	90,30	98,5	60	60	38	—	22,0	—	68	1615	1,30	104,64
TB 38-8M-50	38	5F	GG	96,77	95,39	103,0	60	60	38	—	22,0	—	72	1615	1,60	112,80
TB 40-8M-50	40	4F	GG	101,86	100,49	106,0	60	60	32	—	14,0	—	82	2012	1,71	118,56
TB 44-8M-50	44	4F	GG	112,05	110,67	119,0	60	60	32	—	14,0	—	91	2012	1,78	139,52
TB 48-8M-50	48	4F	GG	122,23	120,86	127,0	60	60	32	—	14,0	—	95	2012	2,30	154,08
TB 56-8M-50	56	4F	GG	142,60	141,23	148,0	60	60	45	—	7,5	—	116	2517	3,40	212,64
TB 64-8M-50	64	4F	GG	162,97	161,60	168,0	60	60	45	—	7,5	—	137	2517	5,00	260,64
TB 72-8M-50	72	9WF	GG	183,35	181,97	192,0	60	60	45	—	7,5	125	158	2517	6,70	315,68
TB 80-8M-50	80	4	GG	203,72	202,35	—	60	60	51	—	4,5	—	180	3020	8,80	344,32
TB 90-8M-50	90	9W	GG	229,18	227,81	—	60	60	51	—	4,5	170	204	3020	10,00	413,76
TB 112-8M-50	112	9W	GG	285,21	283,83	—	60	60	51	—	4,5	170	260	3020	12,00	541,44
TB 144-8M-50	144	9A	GG	366,69	365,32	—	60	60	51	—	4,5	170	341	3020	15,20	692,96
TB 168-8M-50	168	7A	GG	427,81	426,44	—	60	65	65	—	2,5	170	402	3525	16,40	973,60
TB 192-8M-50	192	7A	GG	488,92	487,55	—	60	65	65	—	2,5	170	460	3525	21,80	1.179,68

Profil Profile 8M – Teilung Pitch 8 mm für Riemenbreite for belt width 85 mm

TB 34-8M-85	34	4F	GG	86,58	85,22	91,0	95	95	38	—	28,5	—	65	1615	1,43	139,36
TB 36-8M-85	36	4F	GG	91,67	90,30	98,5	95	95	38	—	28,5	—	68	1615	1,87	152,00
TB 38-8M-85	38	4F	GG	96,77	95,39	103,0	95	95	38	—	28,5	—	72	1615	2,20	160,80
TB 40-8M-85	40	4F	GG	101,86	100,49	106,0	95	95	32	—	31,5	—	82	2012	1,78	171,84
TB 44-8M-85	44	4F	GG	112,05	110,67	119,0	95	95	32	—	31,5	—	91	2012	2,30	181,76
TB 48-8M-85	48	4F	GG	122,23	120,86	127,0	95	95	45	—	25,0	—	100	2517	2,66	204,96
TB 56-8M-85	56	4F	GG	142,60	141,23	148,0	95	95	45	—	25,0	—	117	2517	4,45	287,20
TB 64-8M-85	64	4F	GG	162,97	161,60	168,0	95	95	45	—	25,0	—	137	2517	6,20	355,52
TB 72-8M-85	72	4F	GG	183,35	181,97	192,0	95	95	51	—	22,0	—	158	3020	8,00	444,32
TB 80-8M-85	80	4	GG	203,72	202,35	—	95	95	51	—	22,0	—	180	3020	10,00	450,24
TB 90-8M-85	90	9W	GG	229,18	227,81	—	95	95	51	—	22,0	170	204	3020	10,80	524,64
TB 112-8M-85	112	9W	GG	285,21	283,83	—	95	95	51	—	22,0	170	260	3020	15,00	696,48
TB 144-8M-85	144	9A	GG	366,69	365,32	—	95	95	76	—	15,0	170	341	3525	20,00	1.026,56
TB 168-8M-85	168	9A	GG	427,81	426,44	—	95	95	76	—	15,0	170	402	3525	23,00	1.232,80
TB 192-8M-85	192	9A	GG	488,92	487,55	—	95	95	76	—	15,0	170	460	3525	28,50	1.480,32

Taper-Buchse Taper bushing	1210	1615	2012	2517	3020	3525
Bohrung d ₂ (mm) von ... bis ... Bore d ₂ (mm) from ... to ...	11-32	14-42	14-50	16-60	25-75	35-90
Fr./Stück each	18,40	23,04	24,64	37,60	50,24	102,56

St = Stahl *Steel* – GG = Grauguss *Cast iron*
 Fertigungstechnische Änderungen vorbehalten.
 We reserve the right to make technical changes.

Bohrungsdurchmesser d₂ siehe Seite 3.
 Bore diameters d₂ see page 3.

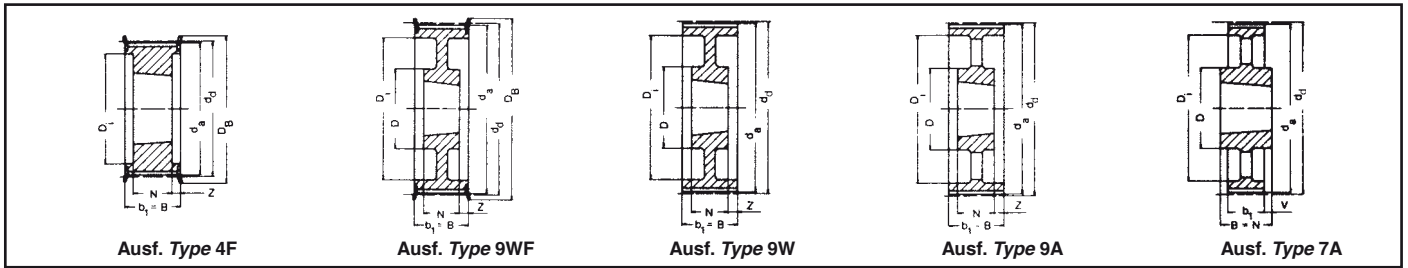

Profil Profile 14M – Teilung Pitch 14 mm für Riemenbreite for belt width 40 mm

Bezeichnung Part No.	Anzahl der Zähne No. of teeth	Aus- füh- rung Type	Material	d _d (mm)	d _a (mm)	D _B (mm)	b ₁ (mm)	B (mm)	N (mm)	V (mm)	Z (mm)	D (mm)	D ₁ (mm)	Taper- Buchse Taper bushing	Gewicht ohne Buchse Weight without bushing (≈ kg)	Fr. Stück ohne Buchse each without bushing
TB 28-14M-40	28	4F	GG	124,78	122,12	127	54	54	32	—	11,0	—	98	2012	2,00	182,24
TB 29-14M-40	29	4F	GG	129,23	126,57	138	54	54	32	—	11,0	—	100	2012	2,38	188,32
TB 30-14M-40	30	4F	GG	133,69	130,99	138	54	54	32	—	11,0	—	100	2012	2,65	200,48
TB 32-14M-40	32	4F	GG	142,60	139,88	154	54	54	32	—	11,0	—	104	2012	3,40	219,84
TB 34-14M-40	34	4F	GG	151,52	148,79	160	54	54	45	—	4,5	—	110	2517	3,87	253,12
TB 36-14M-40	36	4F	GG	160,43	157,68	168	54	54	45	—	4,5	—	120	2517	4,80	285,12
TB 38-14M-40	38	4F	GG	169,34	166,60	183	54	54	45	—	4,5	—	130	2517	5,40	299,04
TB 40-14M-40	40	4F	GG	178,25	175,49	188	54	54	45	—	4,5	—	138	2517	6,00	327,84
TB 44-14M-40	44	4F	GG	196,08	193,28	211	54	54	51	—	1,5	—	155	3020	7,80	356,32
TB 48-14M-40	48	4F	GG	213,90	211,11	226	54	54	51	—	1,5	—	170	3020	9,40	441,28
TB 56-14M-40	56	9WF	GG	249,55	246,76	256	54	54	51	—	1,5	170	208	3020	10,80	506,88
TB 64-14M-40	64	9WF	GG	285,21	282,41	296	54	54	51	—	1,5	170	242	3020	13,40	553,92
TB 72-14M-40	72	9W	GG	320,86	318,06	—	54	54	51	—	1,5	170	280	3020	15,20	638,08
TB 80-14M-40	80	9A	GG	356,51	353,71	—	54	54	51	—	1,5	170	315	3020	16,00	712,80
TB 90-14M-40	90	9A	GG	401,07	398,28	—	54	54	51	—	1,5	170	360	3020	17,80	805,76
TB 112-14M-40	112	9A	GG	499,11	496,32	—	54	54	51	—	1,5	170	457	3020	25,60	1.049,12
TB 144-14M-40	144	9A	GG	641,71	638,92	—	54	54	51	—	1,5	170	600	3020	32,00	1.595,04
TB 168-14M-40	168	9A	GG	748,66	745,87	—	54	54	51	—	1,5	170	706	3020	44,00	1.731,68
TB 192-14M-40	192	9A	GG	855,62	852,82	—	54	54	51	—	1,5	170	813	3020	49,00	2.121,28
TB 216-14M-40	216	9A	GG	962,57	959,77	—	54	54	51	—	1,5	170	920	3020	55,00	2.777,92

Profil Profile 14M – Teilung Pitch 14 mm für Riemenbreite for belt width 55 mm

TB 28-14M-55	28	4F	GG	124,78	122,12	127	70	70	32	—	19,0	—	98	2012	2,20	208,16
TB 29-14M-55	29	4F	GG	129,23	126,57	138	70	70	32	—	19,0	—	100	2012	2,74	226,88
TB 30-14M-55	30	4F	GG	133,69	130,99	138	70	70	45	—	12,5	—	100	2517	2,70	238,24
TB 32-14M-55	32	4F	GG	142,60	139,88	154	70	70	45	—	12,5	—	108	2517	3,66	270,56
TB 34-14M-55	34	4F	GG	151,52	148,79	160	70	70	45	—	12,5	—	110	2517	4,55	304,32
TB 36-14M-55	36	4F	GG	160,43	157,68	168	70	70	45	—	12,5	—	120	2517	5,20	345,60
TB 38-14M-55	38	4F	GG	169,34	166,60	183	70	70	45	—	12,5	—	130	2517	6,20	359,84
TB 40-14M-55	40	4F	GG	178,25	175,49	188	70	70	45	—	12,5	—	138	2517	7,00	386,40
TB 44-14M-55	44	4F	GG	196,08	193,28	211	70	70	51	—	9,5	—	155	3020	8,60	437,76
TB 48-14M-55	48	4F	GG	213,90	211,11	226	70	70	51	—	9,5	—	170	3020	10,40	499,84
TB 56-14M-55	56	9WF	GG	249,55	246,76	256	70	70	51	—	9,5	170	208	3020	12,00	635,20
TB 64-14M-55	64	9WF	GG	285,21	282,41	296	70	70	51	—	9,5	170	242	3020	14,50	669,12
TB 72-14M-55	72	9W	GG	320,86	318,06	—	70	70	51	—	9,5	170	280	3020	16,20	723,68
TB 80-14M-55	80	9A	GG	356,51	353,71	—	70	70	51	—	9,5	170	315	3020	17,50	798,40
TB 90-14M-55	90	9A	GG	401,07	398,28	—	70	70	51	—	9,5	170	360	3020	20,10	889,60
TB 112-14M-55	112	9A	GG	499,11	496,32	—	70	70	51	—	9,5	170	457	3020	28,40	1.158,72
TB 144-14M-55	144	9A	GG	641,71	638,92	—	70	70	51	—	9,5	170	600	3020	36,20	1.711,04
TB 168-14M-55	168	9A	GG	748,66	745,87	—	70	70	51	—	9,5	170	706	3020	49,00	2.212,00
TB 192-14M-55	192	9A	GG	855,62	852,82	—	70	70	51	—	9,5	170	813	3020	53,00	2.544,64
TB 216-14M-55	216	7A	GG	962,57	959,77	—	70	89	89	9,5	—	190	920	3535	65,80	3.300,00

Taper-Buchse Taper bushing	2012	2517	3020	3535
Bohrung d ₂ (mm) von ... bis ... Bore d ₂ (mm) from ... to ...	14-50	16-60	25-75	35-90
Fr./Stück each	24,64	37,60	50,24	127,04

GG = Grauguss Cast iron
 Fertigungstechnische Änderungen vorbehalten.
 We reserve the right to make technical changes.
 Bohrungsdurchmesser d₂ siehe Seite 3.
 Bore diameters d₂ see page 3.

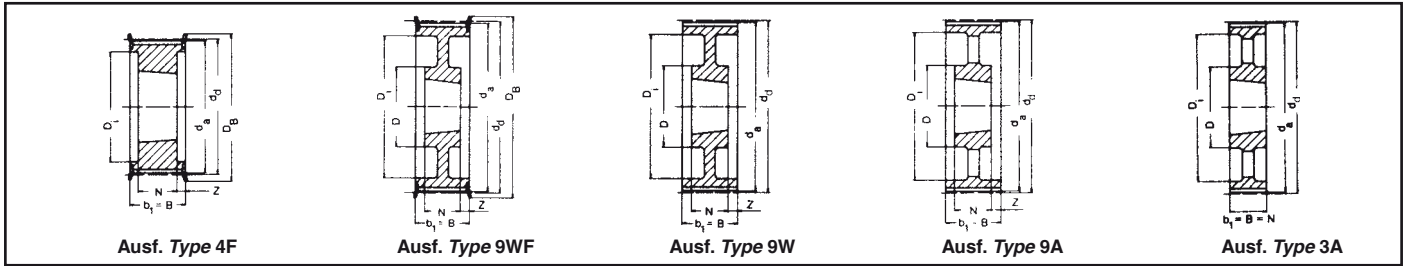

Profil Profile 14M – Teilung Pitch 14 mm für Riemenbreite for belt width 85 mm

Bezeichnung Part No.	Anzahl der Zähne No. of teeth	Aus- füh- rung Type	Mate- rial	d _d (mm)	d _a (mm)	D _B (mm)	b ₁ (mm)	B (mm)	N (mm)	V (mm)	Z (mm)	D (mm)	D _i (mm)	Taper- Buchse Taper bushing	Gewicht ohne Buchse Weight without bushing (≈ kg)	Fr. Stück ohne Buchse each without bushing
TB 28-14M-85	28	4F	GG	124,78	122,12	127	102	102	45	—	28,5	—	98	2517	2,70	261,28
TB 29-14M-85	29	4F	GG	129,23	126,57	138	102	102	45	—	28,5	—	100	2517	3,40	294,24
TB 30-14M-85	30	4F	GG	133,69	130,99	138	102	102	45	—	28,5	—	100	2517	3,75	315,84
TB 32-14M-85	32	4F	GG	142,60	139,88	154	102	102	45	—	28,5	—	108	2517	4,80	357,44
TB 34-14M-85	34	4F	GG	151,52	148,79	160	102	102	45	—	28,5	—	110	2517	6,00	408,64
TB 36-14M-85	36	4F	GG	160,43	157,68	168	102	102	51	—	25,5	—	120	3020	5,80	458,56
TB 38-14M-85	38	4F	GG	169,34	166,60	183	102	102	51	—	25,5	—	130	3020	6,80	471,68
TB 40-14M-85	40	4F	GG	178,25	175,49	188	102	102	51	—	25,5	—	138	3020	8,00	506,88
TB 44-14M-85	44	4F	GG	196,08	193,28	211	102	102	76	—	13,0	—	155	3030	11,80	601,60
TB 48-14M-85	48	4F	GG	213,90	211,11	226	102	102	76	—	13,0	—	170	3030	15,10	649,92
TB 56-14M-85	56	4F	GG	249,55	246,76	256	102	102	65	—	18,5	190	210	3525	19,00	812,96
TB 64-14M-85	64	9WF	GG	285,21	282,41	296	102	102	65	—	18,5	190	242	3525	23,00	853,12
TB 72-14M-85	72	9W	GG	320,86	318,06	—	102	102	65	—	18,5	190	280	3525	25,00	941,44
TB 80-14M-85	80	9A	GG	356,51	353,71	—	102	102	65	—	18,5	190	315	3525	26,00	984,16
TB 90-14M-85	90	9A	GG	401,07	398,28	—	102	102	65	—	18,5	190	360	3525	27,80	1.179,04
TB 112-14M-85	112	9A	GG	499,11	496,32	—	102	102	65	—	18,5	190	457	3525	36,50	1.595,04
TB 144-14M-85	144	9A	GG	641,71	638,92	—	102	102	65	—	18,5	190	600	3525	48,00	2.064,48
TB 168-14M-85	168	9A	GG	748,66	745,87	—	102	102	65	—	18,5	190	706	3525	60,00	2.582,56
TB 192-14M-85	192	3A	GG	855,62	852,82	—	102	102	102	—	—	230	813	4040	86,00	3.216,64
TB 216-14M-85	216	3A	GG	962,57	959,77	—	102	102	102	—	—	230	920	4040	91,50	4.101,76

Profil Profile 14M – Teilung Pitch 14 mm für Riemenbreite for belt width 115 mm

TB 28-14M-115	28	4F	GG	124,78	122,12	127	133	133	45	—	44,0	—	98	2517	3,77	366,08
TB 29-14M-115	29	4F	GG	129,23	126,57	138	133	133	45	—	44,0	—	100	2517	4,00	415,68
TB 30-14M-115	30	4F	GG	133,69	130,99	138	133	133	45	—	44,0	—	100	2517	5,00	428,80
TB 32-14M-115	32	4F	GG	142,60	139,88	154	133	133	45	—	44,0	—	108	2517	6,80	471,36
TB 34-14M-115	34	4F	GG	151,52	148,79	160	133	133	45	—	44,0	—	110	2517	6,80	514,56
TB 36-14M-115	36	4F	GG	160,43	157,68	168	133	133	51	—	41,0	—	120	3020	7,00	594,24
TB 38-14M-115	38	4F	GG	169,34	166,60	183	133	133	51	—	41,0	—	130	3020	8,40	609,12
TB 40-14M-115	40	4F	GG	178,25	175,49	188	133	133	51	—	41,0	—	140	3020	9,20	664,80
TB 44-14M-115	44	4F	GG	196,08	193,28	211	133	133	76	—	28,5	—	155	3030	14,00	769,44
TB 48-14M-115	48	4F	GG	213,90	211,11	226	133	133	76	—	28,5	—	170	3030	17,10	957,12
TB 56-14M-115	56	4F	GG	249,55	246,76	256	133	133	89	—	22,0	—	210	3535	24,80	1.015,20
TB 64-14M-115	64	9WF	GG	285,21	282,41	296	133	133	89	—	22,0	190	242	3535	27,00	1.064,64
TB 72-14M-115	72	9W	GG	320,86	318,06	—	133	133	89	—	22,0	190	280	3535	29,00	1.169,76
TB 80-14M-115	80	9A	GG	356,51	353,71	—	133	133	89	—	22,0	190	315	3535	32,00	1.408,32
TB 90-14M-115	90	9A	GG	401,07	398,28	—	133	133	89	—	22,0	190	360	3535	36,50	1.606,72
TB 112-14M-115	112	9A	GG	499,11	496,32	—	133	133	89	—	22,0	190	457	3535	46,00	2.049,92
TB 144-14M-115	144	9A	GG	641,71	638,92	—	133	133	102	—	15,5	230	600	4040	68,00	2.614,72
TB 168-14M-115	168	9A	GG	748,66	745,87	—	133	133	102	—	15,5	230	706	4040	82,60	3.280,16
TB 192-14M-115	192	9A	GG	855,62	852,82	—	133	133	102	—	15,5	230	813	4040	96,00	3.934,88
TB 216-14M-115	216	9A	GG	962,57	959,77	—	133	133	102	—	15,5	230	920	4040	107,00	4.990,88

Taper-Buchse Taper bushing	2517	3020	3030	3525	3535	4040
Bohrung d ₂ (mm) von ... bis ... Bore d ₂ (mm) from ... to ...	16-60	25-75	35-75	35-90	35-90	40-100
Fr./Stück each	37,60	50,24	66,08	102,56	127,04	178,56

GG = Grauguss Cast iron
 Fertigungstechnische Änderungen vorbehalten.
 We reserve the right to make technical changes.
 Bohrungsdurchmesser d₂ siehe Seite 3.
 Bore diameters d₂ see page 3.

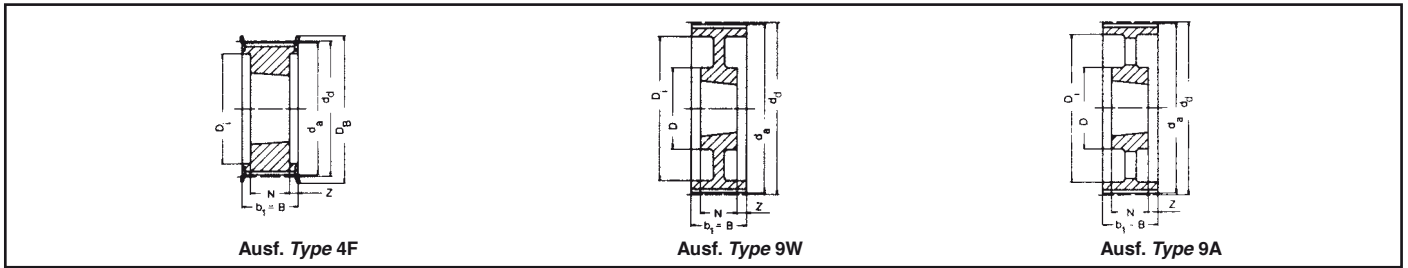

Profil Profile 14M – Teilung Pitch 14 mm für Riemenbreite for belt width 170 mm

Bezeichnung Part No.	Anzahl der Zähne No. of teeth	Aus- füh- rung Type	Material	d _d (mm)	d _a (mm)	D _B (mm)	b ₁ (mm)	B (mm)	N (mm)	V (mm)	Z (mm)	D (mm)	D ₁ (mm)	Taper- Buchse Taper bushing	Gewicht ohne Buchse Weight without bushing (≈ kg)	Fr. Stück ohne Buchse each without bushing
TB 38-14M-170*	38	4F	GG	169,34	166,60	183	187	187	76	—	55,5	—	130	3030	11,70	952,80
TB 40-14M-170*	40	4F	GG	178,25	175,49	188	187	187	76	—	55,5	—	140	3030	13,00	983,04
TB 44-14M-170*	44	4F	GG	196,08	193,28	211	187	187	89	—	49,0	—	155	3535	15,00	1.062,56
TB 48-14M-170*	48	4F	GG	213,90	211,11	226	187	187	89	—	49,0	—	175	3535	19,00	1.317,76
TB 56-14M-170*	56	4F	GG	249,55	246,76	256	187	187	89	—	49,0	—	210	3535	28,50	1.411,20
TB 64-14M-170*	64	4F	GG	285,21	282,41	296	187	187	102	—	42,5	—	240	4040	41,00	1.520,00
TB 72-14M-170*	72	9W	GG	320,86	318,06	—	187	187	102	—	42,5	230	280	4040	46,90	1.657,76
TB 80-14M-170*	80	9W	GG	356,51	353,71	—	187	187	102	—	42,5	230	315	4040	48,00	2.113,92
TB 90-14M-170*	90	9A	GG	401,07	398,28	—	187	187	102	—	42,5	230	360	4040	52,50	2.356,64
TB 112-14M-170*	112	9A	GG	499,11	496,32	—	187	187	127	—	30,0	265	457	5050	74,50	2.871,04
TB 144-14M-170*	144	9A	GG	641,71	638,92	—	187	187	127	—	30,0	265	600	5050	91,00	3.597,12
TB 168-14M-170*	168	9A	GG	748,66	745,87	—	187	187	127	—	30,0	265	706	5050	116,00	4.501,60
TB 192-14M-170*	192	9A	GG	855,62	852,82	—	187	187	127	—	30,0	265	813	5050	134,00	5.264,48
TB 216-14M-170*	216	9A	GG	962,57	959,77	—	187	187	127	—	30,0	265	920	5050	146,50	6.642,72

HTD®-Zahnscheiben Type 20M auf Anfrage
HTD® pulleys profile 20M on request

Taper-Buchse Taper bushing	3030	3535	4040	5050
Bohrung d ₂ (mm) von ... bis ... Bore d ₂ (mm) from ... to ...	35-75	35-90	40-100	70-125
Fr./Stück each	66,08	127,04	178,56	347,20

GG = Grauguss Cast iron
 Fertigungstechnische Änderungen vorbehalten.
 We reserve the right to make technical changes.
 * Keine Lagerware Non stock items
 Bohrungsdurchmesser d₂ siehe Seite 3.
 Bore diameters d₂ see page 3.

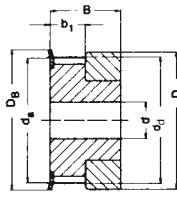

Ausf. Type 1F

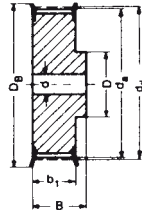

Ausf. Type 6F

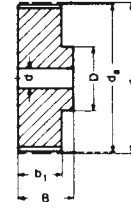

Ausf. Type 6

Profil Profile T2,5 – Teilung Pitch 2,5 mm für Riemenbreite for belt width 4 und and 6 mm

Bezeichnung Part No.	Anzahl der Zähne No. of teeth	Aus- führung Type	Material	d _d (mm)	d _a (mm)	D _B (mm)	b ₁ (mm)	B (mm)	D (mm)	D _i (mm)	Vor- bohrung Pilot bore d (mm)	Fertig- bohrung Finished bore d _{max} (mm)	Gewicht Weight (≈ kg)	Fr. Stück each
16 T2,5/12-2	12	1F	Al	9,55	9,00	13,0	9	16	12	—	—	3	0,003	17,12
16 T2,5/14-2	14	1F	Al	11,14	10,60	15,0	9	16	14	—	—	4	0,004	17,12
16 T2,5/15-2	15	1F	Al	11,94	11,40	15,0	9	16	15	—	—	4	0,005	17,12
16 T2,5/16-2	16	1F	Al	12,73	12,20	16,0	9	16	16	—	—	5	0,005	17,60
16 T2,5/18-2	18	6F	Al	14,32	13,80	17,5	10	16	9,5	—	4	6	0,006	17,60
16 T2,5/19-2	19	6F	Al	15,12	14,60	18,0	10	16	9,5	—	4	6	0,007	18,08
16 T2,5/20-2	20	6F	Al	15,92	15,40	19,5	10	16	10	—	4	6	0,008	18,08
16 T2,5/22-2	22	6F	Al	17,51	17,00	23,0	10	16	10	—	4	6	0,009	18,08
16 T2,5/24-2	24	6F	Al	19,10	18,55	23,0	10	16	12	—	4	6	0,012	18,88
16 T2,5/25-2	25	6F	Al	19,90	19,35	23,0	10	16	12	—	4	8	0,013	18,88
16 T2,5/26-2	26	6F	Al	20,70	20,15	25,0	10	16	13	—	4	8	0,014	19,36
16 T2,5/28-2	28	6F	Al	22,28	21,75	25,0	10	16	13	—	4	8	0,016	19,36
16 T2,5/30-2	30	6F	Al	23,87	23,35	28,0	10	16	16	—	6	10	0,018	20,16
16 T2,5/32-2	32	6F	Al	25,47	24,95	32,0	10	16	16	—	6	10	0,020	20,00
16 T2,5/36-2	36	6F	Al	28,65	28,10	36,0	10	16	20	—	6	12	0,026	20,64
16 T2,5/40-2	40	6F	Al	31,83	31,30	38,0	10	16	20	—	6	12	0,032	21,12
16 T2,5/44-2	44	6F	Al	35,02	34,50	42,0	10	16	24	—	6	14	0,040	21,92
16 T2,5/48-0	48	6	Al	38,20	37,70	—	10	16	26	—	6	15	0,048	22,40
16 T2,5/60-0	60	6	Al	47,75	47,25	—	10	16	34	—	8	18	0,073	24,16

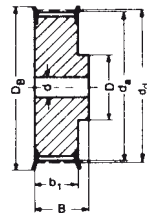

Ausf. Type 6F

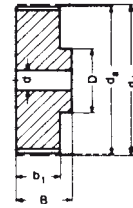

Ausf. Type 6

Profil Profile T5 – Teilung Pitch 5 mm für Riemenbreite for belt width 10 mm

Bezeichnung Part No.	Anzahl der Zähne No. of teeth	Aus- führung Type	Material	d _d (mm)	d _a (mm)	D _B (mm)	b ₁ (mm)	B (mm)	D (mm)	D _i (mm)	Vor- bohrung Pilot bore d (mm)	Fertig- bohrung Finished bore d _{max} (mm)	Gewicht Weight (≈ kg)	Fr. Stück each
21 T5/10-2	10	6F	Al	15,92	15,05	19,5	15	21	8	—	—	5	0,012	17,92
21 T5/12-2	12	6F	Al	19,01	18,25	23,0	15	21	10	—	—	6	0,016	18,56
21 T5/14-2	14	6F	Al	22,29	21,45	25,0	15	21	13	—	—	8	0,019	19,20
21 T5/15-2	15	6F	Al	23,88	23,05	28,0	15	21	16	—	6	10	0,021	19,68
21 T5/16-2	16	6F	Al	25,47	24,60	32,0	15	21	18	—	6	11	0,025	20,80
21 T5/18-2	18	6F	Al	28,65	27,80	32,0	15	21	19	—	6	12	0,031	23,68
21 T5/19-2	19	6F	Al	30,25	29,40	36,0	15	21	22	—	6	12	0,036	24,16
21 T5/20-2	20	6F	Al	31,83	31,00	36,0	15	21	23	—	6	14	0,038	24,64
21 T5/22-2	22	6F	Al	35,12	34,25	38,0	15	21	24	—	6	15	0,046	25,44
21 T5/24-2	24	6F	Al	38,21	37,40	42,0	15	21	26	—	6	15	0,054	25,92
21 T5/25-2	25	6F	Al	39,80	39,00	44,0	15	21	26	—	6	15	0,058	26,40
21 T5/26-2	26	6F	Al	41,47	40,60	44,0	15	21	26	—	6	16	0,062	27,68
21 T5/27-2	27	6F	Al	42,98	42,20	48,0	15	21	30	—	8	18	0,064	28,32
21 T5/28-2	28	6F	Al	44,62	43,75	48,0	15	21	32	—	8	18	0,071	28,80
21 T5/30-2	30	6F	Al	47,76	46,95	51,0	15	21	34	—	8	18	0,075	30,24
21 T5/32-2	32	6F	Al	50,94	50,10	54,0	15	21	38	—	8	22	0,088	33,92
21 T5/36-2	36	6F	Al	57,31	56,45	63,0	15	21	38	—	8	22	0,114	36,80
21 T5/40-2	40	6F	Al	63,66	62,85	66,0	15	21	40	—	8	23	0,138	40,80
21 T5/42-2	42	6F	Al	66,87	66,00	71,0	15	21	40	—	8	24	0,180	42,24
21 T5/44-0	44	6	Al	70,07	69,20	—	15	21	45	—	8	26	0,185	42,72
21 T5/48-0	48	6	Al	76,42	75,55	—	15	21	50	—	8	28	0,200	48,32
21 T5/60-0	60	6	Al	95,52	94,65	—	15	21	65	—	8	35	0,307	57,60

Profil Profile T5 – Teilung Pitch 5 mm für Riemenbreite for belt width 16 mm

27 T5/10-2	10	6F	Al	15,92	15,05	19,5	21	27	8	—	—	5	0,016	19,20
27 T5/12-2	12	6F	Al	19,01	18,25	23,0	21	27	10	—	—	6	0,022	19,68
27 T5/14-2	14	6F	Al	22,29	21,45	25,0	21	27	13	—	—	8	0,026	20,32
27 T5/15-2	15	6F	Al	23,88	23,05	28,0	21	27	16	—	6	10	0,029	20,80
27 T5/16-2	16	6F	Al	25,47	24,60	32,0	21	27	18	—	6	11	0,035	22,40
27 T5/18-2	18	6F	Al	28,65	27,80	32,0	21	27	19	—	6	12	0,043	24,64
27 T5/19-2	19	6F	Al	30,25	29,40	36,0	21	27	22	—	6	12	0,049	25,44
27 T5/20-2	20	6F	Al	31,83	31,00	36,0	21	27	23	—	6	14	0,053	26,40
27 T5/22-2	22	6F	Al	35,12	34,25	38,0	21	27	24	—	6	15	0,054	27,04
27 T5/24-2	24	6F	Al	38,21	37,40	42,0	21	27	26	—	6	15	0,076	27,52
27 T5/25-2	25	6F	Al	39,80	39,00	44,0	21	27	26	—	6	15	0,081	28,16
27 T5/26-2	26	6F	Al	41,47	40,60	44,0	21	27	26	—	6	16	0,085	30,56
27 T5/27-2	27	6F	Al	42,98	42,20	48,0	21	27	30	—	8	18	0,090	31,84
27 T5/28-2	28	6F	Al	44,62	43,75	48,0	21	27	32	—	8	18	0,092	33,12
27 T5/30-2	30	6F	Al	47,76	46,95	51,0	21	27	34	—	8	18	0,105	35,36
27 T5/32-2	32	6F	Al	50,94	50,10	54,0	21	27	38	—	8	22	0,123	38,24
27 T5/36-2	36	6F	Al	57,31	56,45	63,0	21	27	38	—	8	22	0,160	41,60
27 T5/40-2	40	6F	Al	63,66	62,85	66,0	21	27	40	—	8	23	0,193	47,04
27 T5/42-2	42	6F	Al	66,87	66,00	71,0	21	27	40	—	8	24	0,205	49,12
27 T5/44-0	44	6	Al	70,07	69,20	—	21	27	45	—	8	26	0,228	51,20
27 T5/48-0	48	6	Al	76,42	75,55	—	21	27	50	—	8	28	0,280	52,16
27 T5/60-0	60	6	Al	95,52	94,65	—	21	27	65	—	8	35	0,430	62,88

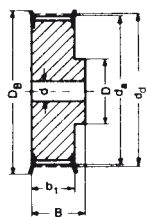

Ausf. Type 6F

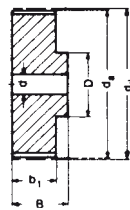

Ausf. Type 6

Profil Profile T5 – Teilung Pitch 5 mm für Riemenbreite for belt width 25 mm

Bezeichnung Part No.	Anzahl der Zähne No. of teeth	Aus- führung Type	Material	d _d (mm)	d _a (mm)	D _B (mm)	b ₁ (mm)	B (mm)	D (mm)	D _i (mm)	Vor- bohrung Pilot bore d (mm)	Fertig- bohrung Finished bore d _{max} (mm)	Gewicht Weight (≈ kg)	Fr. Stück each
36 T5/10-2	10	6F	Al	15,92	15,05	19,5	30	36	8	—	—	5	0,023	25,92
36 T5/12-2	12	6F	Al	19,01	18,25	23,0	30	36	10	—	—	6	0,031	26,40
36 T5/14-2	14	6F	Al	22,29	21,45	25,0	30	36	13	—	—	8	0,037	26,40
36 T5/15-2	15	6F	Al	23,88	23,05	28,0	30	36	16	—	6	10	0,041	27,04
36 T5/16-2	16	6F	Al	25,47	24,60	32,0	30	36	18	—	6	11	0,050	27,52
36 T5/18-2	18	6F	Al	28,65	27,80	32,0	30	36	19	—	6	12	0,061	28,16
36 T5/19-2	19	6F	Al	30,25	29,40	36,0	30	36	22	—	6	12	0,070	28,64
36 T5/20-2	20	6F	Al	31,83	31,00	36,0	30	36	23	—	6	14	0,076	29,44
36 T5/22-2	22	6F	Al	35,12	34,25	38,0	30	36	24	—	6	15	0,080	31,04
36 T5/24-2	24	6F	Al	38,21	37,40	42,0	30	36	26	—	8	15	0,109	32,96
36 T5/25-2	25	6F	Al	39,80	39,00	44,0	30	36	26	—	8	15	0,116	34,24
36 T5/26-2	26	6F	Al	41,47	40,60	44,0	30	36	26	—	8	16	0,120	37,60
36 T5/27-2	27	6F	Al	42,98	42,20	48,0	30	36	30	—	8	18	0,128	38,56
36 T5/28-2	28	6F	Al	44,62	43,75	48,0	30	36	32	—	8	18	0,135	40,16
36 T5/30-2	30	6F	Al	47,76	46,95	51,0	30	36	34	—	8	18	0,150	41,60
36 T5/32-2	32	6F	Al	50,94	50,10	54,0	30	36	38	—	8	22	0,176	45,92
36 T5/36-2	36	6F	Al	57,31	56,45	63,0	30	36	38	—	8	22	0,230	49,28
36 T5/40-2	40	6F	Al	63,66	62,85	66,0	30	36	40	—	8	23	0,276	53,28
36 T5/42-2	42	6F	Al	66,87	66,00	71,0	30	36	40	—	8	24	0,284	54,40
36 T5/44-0	44	6	Al	70,07	69,20	—	30	36	45	—	8	26	0,315	57,92
36 T5/48-0	48	6	Al	76,42	75,55	—	30	36	50	—	8	28	0,400	61,12
36 T5/60-0	60	6	Al	95,52	94,65	—	30	36	65	—	8	35	0,614	75,84

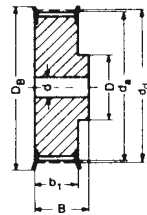

Ausf. Type 6F

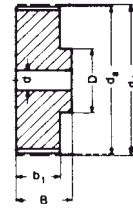

Ausf. Type 6

Profil Profile T10 – Teilung Pitch 10 mm für Riemenbreite for belt width 16 mm

Bezeichnung Part No.	Anzahl der Zähne No. of teeth	Aus- führung Type	Material	d_d (mm)	d_a (mm)	D_B (mm)	b_1 (mm)	B (mm)	D (mm)	D_i (mm)	Vor- bohrung Pilot bore d (mm)	Fertig- bohrung Finished bore d_{max} (mm)	Gewicht Weight (≈ kg)	Fr. Stück each
31 T10/12-2	12	6F	Al	38,20	36,35	42	21	31	28	—	6	16	0,076	28,48
31 T10/14-2	14	6F	Al	44,56	42,70	48	21	31	32	—	8	18	0,104	30,40
31 T10/15-2	15	6F	Al	47,75	45,90	51	21	31	32	—	8	18	0,116	33,44
31 T10/16-2	16	6F	Al	50,93	49,05	54	21	31	35	—	8	20	0,134	36,48
31 T10/18-2	18	6F	Al	57,29	55,45	60	21	31	40	—	8	22	0,167	40,48
31 T10/19-2	19	6F	Al	60,48	58,60	66	21	31	44	—	8	22	0,184	44,00
31 T10/20-2	20	6F	Al	63,66	61,80	66	21	31	46	—	8	24	0,208	46,88
31 T10/22-2	22	6F	Al	70,03	68,15	75	21	31	52	—	8	28	0,253	49,92
31 T10/24-2	24	6F	Al	76,39	74,55	83	21	31	58	—	8	30	0,288	56,32
31 T10/25-2	25	6F	Al	79,58	77,70	83	21	31	60	—	8	30	0,310	58,24
31 T10/26-2	26	6F	Al	82,76	80,90	87	21	31	60	—	8	30	0,357	61,12
31 T10/27-2	27	6F	Al	85,95	84,10	91	21	31	60	—	8	30	0,364	64,64
31 T10/28-2	28	6F	Al	89,13	87,25	93	21	31	60	—	8	30	0,401	67,52
31 T10/30-2	30	6F	Al	95,49	93,65	97	21	31	60	—	8	30	0,441	73,12
31 T10/32-2	32	6F	Al	101,86	100,00	106	21	31	65	—	10	32	0,493	85,92
31 T10/36-2	36	6F	Al	114,59	112,75	119	21	31	70	—	10	35	0,623	97,60
31 T10/40-2	40	6F	Al	127,32	125,45	131	21	31	80	—	10	40	0,767	123,04
31 T10/44-0	44	6	Al	140,06	138,20	—	21	31	88	—	10	46	0,993	134,72
31 T10/48-0	48	6	Al	152,78	150,95	—	21	31	95	—	16	48	1,090	149,60
31 T10/60-0	60	6	Al	190,98	189,10	—	21	31	110	—	16	60	1,710	211,68

Profil Profile T10 – Teilung Pitch 10 mm für Riemenbreite for belt width 25 mm

40 T10/12-2	12	6F	Al	38,20	36,35	42	30	40	28	—	6	16	0,099	31,68
40 T10/14-2	14	6F	Al	44,56	42,70	48	30	40	32	—	8	18	0,134	35,84
40 T10/15-2	15	6F	Al	47,75	45,90	51	30	40	32	—	8	18	0,152	39,68
40 T10/16-2	16	6F	Al	50,93	49,05	54	30	40	35	—	8	20	0,176	42,88
40 T10/18-2	18	6F	Al	57,29	55,45	60	30	40	40	—	8	22	0,224	48,32
40 T10/19-2	19	6F	Al	60,48	58,60	66	30	40	44	—	8	22	0,247	52,32
40 T10/20-2	20	6F	Al	63,66	61,80	66	30	40	46	—	8	24	0,276	55,20
40 T10/22-2	22	6F	Al	70,03	68,15	75	30	40	52	—	8	28	0,337	59,20
40 T10/24-2	24	6F	Al	76,39	74,55	83	30	40	58	—	8	30	0,392	64,64
40 T10/25-2	25	6F	Al	79,58	77,70	83	30	40	60	—	8	30	0,422	68,16
40 T10/26-2	26	6F	Al	82,76	80,90	87	30	40	60	—	8	30	0,477	71,68
40 T10/27-2	27	6F	Al	85,95	84,10	91	30	40	60	—	8	30	0,536	74,40
40 T10/28-2	28	6F	Al	89,13	87,25	93	30	40	60	—	8	30	0,540	77,28
40 T10/30-2	30	6F	Al	95,49	93,65	97	30	40	60	—	8	30	0,640	85,12
40 T10/32-2	32	6F	Al	101,86	100,00	106	30	40	65	—	10	32	0,693	97,60
40 T10/36-2	36	6F	Al	114,59	112,75	119	30	40	70	—	10	35	0,873	113,76
40 T10/40-2	40	6F	Al	127,32	125,45	131	30	40	80	—	10	40	1,067	143,36
40 T10/44-0	44	6	Al	140,06	138,20	—	30	40	88	—	10	46	1,350	156,16
40 T10/48-0	48	6	Al	152,78	150,95	—	30	40	95	—	16	48	1,516	174,72
40 T10/60-0	60	6	Al	190,98	189,10	—	30	40	110	—	16	60	2,339	226,88

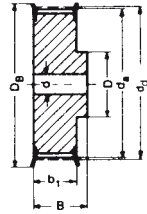

Ausf. Type 6F

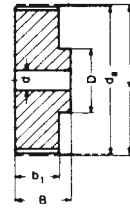

Ausf. Type 6

Profil Profile T10 – Teilung Pitch 10 mm für Riemenbreite for belt width 32 mm

Bezeichnung Part No.	Anzahl der Zähne No. of teeth	Aus- führung Type	Material	d _d (mm)	d _a (mm)	D _B (mm)	b ₁ (mm)	B (mm)	D (mm)	D _i (mm)	Vor- bohrung Pilot bore d (mm)	Fertig- bohrung Finished bore d _{max} (mm)	Gewicht Weight (≈ kg)	Fr. Stück each
47 T10/18-2	18	6F	Al	57,29	55,45	60	37	47	40	—	10	22	0,253	54,88
47 T10/19-2	19	6F	Al	60,48	58,60	66	37	47	44	—	10	22	0,286	60,64
47 T10/20-2	20	6F	Al	63,66	61,80	66	37	47	46	—	12	24	0,322	65,60
47 T10/22-2	22	6F	Al	70,03	68,15	75	37	47	52	—	12	28	0,393	72,64
47 T10/24-2	24	6F	Al	76,39	74,55	83	37	47	58	—	12	30	0,475	75,36
47 T10/25-2	25	6F	Al	79,58	77,70	83	37	47	60	—	12	30	0,527	80,16
47 T10/26-2	26	6F	Al	82,76	80,90	87	37	47	60	—	12	30	0,564	87,04
47 T10/27-2	27	6F	Al	85,95	84,10	91	37	47	60	—	12	30	0,602	88,80
47 T10/28-2	28	6F	Al	89,13	87,25	93	37	47	60	—	12	30	0,642	90,56
47 T10/30-2	30	6F	Al	95,49	93,65	97	37	47	60	—	12	30	0,740	95,68
47 T10/32-2	32	6F	Al	101,86	100,00	106	37	47	65	—	12	32	0,844	108,96
47 T10/36-2	36	6F	Al	114,59	112,75	119	37	47	70	—	16	35	1,083	129,44
47 T10/40-2	40	6F	Al	127,32	125,45	131	37	47	80	—	16	40	1,317	161,76
47 T10/44-0	44	6	Al	140,06	138,20	—	37	47	88	—	16	46	1,611	181,12
47 T10/48-0	48	6	Al	152,78	150,95	—	37	47	95	—	16	48	1,931	202,24
47 T10/60-0	60	6	Al	190,98	189,10	—	37	47	110	—	16	60	3,004	264,64

Profil Profile T10 – Teilung Pitch 10 mm für Riemenbreite for belt width 50 mm

66 T10/18-2	18	6F	Al	57,29	55,45	60	56	66	40	—	10	22	0,422	66,88
66 T10/19-2	19	6F	Al	60,48	58,60	66	56	66	44	—	10	22	0,466	71,68
66 T10/20-2	20	6F	Al	63,66	61,80	66	56	66	46	—	12	24	0,520	76,16
66 T10/22-2	22	6F	Al	70,03	68,15	75	56	66	52	—	12	28	0,570	84,48
66 T10/24-2	24	6F	Al	76,39	74,55	83	56	66	58	—	12	30	0,736	92,96
66 T10/25-2	25	6F	Al	79,58	77,70	83	56	66	60	—	12	30	0,766	96,32
66 T10/26-2	26	6F	Al	82,76	80,90	87	56	66	60	—	12	30	0,816	99,84
66 T10/27-2	27	6F	Al	85,95	84,10	91	56	66	60	—	12	30	0,946	104,00
66 T10/28-2	28	6F	Al	89,13	87,25	93	56	66	60	—	12	30	0,960	106,88
66 T10/30-2	30	6F	Al	95,49	93,65	97	56	66	60	—	12	30	1,169	117,92
66 T10/32-2	32	6F	Al	101,86	100,00	106	56	66	65	—	12	32	1,300	130,72
66 T10/36-2	36	6F	Al	114,59	112,75	119	56	66	70	—	16	35	1,637	166,72
66 T10/40-2	40	6F	Al	127,32	125,45	131	56	66	80	—	16	40	1,999	187,52
66 T10/44-0	44	6	Al	140,06	138,20	—	56	66	88	—	16	46	2,357	221,28
66 T10/48-0	48	6	Al	152,78	150,95	—	56	66	95	—	16	48	2,830	243,84
66 T10/60-0	60	6	Al	190,98	189,10	—	56	66	110	—	16	60	4,366	345,92

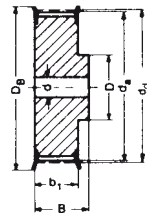

Ausf. Type 6F

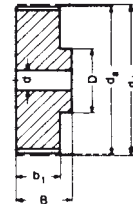

Ausf. Type 6

Profil Profile AT5 – Teilung Pitch 5 mm für Riemenbreite for belt width 10 mm

Bezeichnung Part No.	Anzahl der Zähne No. of teeth	Aus- führung Type	Material	d _d (mm)	d _a (mm)	D _B (mm)	b ₁ (mm)	B (mm)	D (mm)	Vor- bohrung Pilot bore d (mm)	Fertig- bohrung Finished bore d _{max} (mm)	Gewicht Weight (≈ kg)	Fr. Stück each
21 AT5/12-2	12	6F	Al	19,01	17,85	23,0	15	21	10	—	6	0,016	22,40
21 AT5/14-2	14	6F	Al	22,29	21,05	25,0	15	21	13	—	8	0,019	23,68
21 AT5/15-2	15	6F	Al	23,88	22,65	28,0	15	21	16	6	10	0,021	24,16
21 AT5/16-2	16	6F	Al	25,47	24,20	32,0	15	21	18	6	11	0,025	25,44
21 AT5/18-2	18	6F	Al	28,65	27,40	32,0	15	21	19	6	12	0,031	28,16
21 AT5/19-2	19	6F	Al	30,25	29,00	36,0	15	21	22	6	12	0,036	28,64
21 AT5/20-2	20	6F	Al	31,83	30,60	36,0	15	21	23	6	14	0,038	29,44
21 AT5/22-2	22	6F	Al	35,12	33,85	38,0	15	21	24	6	15	0,046	30,24
21 AT5/24-2	24	6F	Al	38,21	37,00	42,0	15	21	26	6	15	0,054	31,04
21 AT5/25-2	25	6F	Al	39,80	38,60	44,0	15	21	26	6	15	0,058	31,52
21 AT5/26-2	26	6F	Al	41,47	40,20	44,0	15	21	26	6	16	0,062	32,00
21 AT5/27-2	27	6F	Al	42,98	41,80	48,0	15	21	30	8	18	0,064	32,48
21 AT5/28-2	28	6F	Al	44,62	43,35	48,0	15	21	32	8	18	0,071	33,28
21 AT5/30-2	30	6F	Al	47,76	46,55	51,0	15	21	34	8	18	0,075	34,24
21 AT5/32-2	32	6F	Al	50,94	49,70	54,0	15	21	38	8	22	0,088	36,96
21 AT5/36-2	36	6F	Al	57,31	56,05	63,0	15	21	38	8	22	0,114	41,60
21 AT5/40-2	40	6F	Al	63,66	62,45	66,0	15	21	40	8	23	0,138	46,56
21 AT5/42-2	42	6F	Al	66,87	65,60	71,0	15	21	40	8	24	0,180	48,16
21 AT5/44-0	44	6	Al	70,07	68,80	—	15	21	45	8	26	0,185	48,80
21 AT5/48-0	48	6	Al	76,42	75,15	—	15	21	50	8	28	0,200	55,04
21 AT5/60-0	60	6	Al	95,52	94,25	—	15	21	65	8	35	0,307	72,80

Profil Profile AT5 – Teilung Pitch 5 mm für Riemenbreite for belt width 16 mm

27 AT5/12-2	12	6F	Al	19,01	17,85	23,0	21	27	10	—	6	0,022	24,16
27 AT5/14-2	14	6F	Al	22,29	21,05	25,0	21	27	13	—	8	0,026	24,64
27 AT5/15-2	15	6F	Al	23,88	22,65	28,0	21	27	16	6	10	0,029	25,44
27 AT5/16-2	16	6F	Al	25,47	24,20	32,0	21	27	18	6	11	0,035	27,04
27 AT5/18-2	18	6F	Al	28,65	27,40	32,0	21	27	19	6	12	0,043	29,44
27 AT5/19-2	19	6F	Al	30,25	29,00	36,0	21	27	22	6	12	0,049	30,24
27 AT5/20-2	20	6F	Al	31,83	30,60	36,0	21	27	23	6	14	0,053	31,52
27 AT5/22-2	22	6F	Al	35,12	33,85	38,0	21	27	24	6	15	0,054	32,16
27 AT5/24-2	24	6F	Al	38,21	37,00	42,0	21	27	26	6	15	0,076	32,64
27 AT5/25-2	25	6F	Al	39,80	38,60	44,0	21	27	26	6	15	0,081	33,92
27 AT5/26-2	26	6F	Al	41,47	40,20	44,0	21	27	26	6	16	0,085	34,88
27 AT5/27-2	27	6F	Al	42,98	41,80	48,0	21	27	30	8	18	0,090	36,16
27 AT5/28-2	28	6F	Al	44,62	43,35	48,0	21	27	32	8	18	0,092	36,96
27 AT5/30-2	30	6F	Al	47,76	46,55	51,0	21	27	34	8	18	0,105	39,52
27 AT5/32-2	32	6F	Al	50,94	49,70	54,0	21	27	38	8	22	0,123	41,12
27 AT5/36-2	36	6F	Al	57,31	56,05	63,0	21	27	38	8	22	0,160	47,04
27 AT5/40-2	40	6F	Al	63,66	62,45	66,0	21	27	40	8	23	0,193	53,76
27 AT5/42-2	42	6F	Al	66,87	65,60	71,0	21	27	40	8	24	0,205	56,96
27 AT5/44-0	44	6	Al	70,07	68,80	—	21	27	45	8	26	0,228	59,36
27 AT5/48-0	48	6	Al	76,42	75,15	—	21	27	50	8	28	0,280	62,88
27 AT5/60-0	60	6	Al	95,52	94,25	—	21	27	65	8	35	0,430	77,92

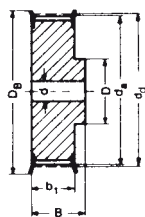

Ausf. Type 6F

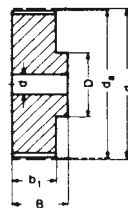

Ausf. Type 6

Profil Profile AT5 – Teilung Pitch 5 mm für Riemenbreite for belt width 25 mm

Bezeichnung Part No.	Anzahl der Zähne No. of teeth	Aus- führung Type	Material	d _d (mm)	d _a (mm)	D _B (mm)	b ₁ (mm)	B (mm)	D (mm)	Vor- bohrung Pilot bore d (mm)	Fertig- bohrung Finished bore d _{max} (mm)	Gewicht Weight (≈ kg)	Fr. Stück each
36 AT5/12-2	12	6F	Al	19,01	17,85	23,0	30	36	10	—	6	0,031	31,52
36 AT5/14-2	14	6F	Al	22,29	21,05	25,0	30	36	13	—	8	0,037	31,52
36 AT5/15-2	15	6F	Al	23,88	22,65	28,0	30	36	16	6	10	0,041	32,16
36 AT5/16-2	16	6F	Al	25,47	24,20	32,0	30	36	18	6	11	0,050	32,64
36 AT5/18-2	18	6F	Al	28,65	27,40	32,0	30	36	19	6	12	0,061	33,92
36 AT5/19-2	19	6F	Al	30,25	29,00	36,0	30	36	22	6	12	0,070	34,24
36 AT5/20-2	20	6F	Al	31,83	30,60	36,0	30	36	23	6	14	0,076	34,88
36 AT5/22-2	22	6F	Al	35,12	33,85	38,0	30	36	24	6	15	0,080	37,76
36 AT5/24-2	24	6F	Al	38,21	37,00	42,0	30	36	26	8	15	0,109	38,24
36 AT5/25-2	25	6F	Al	39,80	38,60	44,0	30	36	26	8	15	0,116	39,36
36 AT5/26-2	26	6F	Al	41,47	40,20	44,0	30	36	26	8	16	0,120	40,64
36 AT5/27-2	27	6F	Al	42,98	41,80	48,0	30	36	30	8	18	0,128	41,92
36 AT5/28-2	28	6F	Al	44,62	43,35	48,0	30	36	32	8	18	0,135	43,20
36 AT5/30-2	30	6F	Al	47,76	46,55	51,0	30	36	34	8	18	0,150	44,16
36 AT5/32-2	32	6F	Al	50,94	49,70	54,0	30	36	38	8	22	0,176	47,04
36 AT5/36-2	36	6F	Al	57,31	56,05	63,0	30	36	38	8	22	0,230	52,00
36 AT5/40-2	40	6F	Al	63,66	62,45	66,0	30	36	40	8	23	0,276	59,68
36 AT5/42-2	42	6F	Al	66,87	65,60	71,0	30	36	40	8	24	0,284	63,84
36 AT5/44-0	44	6	Al	70,07	68,80	—	30	36	45	8	26	0,315	67,20
36 AT5/48-0	48	6	Al	76,42	75,15	—	30	36	50	8	28	0,400	75,04
36 AT5/60-0	60	6	Al	95,52	94,25	—	30	36	65	8	35	0,614	93,44

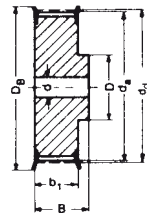

Ausf. Type 6F

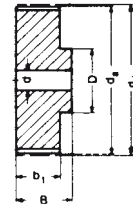

Ausf. Type 6

Profil Profile AT10 – Teilung Pitch 10 mm für Riemenbreite for belt width 16 mm

Bezeichnung Part No.	Anzahl der Zähne No. of teeth	Aus- führung Type	Material	d _d (mm)	d _a (mm)	D _B (mm)	b ₁ (mm)	B (mm)	D (mm)	Vor- bohrung Pilot bore d (mm)	Fertig- bohrung Finished bore d _{max} (mm)	Gewicht Weight (≈ kg)	Fr. Stück each
31 AT10/15-2	15	6F	Al	47,75	45,90	51	21	31	32	8	18	0,116	35,68
31 AT10/16-2	16	6F	Al	50,93	49,05	54	21	31	35	8	20	0,134	38,88
31 AT10/18-2	18	6F	Al	57,29	55,45	60	21	31	40	8	22	0,167	45,12
31 AT10/19-2	19	6F	Al	60,48	58,60	66	21	31	44	8	22	0,184	50,24
31 AT10/20-2	20	6F	Al	63,66	61,80	66	21	31	46	8	24	0,208	52,64
31 AT10/22-2	22	6F	Al	70,03	68,15	75	21	31	52	8	28	0,253	59,84
31 AT10/24-2	24	6F	Al	76,39	74,55	83	21	31	58	8	30	0,288	66,40
31 AT10/25-2	25	6F	Al	79,58	77,70	83	21	31	60	8	30	0,310	68,32
31 AT10/26-2	26	6F	Al	82,76	80,90	87	21	31	60	8	30	0,357	72,32
31 AT10/27-2	27	6F	Al	85,95	84,10	91	21	31	60	8	30	0,364	78,72
31 AT10/28-2	28	6F	Al	89,13	87,25	93	21	31	60	8	30	0,401	80,16
31 AT10/30-2	30	6F	Al	95,49	93,65	97	21	31	60	8	30	0,441	91,84
31 AT10/32-2	32	6F	Al	101,86	100,00	106	21	31	65	10	32	0,493	103,68
31 AT10/36-2	36	6F	Al	114,59	112,75	119	21	31	70	10	35	0,623	119,52
31 AT10/40-2	40	6F	Al	127,32	125,45	131	21	31	80	10	40	0,767	150,24
31 AT10/44-0	44	6	Al	140,06	138,20	—	21	31	88	10	46	0,993	166,24
31 AT10/48-0	48	6	Al	152,78	150,95	—	21	31	95	16	48	1,090	184,64
31 AT10/60-0	60	6	Al	190,98	189,10	—	21	31	110	16	60	1,710	262,08

Profil Profile AT10 – Teilung Pitch 10 mm für Riemenbreite for belt width 25 mm

40 AT10/15-2	15	6F	Al	47,75	45,90	51	30	40	32	8	18	0,152	43,20
40 AT10/16-2	16	6F	Al	50,93	49,05	54	30	40	35	8	20	0,176	44,96
40 AT10/18-2	18	6F	Al	57,29	55,45	60	30	40	40	8	22	0,224	54,88
40 AT10/19-2	19	6F	Al	60,48	58,60	66	30	40	44	8	22	0,247	60,48
40 AT10/20-2	20	6F	Al	63,66	61,80	66	30	40	46	8	24	0,276	63,84
40 AT10/22-2	22	6F	Al	70,03	68,15	75	30	40	52	8	28	0,337	72,48
40 AT10/24-2	24	6F	Al	76,39	74,55	83	30	40	58	8	30	0,392	77,28
40 AT10/25-2	25	6F	Al	79,58	77,70	83	30	40	60	8	30	0,422	80,80
40 AT10/26-2	26	6F	Al	82,76	80,90	87	30	40	60	8	30	0,477	87,36
40 AT10/27-2	27	6F	Al	85,95	84,10	91	30	40	60	8	30	0,536	90,88
40 AT10/28-2	28	6F	Al	89,13	87,25	93	30	40	60	8	30	0,540	94,72
40 AT10/30-2	30	6F	Al	95,49	93,65	97	30	40	60	8	30	0,640	104,00
40 AT10/32-2	32	6F	Al	101,86	100,00	106	30	40	65	10	32	0,693	119,52
40 AT10/36-2	36	6F	Al	114,59	112,75	119	30	40	70	10	35	0,873	138,88
40 AT10/40-2	40	6F	Al	127,32	125,45	131	30	40	80	10	40	1,067	174,72
40 AT10/44-0	44	6	Al	140,06	138,20	—	30	40	88	10	46	1,350	192,64
40 AT10/48-0	48	6	Al	152,78	150,95	—	30	40	95	16	48	1,516	215,52
40 AT10/60-0	60	6	Al	190,98	189,10	—	30	40	110	16	60	2,339	281,44

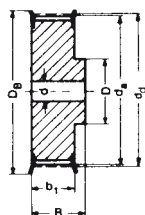

Ausf. Type 6F

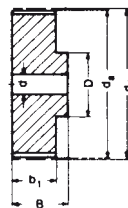

Ausf. Type 6

Profil Profile AT10 – Teilung Pitch 10 mm für Riemenbreite for belt width 32 mm

Bezeichnung Part No.	Anzahl der Zähne No. of teeth	Aus- führung Type	Material	d _d (mm)	d _a (mm)	D _B (mm)	b ₁ (mm)	B (mm)	D (mm)	Vor- bohrung Pilot bore d (mm)	Fertig- bohrung Finished bore d _{max} (mm)	Gewicht Weight (≈ kg)	Fr. Stück each
47 AT10/18-2	18	6F	Al	57,29	55,45	60	37	47	40	10	22	0,253	62,08
47 AT10/19-2	19	6F	Al	60,48	58,60	66	37	47	44	10	22	0,286	68,32
47 AT10/20-2	20	6F	Al	63,66	61,80	66	37	47	46	12	24	0,322	73,92
47 AT10/22-2	22	6F	Al	70,03	68,15	75	37	47	52	12	28	0,393	87,04
47 AT10/24-2	24	6F	Al	76,39	74,55	83	37	47	58	12	30	0,475	92,32
47 AT10/25-2	25	6F	Al	79,58	77,70	83	37	47	60	12	30	0,527	94,56
47 AT10/26-2	26	6F	Al	82,76	80,90	87	37	47	60	12	30	0,564	104,48
47 AT10/27-2	27	6F	Al	85,95	84,10	91	37	47	60	12	30	0,602	108,16
47 AT10/28-2	28	6F	Al	89,13	87,25	93	37	47	60	12	30	0,642	111,04
47 AT10/30-2	30	6F	Al	95,49	93,65	97	37	47	60	12	30	0,740	116,64
47 AT10/32-2	32	6F	Al	101,86	100,00	106	37	47	65	12	32	0,844	133,12
47 AT10/36-2	36	6F	Al	114,59	112,75	119	37	47	70	16	35	1,083	157,44
47 AT10/40-2	40	6F	Al	127,32	125,45	131	37	47	80	16	40	1,317	198,56
47 AT10/44-0	44	6	Al	140,06	138,20	—	37	47	88	16	46	1,611	223,20
47 AT10/48-0	48	6	Al	152,78	150,95	—	37	47	95	16	48	1,931	246,56
47 AT10/60-0	60	6	Al	190,98	189,10	—	37	47	110	16	60	3,004	324,16

Profil Profile AT10 – Teilung Pitch 10 mm für Riemenbreite for belt width 50 mm

66 AT10/18-2	18	6F	Al	57,29	55,45	60	56	66	40	10	22	0,422	75,36
66 AT10/19-2	19	6F	Al	60,48	58,60	66	56	66	44	10	22	0,466	81,76
66 AT10/20-2	20	6F	Al	63,66	61,80	66	56	66	46	12	24	0,520	88,00
66 AT10/22-2	22	6F	Al	70,03	68,15	75	56	66	52	12	28	0,570	100,48
66 AT10/24-2	24	6F	Al	76,39	74,55	83	56	66	58	12	30	0,736	113,12
66 AT10/25-2	25	6F	Al	79,58	77,70	83	56	66	60	12	30	0,766	113,28
66 AT10/26-2	26	6F	Al	82,76	80,90	87	56	66	60	12	30	0,816	122,56
66 AT10/27-2	27	6F	Al	85,95	84,10	91	56	66	60	12	30	0,946	126,72
66 AT10/28-2	28	6F	Al	89,13	87,25	93	56	66	60	12	30	0,960	130,24
66 AT10/30-2	30	6F	Al	95,49	93,65	97	56	66	60	12	30	1,169	148,32
66 AT10/32-2	32	6F	Al	101,86	100,00	106	56	66	65	12	32	1,300	164,64
66 AT10/36-2	36	6F	Al	114,59	112,75	119	56	66	70	16	35	1,637	204,16
66 AT10/40-2	40	6F	Al	127,32	125,45	131	56	66	80	16	40	1,999	234,88
66 AT10/44-0	44	6	Al	140,06	138,20	—	56	66	88	16	46	2,357	273,76
66 AT10/48-0	48	6	Al	152,78	150,95	—	56	66	95	16	48	2,830	302,88
66 AT10/60-0	60	6	Al	190,98	189,10	—	56	66	110	16	60	4,366	425,12

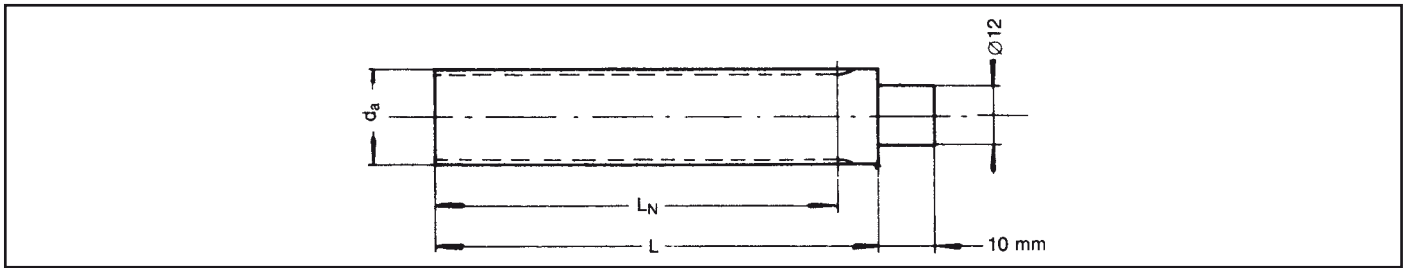

Profil Profile XL – Teilung pitch 5,08 mm (1/5")

Bezeichnung Designation	Anzahl der Zähne No. of teeth	Material	dd (mm)	da (mm)	LN (mm)	L (mm)	Fr. Stück each
10 XL 125•	10	St	16,17	15,66	125	140	auf Anfrage on request
11 XL 125•	11	St	17,79	17,28	125	140	
12 XL 125•	12	St	19,40	18,89	125	140	
13 XL 125•	13	St	21,02	20,51	125	140	
14 XL 132•	14	St	22,64	22,13	132	140	
15 XL 132•	15	St	24,26	23,75	132	140	
16 XL 140•	16	St	25,87	25,36	140	140	
17 XL 140•	17	St	27,49	26,98	140	140	
18 XL 140•	18	St	29,11	28,60	140	140	
19 XL 140•	19	St	30,72	30,21	140	140	
20 XL 140•	20	St	32,34	31,83	140	140	
21 XL 160•	21	St	33,96	33,45	160	160	
22 XL 160•	22	St	35,57	35,06	160	160	
23 XL 160•	23	St	37,19	36,68	160	160	
24 XL 160•	24	St	38,81	38,30	160	160	
25 XL 160•	25	St	40,43	39,92	160	160	
26 XL 160•	26	St	42,04	41,53	160	160	
27 XL 160•	27	St	43,66	43,15	160	160	
28 XL 160•	28	St	45,28	44,77	160	160	
29 XL 160•	29	St	46,89	46,38	160	160	
30 XL 160•	30	St	48,51	48,00	160	160	
32 XL 160•	32	Al	51,74	51,23	160	160	
33 XL 160•	33	Al	53,36	52,76	160	160	
34 XL 160•	34	Al	54,98	54,47	160	160	
35 XL 160•	35	Al	56,60	56,09	160	160	
36 XL 160•	36	Al	58,21	57,70	160	160	
38 XL 160•	38	Al	61,45	60,94	160	160	
39 XL 160•	39	Al	63,06	62,55	160	160	
40 XL 160•	40	Al	64,68	64,17	160	160	
41 XL 160•	41	Al	66,30	65,79	160	160	
42 XL 160•	42	Al	67,91	67,40	160	160	
43 XL 160•	43	Al	69,53	69,02	160	160	
44 XL 160•	44	Al	71,15	70,64	160	160	
48 XL 160•	48	Al	77,62	77,11	160	160	
56 XL 160•	56	Al	90,55	90,04	160	160	
60 XL 160•	60	Al	97,02	96,51	160	160	
72 XL 160•	72	Al	116,43	115,92	160	160	

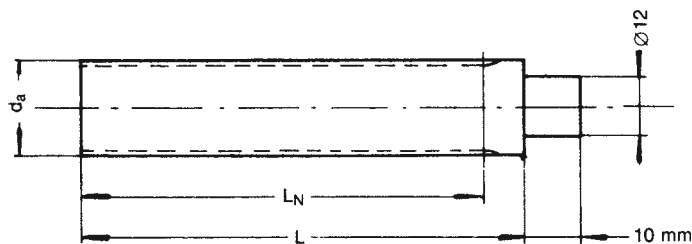

Profil Profile L – Teilung *pitch* 9,525 mm ($3/8''$)

Bezeichnung <i>Designation</i>	Anzahl der Zähne <i>No. of teeth</i>	Material	d_d (mm)	d_a (mm)	L_N (mm)	L (mm)	Fr. Stück <i>each</i>
10 L 140•	10	St	30,32	29,56	140	140	auf Anfrage on request
11 L 140•	11	St	33,35	32,59	140	140	
12 L 160•	12	St	36,38	35,62	160	160	
13 L 160•	13	St	39,41	38,65	160	160	
14 L 160•	14	St	42,45	41,68	160	160	
15 L 160•	15	St	45,48	44,72	160	160	
16 L 160•	16	St	48,51	47,75	160	160	
17 L 160•	17	St	51,54	50,78	160	160	
18 L 160•	18	St	54,57	53,81	160	160	
19 L 160•	19	St	57,61	56,84	160	160	
20 L 160•	20	St	60,64	59,88	160	160	
21 L 160•	21	St	63,67	62,91	160	160	
22 L 160•	22	St	66,70	65,94	160	160	
23 L 160•	23	St	69,73	68,97	160	160	
24 L 160•	24	St	72,77	72,00	160	160	
27 L 160•	27	St	81,86	81,10	160	160	
30 L 160•	30	St	90,96	90,20	160	160	

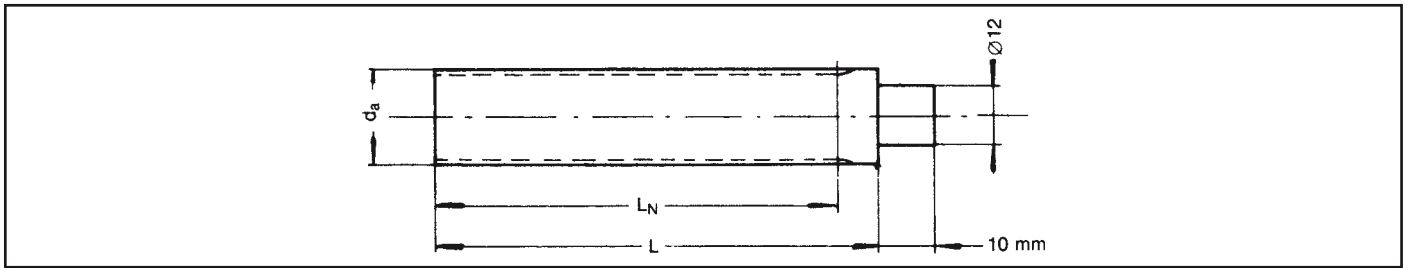

Profil Profile T5 – Teilung pitch 5 mm

Bezeichnung Designation	Anzahl der Zähne No. of teeth	Material	d _d (mm)	d _a (mm)	L _N (mm)	L (mm)	Fr. Stück each
125 T5- 10•	10	Al	15,92	15,05	125	140	auf Anfrage on request
125 T5- 11•	11	Al	17,51	16,65	125	140	
125 T5- 12•	12	Al	19,01	18,25	125	140	
125 T5- 13•	13	Al	20,70	19,85	125	140	
132 T5- 14•	14	Al	22,29	21,45	132	140	
132 T5- 15•	15	Al	23,88	23,05	132	140	
140 T5- 16•	16	Al	25,47	24,60	140	140	
140 T5- 17•	17	Al	27,06	26,20	140	140	
140 T5- 18•	18	Al	28,65	27,80	140	140	
140 T5- 19•	19	Al	30,25	29,40	140	140	
160 T5- 20•	20	Al	31,83	31,00	160	160	
160 T5- 21•	21	Al	33,43	32,70	160	160	
160 T5- 22•	22	Al	35,12	34,25	160	160	
160 T5- 23•	23	Al	36,62	35,85	160	160	
160 T5- 24•	24	Al	38,21	37,40	160	160	
160 T5- 25•	25	Al	39,80	39,00	160	160	
160 T5- 26•	26	Al	41,47	40,60	160	160	
160 T5- 27•	27	Al	42,98	42,20	160	160	
160 T5- 28•	28	Al	44,62	43,75	160	160	
160 T5- 29•	29	Al	46,17	45,35	160	160	
160 T5- 30•	30	Al	47,76	46,95	160	160	
160 T5- 32•	32	Al	50,94	50,10	160	160	
160 T5- 34•	34	Al	54,13	53,25	160	160	
160 T5- 35•	35	Al	55,72	54,85	160	160	
160 T5- 36•	36	Al	57,31	56,45	160	160	
160 T5- 37•	37	Al	58,90	58,06	160	160	
160 T5- 38•	38	Al	60,50	59,65	160	160	
160 T5- 40•	40	Al	63,66	62,85	160	160	
160 T5- 42•	42	Al	66,87	66,00	160	160	
160 T5- 44•	44	Al	70,07	69,20	160	160	
160 T5- 45•	45	Al	71,64	70,80	160	160	
160 T5- 46•	46	Al	73,23	72,40	160	160	
160 T5- 48•	48	Al	76,42	75,55	160	160	
160 T5- 50•	50	Al	79,60	78,75	160	160	
160 T5- 60•	60	Al	95,52	94,65	160	160	
160 T5- 72•	72	Al	114,62	113,75	160	160	
160 T5- 80•	80	Al	127,36	126,48	160	160	
160 T5- 90•	90	Al	143,28	142,40	160	160	
160 T5-100•	100	Al	159,20	158,31	160	160	

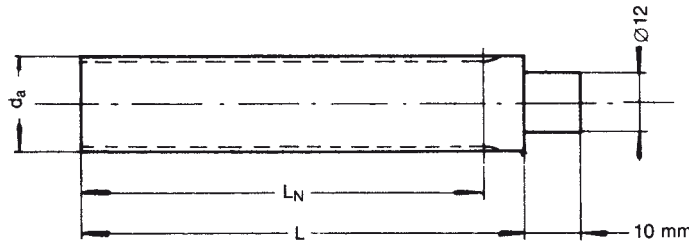

Profil Profile T10 – Teilung pitch 10 mm

Bezeichnung Designation	Anzahl der Zähne No. of teeth	Material	d_d (mm)	d_a (mm)	L_N (mm)	L (mm)	Fr. Stück each
140 T10-10•	10	Al	31,83	29,98	140	140	auf Anfrage on request
140 T10-11•	11	Al	35,01	33,16	140	140	
140 T10-12•	12	Al	38,20	36,35	140	140	
140 T10-13•	13	Al	41,38	39,50	140	140	
160 T10-14•	14	Al	44,56	42,70	160	160	
160 T10-15•	15	Al	47,75	45,90	160	160	
160 T10-16•	16	Al	50,93	49,05	160	160	
160 T10-17•	17	Al	54,11	52,25	160	160	
160 T10-18•	18	Al	57,29	55,45	160	160	
160 T10-19•	19	Al	60,48	58,60	160	160	
160 T10-20•	20	Al	63,66	61,60	160	160	
160 T10-21•	21	Al	66,84	65,00	160	160	
160 T10-22•	22	Al	70,03	68,15	160	160	
160 T10-23•	23	Al	73,20	71,35	160	160	
160 T10-24•	24	Al	76,39	74,55	160	160	
160 T10-26•	26	Al	82,76	80,90	160	160	
160 T10-28•	28	Al	89,13	87,25	160	160	
160 T10-30•	30	Al	95,49	93,65	160	160	
160 T10-32•	32	Al	101,86	100,00	160	160	
160 T10-34•	34	Al	108,22	106,40	160	160	
160 T10-36•	36	Al	114,59	112,75	160	160	
160 T10-38•	38	Al	120,95	119,10	160	160	
160 T10-40•	40	Al	127,32	125,45	160	160	
160 T10-45•	45	Al	143,24	141,40	160	160	
160 T10-48•	48	Al	152,78	150,95	160	160	
160 T10-60•	60	Al	190,98	189,10	160	160	
160 T10-72•	72	Al	229,18	227,29	160	160	

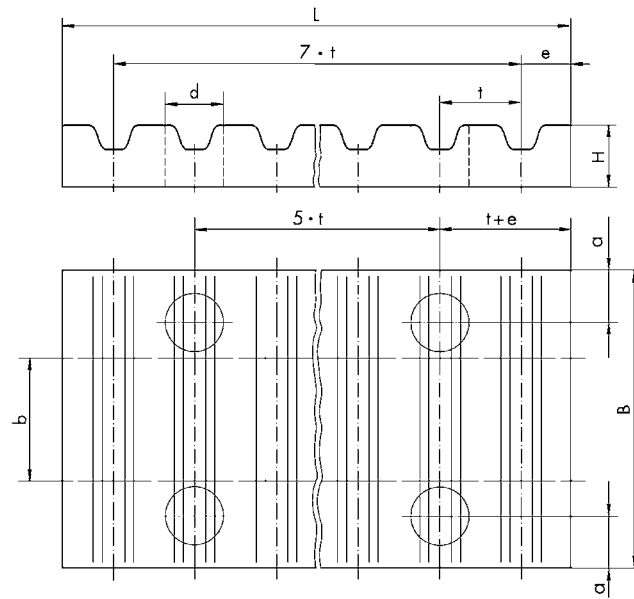

Artikel- Bezeichnung Designation	Teilung Pitch t (mm)	Riemenbreite Belt width b (mm)	Material	B (mm)	a (mm)	L (mm)	e (mm)	H (mm)	d (mm)	Gewicht Weight ≈ (kg)	Fr. Stück each
CP-XL 025	5,080	6,35	Al	25,5	6,0	42,5	3,5	8,0	5,5	0,020	32,48
CP-XL 037	5,080	9,53	Al	28,5	6,0	42,5	3,5	8,0	5,5	0,025	32,80
CP-XL 050	5,080	12,70	Al	32,0	6,0	42,5	3,5	8,0	5,5	0,027	39,68
CP-XL 075	5,080	19,05	Al	38,0	6,0	42,5	3,5	8,0	5,5	0,032	46,56
CP-XL 100•	5,080	25,40	Al	45,0	6,0	42,5	3,5	8,0	5,5	0,038	57,76
CP-L 037	9,525	9,53	Al	36,0	8,0	76,6	5,0	15,0	9,0	0,095	40,80
CP-L 050	9,525	12,70	Al	39,0	8,0	76,6	5,0	15,0	9,0	0,104	43,20
CP-L 075	9,525	19,05	Al	45,0	8,0	76,6	5,0	15,0	9,0	0,121	48,00
CP-L 100	9,525	25,40	Al	51,5	8,0	76,6	5,0	15,0	9,0	0,140	53,12
CP-L 150	9,525	38,10	Al	64,0	8,0	76,6	5,0	15,0	9,0	0,177	65,12
CP-L 200	9,525	50,80	Al	77,0	8,0	76,6	5,0	15,0	9,0	0,215	76,00
CP-H 050	12,700	12,70	Al	45,0	10,0	106,9	9,0	22,0	11,0	0,050	51,36
CP-H 075	12,700	19,05	Al	51,0	10,0	106,9	9,0	22,0	11,0	0,075	53,28
CP-H 100	12,700	25,40	Al	57,5	10,0	106,9	9,0	22,0	11,0	0,100	57,76
CP-H 150	12,700	38,10	Al	70,0	10,0	106,9	9,0	22,0	11,0	0,150	68,80
CP-H 200	12,700	50,80	Al	83,0	10,0	106,9	9,0	22,0	11,0	0,200	81,12
CP-H 300	12,700	76,20	Al	108,0	10,0	106,9	9,0	22,0	11,0	0,300	99,36
CP-H 400•	12,700	101,60	Al	134,0	10,0	106,9	9,0	22,0	11,0	0,400	118,56
CP-5M 06	5,000	6,00	Al	25,0	6,0	41,8	3,2	8,0	5,5	0,015	32,32
CP-5M 09	5,000	9,00	Al	28,0	6,0	41,8	3,2	8,0	5,5	0,018	32,64
CP-5M 15	5,000	15,00	Al	34,0	6,0	41,8	3,2	8,0	5,5	0,022	33,12
CP-5M 25	5,000	25,00	Al	44,0	6,0	41,8	3,2	8,0	5,5	0,030	33,76
CP-8M 10	8,000	10,00	Al	35,0	8,0	66,0	5,0	15,0	9,0	0,075	44,16
CP-8M 15	8,000	15,00	Al	40,0	8,0	66,0	5,0	15,0	9,0	0,085	44,80
CP-8M 20	8,000	20,00	Al	45,0	8,0	66,0	5,0	15,0	9,0	0,100	45,92
CP-8M 30	8,000	30,00	Al	55,0	8,0	66,0	5,0	15,0	9,0	0,120	47,68
CP-8M 50	8,000	50,00	Al	75,0	8,0	66,0	5,0	15,0	9,0	0,170	52,80
CP-8M 85	8,000	85,00	Al	110,0	8,0	66,0	5,0	15,0	9,0	0,250	81,60
CP-14M 25	14,000	25,00	Al	56,0	10,0	116,0	9,0	22,0	11,0	0,315	108,32
CP-14M 40	14,000	40,00	Al	71,0	10,0	116,0	9,0	22,0	11,0	0,405	114,72
CP-14M 55	14,000	55,00	Al	86,0	10,0	116,0	9,0	22,0	11,0	0,495	123,36
CP-14M 85	14,000	85,00	Al	116,0	10,0	116,0	9,0	22,0	11,0	0,860	141,28
CP-14M 115•	14,000	115,00	Al	146,0	10,0	116,0	9,0	22,0	11,0	1,195	159,04

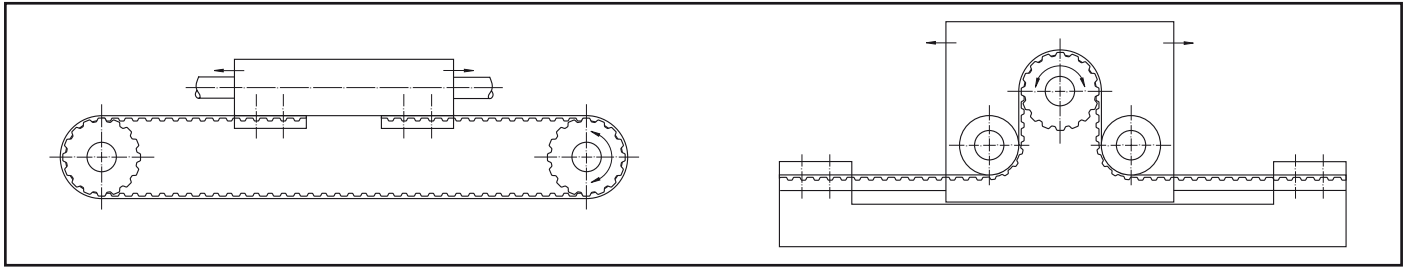

Artikel- Bezeichnung Designation	Teilung <i>Pitch</i> t (mm)	Riemenbreite Belt width b (mm)	Material	B (mm)	a (mm)	L (mm)	e (mm)	H (mm)	d (mm)	Gewicht Weight ≈ (kg)	Fr. Stück each
CP- 6 T5	5,000	6,00	Al	25,0	6,0	41,8	3,2	8,0	5,5	0,020	32,32
CP- 10 T5	5,000	10,00	Al	29,0	6,0	41,8	3,2	8,0	5,5	0,025	32,64
CP- 16 T5	5,000	16,00	Al	35,0	6,0	41,8	3,2	8,0	5,5	0,030	33,12
CP- 25 T5	5,000	25,00	Al	44,0	6,0	41,8	3,2	8,0	5,5	0,036	33,76
CP- 32 T5	5,000	32,00	Al	51,0	6,0	41,8	3,2	8,0	5,5	0,042	40,80
CP- 50 T5•	5,000	50,00	Al	69,0	6,0	41,8	3,2	8,0	5,5	0,051	48,00
CP- 16 T10	10,000	16,00	Al	41,0	8,0	80,0	5,0	15,0	9,0	0,115	44,32
CP- 25 T10	10,000	25,00	Al	50,0	8,0	80,0	5,0	15,0	9,0	0,140	51,36
CP- 32 T10	10,000	32,00	Al	57,0	8,0	80,0	5,0	15,0	9,0	0,160	54,08
CP- 50 T10	10,000	50,00	Al	75,0	8,0	80,0	5,0	15,0	9,0	0,215	59,20
CP- 75 T10•	10,000	75,00	Al	100,0	8,0	80,0	5,0	15,0	9,0	0,290	70,88
CP-100 T10•	10,000	100,00	Al	125,0	8,0	80,0	5,0	15,0	9,0	0,370	86,56
CP- 25 T20	20,000	25,00	Al	56,0	10,0	160,0	10,0	20,0	11,0	0,385	151,68
CP- 32 T20	20,000	32,00	Al	65,0	10,0	160,0	10,0	20,0	11,0	0,450	165,92
CP- 50 T20	20,000	50,00	Al	81,0	10,0	160,0	10,0	20,0	11,0	0,570	187,84
CP- 75 T20	20,000	75,00	Al	106,0	10,0	160,0	10,0	20,0	11,0	0,755	253,44
CP-100 T20•	20,000	100,00	Al	132,0	10,0	160,0	10,0	20,0	11,0	0,940	310,24
CP- 6 AT5	5,000	6,00	Al	25,0	6,0	41,8	3,2	8,0	5,5	0,016	49,44
CP- 10 AT5	5,000	10,00	Al	29,0	6,0	41,8	3,2	8,0	5,5	0,019	50,72
CP- 16 AT5	5,000	16,00	Al	35,0	6,0	41,8	3,2	8,0	5,5	0,024	52,32
CP- 25 AT5	5,000	25,00	Al	44,0	6,0	41,8	3,2	8,0	5,5	0,031	55,20
CP- 32 AT5	5,000	32,00	Al	51,0	6,0	41,8	3,2	8,0	5,5	0,036	57,92
CP- 50 AT5•	5,000	50,00	Al	61,0	6,0	41,8	3,2	8,0	5,5	0,043	61,60
CP- 16 AT10	10,000	16,00	Al	41,0	8,0	80,0	5,0	15,0	9,0	0,110	57,92
CP- 25 AT10	10,000	25,00	Al	50,0	8,0	80,0	5,0	15,0	9,0	0,135	66,72
CP- 32 AT10	10,000	32,00	Al	57,0	8,0	80,0	5,0	15,0	9,0	0,155	70,40
CP- 50 AT10	10,000	50,00	Al	75,0	8,0	80,0	5,0	15,0	9,0	0,205	77,12
CP- 75 AT10	10,000	75,00	Al	100,0	8,0	80,0	5,0	15,0	9,0	0,280	93,60
CP-100 AT10•	10,000	100,00	Al	125,0	8,0	80,0	5,0	15,0	9,0	0,350	112,48
CP- 25 AT20	20,000	25,00	Al	56,0	10,0	160,0	10,0	20,0	11,0	0,385	189,60
CP- 32 AT20	20,000	32,00	Al	65,0	10,0	160,0	10,0	20,0	11,0	0,450	205,60
CP- 50 AT20	20,000	50,00	Al	81,0	10,0	160,0	10,0	20,0	11,0	0,570	235,68
CP- 75 AT20	20,000	75,00	Al	106,0	10,0	160,0	10,0	20,0	11,0	0,755	317,28
CP-100 AT20•	20,000	100,00	Al	132,0	10,0	160,0	10,0	20,0	11,0	0,940	391,68



optibelt TV Anschraubnaben – Bolt on hubs													
Bezeichnung Designation	Material	Taper- Buchse Taper bushing	D _A (mm)	D _T (mm)	D + 0/- 0,1 (mm)	D _K (mm)	B (mm)	b (mm)	Z (mm)	B _M (mm)	d (mm)	Gewicht o. Buchse Weight without bushing (≈ kg)	Fr. Stück ohne Buchse each without bushing
SM 12	GG	1210	180	135	90	75	25	6,5	2,5	11,5	6 x 7,5	1,5	76,64
SM 16	GG	1615	200	150	110	85	38	7,5	2,5	12,5	6 x 7,5	3,0	89,12
SM 20	GG	2012	270	190	140	110	32	8,5	2,5	13,5	6 x 9,5		128,00
SM 25	GG	2517	340	240	170	125	45	9,5	2,5	14,5	8 x 11,5	7,6	200,32
SM 30-1	GG	3020	430	300	220	160	51	13,5	2,5	18,5	8 x 13,5	16,6	287,20
SM 30-2	GG	3020	485	340	250	160	51	13,5	2,5	18,5	8 x 13,5	20,5	452,00

optibelt TV Einschweißnaben Type WM – Weld on hubs type WM											
Bezeichnung Designation	Material	Taper- Buchse Taper bushing	D _A (mm)	D + 0/- 0,05 (mm)	D _K (mm)	B + 0,5/- 0,05 (mm)	b ₁ (mm)	b ₂ (mm)	Gewicht ohne Buchse Weight without bushing (≈ kg)	Fr. Stück ohne Buchse each without bushing	
WM 1210	St	1210	70	60	58	25	9	10	0,3	57,28	
WM 1615	St	1615	83	70	68	38	16	11	0,6	70,56	
WM 2012	St	2012	95	90	88	32	12	12	0,7	74,24	
WM 2517	St	2517	127	110	108	44	19	13	1,8	92,48	
WM 3030	St	3030	152	130	125	76	25	19	3,5	165,12	
WM 3535	St	3535	184	155	151	89	32	25	10,0	294,24	
WM 4040	St	4040	225	195	187	102	32	32	13,2	421,76	
WM 4545	St	4545	254	220	213	115	38	38	20,1	655,84	
WM 5050	St	5050	276	242	228	127	38	38	25,4	1.017,28	

optibelt TV Einschweißnaben Type WH – Weld on hubs type WH											
Bezeichnung Designation	Material	Taper- Buchse Taper bushing	D _A (mm)	D + 0/- 0,05 (mm)	D _K (mm)	B + 0,5/- 0,05 (mm)	b ₁ (mm)	b ₂ (mm)	Gewicht ohne Buchse Weight without bushing (≈ kg)	Fr. Stück ohne Buchse each without bushing	
WH 1210	St	1210	70	65	64,5	25	9	10	0,3	57,28	
WH 1610	St	1610	80	75	74,5	25	9	10		70,56	
WH 2012	St	2012	95	90	89,5	32	12	12		74,24	
WH 2517	St	2517	115	110	109,5	44	19	15		92,48	
WH 3020	St	3020	145	140	139,5	50	19	15	2,7	165,12	
WH 3525	St	3525	190	180	179,5	65	25	25		228,64	
WH 3535	St	3535	190	180	179,5	89	32	25	10,0	294,24	
WH 4040	St	4040	200	190	189,5	101	32	30		421,76	
WH 4545	St	4545	210	200	199,5	115	40	30		655,84	
WH 5050	St	5050	230	220	219,5	127	40	35		1.017,28	

Taper-Buchse Taper bushing	1210	1610	1615	2012	2517	3020	3030	3525	3535	4040	4545	5050
Bohrung d ₂ (mm) von ... bis ... Bore d ₂ (mm) from ... to ...	11-32	14-42	14-42	14-50	16-60	25-75	35-75	35-90	35-90	40-100	44-110	70-125
Fr./Stück each	18,40	20,80	23,04	24,64	37,60	50,24	66,08	102,56	127,04	178,56	227,20	347,20

Bohrungsdurchmesser d₂ siehe Seite 3.
Bore diameters d₂ see page 3.

Weitere Abmessungen auf Anfrage.
Further sizes on request.

GG = Grauguss
GG = Cast iron

St = Stahl
St = Steel

Fertigungstechnische Änderungen vorbehalten.
We reserve the right to make technical changes.

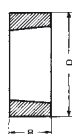

Bezeichnung Part No.	Material	Taper- Buchse Taper bushing	D (mm)	B (mm)	Nut- querschnitt Keyway dimensions b x h (mm)	Minimaler Nabendurchmesser der Scheibe Minimum hub diameter			Gewicht ohne Buchse Weight without bushing (≈ kg)	Fr. Stück ohne Buchse each without bushing
						Material				
						GG	GGG	St		
1008 AM 1008 BM	St St	1008 1008	45 45	22 22	5 x 2,5	71 75	62 67	56 60	0,1 0,1	46,72 46,72
1210 AM 1210 BM	St St	1210 1210	60 60	25 25	6 x 3	86 92	79 86	73 83	0,2 0,2	70,24 73,44
1610 AM 1610 BM	St St	1610 1610	70 70	25 25	10 x 4	95 102	89 95	83 89	0,3 0,3	84,32 87,36
1615 AM 1615 BM	St St	1615 1615	70 70	38 38	10 x 4	95 102	89 95	83 89	0,4 0,4	92,16 95,36
2517 AM 2517 BM	St St	2517 2517	105 105	45 45	16 x 4	143 149	133 140	121 127	1,0 1,0	123,36 124,80
3030 AM 3030 BM	St St	3030 3030	130 130	76 76	20 x 5	178 187	165 175	156 159	2,5 2,5	212,64 216,16
3535 AM 3535 BM	St St	3535 3535	160 160	89 89	22 x 5	222 232	203 213	191 200	5,2 5,2	345,60 354,56
4040 AM 4040 BM	St St	4040 4040	185 185	102 102	24 x 5	273 283	248 257	229 238	8,0 8,0	423,68 434,24

St = Stahl Steel GG = Grauguss Cast iron GGG = Globularer Grauguss Spheroidal graphite cast iron AM = Ohne Keilnut Without keyway BM = Mit Keilnut With keyway

Taper-Buchse Taper bushing	1008	1210	1610	1615	2517	3030	3535	4040
Bohrung d ₂ (mm) von ... bis ... Bore d ₂ (mm) from ... to ...	10-25	11-32	14-42	14-42	16-60	35-75	35-90	40-100
Fr./Stück each	12,48	18,40	20,80	23,04	37,60	66,08	127,04	178,56

Bohrungsdurchmesser d₂ siehe Seite 3. Bore diameters d₂ see page 3. Weitere Abmessungen auf Anfrage. Further sizes on request. Fertigungstechnische Änderungen vorbehalten. We reserve the right to make technical changes.

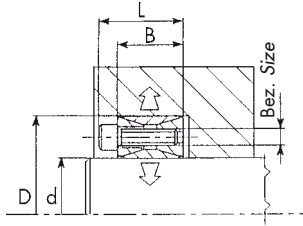

Type CE01

Bezeichnung Designation	Abmessung Dimension				Schrauben Screws			Bei Anzugsmoment M _s übertragbar With tightening torque M _s applied		Flächen- pressung Pressure		Gewicht Weight	Fr./Stück each
	d	D	B	L	Bezeichnung Designation	Anzahl No.	Anzugs- moment Tightening torque M _s	Drehmoment Torque	Axialkraft Axial force	Welle Shaft	Nabe Hub		
								M	F	P _w	P _N		
								(Nm)	(KN)	(N/mm ²)	(N/mm ²)		
(mm)	(mm)	(mm)	(mm)	Stück each	(Nm)	(Nm)	(KN)	(N/mm ²)	(N/mm ²)	(kg)			
CE01- 18	18	47	20	26	M 6 x 18	8	16	250	28	240	92	0,210	56,96
CE01- 19	19	47	20	26	M 6 x 18	8	16	260	28	225	92	0,210	56,96
CE01- 20	20	47	20	26	M 6 x 18	8	16	280	28	215	92	0,210	56,96
CE01- 22	22	47	20	26	M 6 x 18	8	16	310	28	195	92	0,200	56,96
CE01- 24	24	50	20	26	M 6 x 18	8	16	330	28	180	87	0,222	59,36
CE01- 25	25	50	20	26	M 6 x 18	8	16	350	28	175	87	0,220	59,36
CE01- 28	28	55	20	26	M 6 x 18	12	16	580	42	230	118	0,266	61,92
CE01- 30	30	55	20	26	M 6 x 18	12	16	630	42	215	118	0,254	61,92
CE01- 32	32	60	20	26	M 6 x 18	12	16	670	42	200	110	0,302	68,32
CE01- 35	35	60	20	26	M 6 x 18	12	16	730	42	185	110	0,282	68,32
CE01- 38	38	65	20	26	M 6 x 18	15	16	990	52	215	125	0,328	73,60
CE01- 40	40	65	20	26	M 6 x 18	15	16	1040	52	200	125	0,318	73,60
CE01- 42	42	75	24	32	M 8 x 22	12	38	1600	76	240	140	0,560	84,00
CE01- 45	45	75	24	32	M 8 x 22	12	38	1700	76	225	140	0,528	84,00
CE01- 48	48	80	24	32	M 8 x 22	12	38	1800	76	210	120	0,590	89,92
CE01- 50	50	80	24	32	M 8 x 22	12	38	1900	76	200	130	0,560	89,92
CE01- 55	55	85	24	32	M 8 x 22	15	38	2600	95	230	150	0,622	89,92
CE01- 60	60	90	24	32	M 8 x 22	15	38	2850	95	210	140	0,660	101,76
CE01- 65	65	95	24	32	M 8 x 22	15	38	3100	95	195	130	0,798	105,76
CE01- 70	70	110	28	38	M10 x 25	15	75	5350	150	240	160	1,238	149,28
CE01- 75	75	115	28	38	M10 x 25	15	75	5730	150	225	150	1,294	154,72
CE01- 80	80	120	28	38	M10 x 25	15	75	6100	150	210	140	1,364	157,76
CE01- 85	85	125	28	38	M10 x 25	15	75	6500	150	200	140	1,428	187,84
CE01- 90	90	130	28	38	M10 x 25	15	75	6900	150	185	130	1,482	191,36
CE01- 95	95	135	28	38	M10 x 25	18	75	8700	180	210	150	1,568	200,32
CE01-100	100	145	30	42	M12 x 30	15	130	11200	220	230	160	2,154	237,44
CE01-110	110	155	30	42	M12 x 30	15	130	12300	220	205	150	2,306	246,40
CE01-120	120	165	30	42	M12 x 30	16	130	14300	240	200	150	2,486	255,20
CE01-130	130	180	38	50	M12 x 35	20	130	19400	300	180	130	3,586	366,88
CE01-140	140	190	38	50	M12 x 35	22	130	23000	330	180	140	3,810	393,44
CE01-150	150	200	38	50	M12 x 35	24	130	26900	360	185	140	4,084	436,00
CE01-160	160	210	38	50	M12 x 35	26	130	31000	390	190	150	4,360	483,84
CE01-170	170	225	44	58	M14 x 40	22	200	36300	430	175	140	5,700	551,20
CE01-180	180	235	44	58	M14 x 40	24	200	42000	470	180	140	6,000	618,56
CE01-190	190	250	52	66	M14 x 45	28	200	51800	550	165	130	8,000	834,88
CE01-200	200	260	52	66	M14 x 45	30	200	58300	590	165	130	8,200	905,76
CE01-220*	220	285	56	72	M16 x 50	26	300	74100	680	160	130	11,000	1.137,92
CE01-240*	240	305	56	72	M16 x 50	30	300	93200	780	170	140	12,300	1.261,92
CE01-260*	260	325	56	72	M16 x 50	34	300	114500	890	180	150	13,000	1.770,72
CE01-280*	280	355	66	84	M18 x 60	32	410	141000	1000	160	130	19,000	2.238,56
CE01-300*	300	375	66	84	M18 x 60	36	410	170000	1140	165	140	20,200	2.575,36
CE01-320*	320	405	78	98	M20 x 70	36	590	235500	1500	170	140	30,600	} auf Anfrage on request
CE01-340*	340	425	78	98	M20 x 70	36	590	250000	1500	160	130	30,800	
CE01-360*	360	455	90	112	M22 x 80	36	790	329000	1800	160	130	43,200	
CE01-380*	380	475	90	112	M22 x 80	36	790	346400	1800	150	120	45,000	
CE01-400	400	495	90	112	M22 x 80	36	790	365000	1800	145	120	46,800	

* Keine Lagerware Non stock items

Fertigungstechnische Änderungen vorbehalten. We reserve the right to make technical changes.

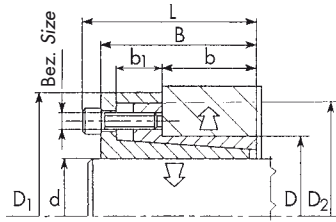

Type CE02

Bezeichnung Designation	Abmessung Dimension								Schrauben Screws			Bei Anzugsmoment M _s übertragbar With tightening torque M _s applied		Flächen- pression Pressure		Gewicht Weight (kg)	Fr./Stück each		
	d	D	D ₁	D ₂	b	b ₁	B	L	Bezeichnung Designation	Anzahl No. Stück each	Anzugs- moment Tighten- ing torque M _s (Nm)	Drehmoment Torque M (Nm)	Axialkraft Axial force F (K _N)	Welle Shaft P _w (N/ mm ²)	Nabe Hub P _N (N/ mm ²)				
																		Fr./Stück each	
																		Fr./Stück each	
CE02- 6*	6	14	25	23	9	9,5	21,5	24,5	M 3 x 10	4	2	14	4,8	103	95	0,080	77,60		
CE02- 8*	8	15	27	24	12	10,0	25,0	29,0	M 4 x 10	3	5	28	7,0	104	101	0,100	77,60		
CE02- 10*	10	16	29	26	14	8,5	26,0	30,0	M 4 x 10	4	5	46	9,0	110	108	0,120	77,60		
CE02- 12	12	18	32	28	14	8,5	26,0	30,0	M 4 x 10	4	5	55	9,0	88	96	0,140	77,60		
CE02- 14	14	23	38	33	14	8,5	26,0	30,0	M 4 x 10	4	5	64	9,0	75	75	0,150	77,60		
CE02- 15	15	24	45	40	16	12,5	36,0	42,0	M 6 x 16	4	15	150	19,0	102	132	0,209	77,60		
CE02- 16	16	24	45	40	16	12,5	36,0	42,0	M 6 x 16	4	15	150	19,0	96	132	0,218	77,60		
CE02- 18	18	26	47	43	18	13,0	38,0	44,0	M 6 x 18	4	17	200	23,0	102	129	0,226	77,60		
CE02- 19	19	27	49	44	18	13,0	38,0	44,0	M 6 x 18	4	17	210	23,0	97	125	0,248	77,60		
CE02- 20	20	28	49	44	18	13,0	38,0	44,0	M 6 x 18	4	17	220	23,0	92	120	0,248	80,00		
CE02- 22	22	32	54	49	25	13,0	45,0	51,0	M 6 x 18	4	17	250	23,0	69	76	0,325	82,40		
CE02- 24	24	34	56	51	25	13,0	45,0	51,0	M 6 x 18	4	17	270	23,0	63	71	0,344	82,40		
CE02- 25	25	34	56	51	25	13,0	45,0	51,0	M 6 x 18	4	17	280	23,0	61	71	0,332	88,16		
CE02- 28	28	39	61	56	25	13,0	45,0	51,0	M 6 x 18	6	17	500	34,0	81	93	0,410	88,16		
CE02- 30	30	41	62	57	25	13,0	45,0	51,0	M 6 x 18	6	17	520	34,0	76	89	0,414	88,16		
CE02- 32	32	43	65	59	30	13,0	50,0	56,0	M 6 x 18	8	17	730	46,0	84	94	0,478	105,44		
CE02- 35	35	47	69	64	30	13,0	50,0	56,0	M 6 x 18	8	17	800	46,0	77	86	0,546	105,44		
CE02- 38	38	50	72	67	30	13,0	50,0	56,0	M 6 x 18	8	17	900	46,0	71	81	0,580	114,08		
CE02- 40	40	53	75	70	30	13,0	50,0	56,0	M 6 x 18	8	17	900	46,0	67	76	0,626	114,08		
CE02- 42	42	55	78	73	40	17,0	65,0	73,0	M 8 x 22	8	41	1800	84,0	89	101	0,880	132,80		
CE02- 45	45	59	85	79	40	17,0	65,0	73,0	M 8 x 22	8	41	1900	84,0	84	94	1,028	141,60		
CE02- 48	48	62	87	82	45	17,0	70,0	78,0	M 8 x 22	8	41	2000	84,0	72	79	0,980	154,56		
CE02- 50	50	65	92	85	45	17,0	70,0	78,0	M 8 x 22	10	41	2600	105,0	87	95	1,270	163,52		
CE02- 55	55	71	98	92	50	17,0	75,0	83,0	M 8 x 22	10	41	2900	105,0	73	78	1,480	198,56		
CE02- 60	60	77	104	98	50	17,0	75,0	83,0	M 8 x 22	10	41	3100	105,0	67	72	1,658	221,60		
CE02- 65	65	84	111	105	50	17,0	75,0	83,0	M 8 x 22	10	41	3400	105,0	62	66	1,922	253,44		
CE02- 70	70	90	119	114	60	20,0	91,0	101,0	M10 x 25	10	83	5800	170,0	91	82	2,936	322,56		
CE02- 75	75	95	126	120	60	20,0	91,0	101,0	M10 x 25	10	83	6200	170,0	70	77	2,290	384,64		
CE02- 80	80	100	131	125	65	20,0	96,0	106,0	M10 x 25	12	83	7800	200,0	74	81	3,342	416,48		
CE02- 85	85	106	137	131	65	20,0	96,0	106,0	M10 x 25	12	83	8500	200,0	70	77	3,622	420,00		
CE02- 90	90	112	143	137	65	20,0	96,0	106,0	M10 x 25	15	83	11200	250,0	83	91	3,956	452,00		
CE02- 95*	95	120	153	146	65	20,0	96,0	106,0	M10 x 25	15	83	11800	250,0	78	85	4,460	499,84		
CE02-100*	100	125	162	155	65	24,0	102,0	114,0	M12 x 30	12	145	14600	300,0	82	95	6,000	499,84		

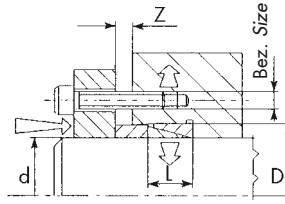

Type CE03

Bezeichnung Designation	Abmessung Dimension							Bei Anzugsmoment M_s übertragbar With tightening torque M_s applied		Flächen- pression Pressure		Ges. Axialkraft der Spann- schrauben Total axial force on the tension screws	Gewicht Weight	Fr./Stück each
	d	D	L	Z				Drehmoment Torque	Axialkraft Axial force	Welle Shaft	Nabe Hub			
				1	2	3	4							
				(mm)	(mm)	(mm)	(mm)					(mm)	(mm)	
CE03- 6*	6	9	4,5	3	3	3	4	2	0,8	96	65	4	0,001	12,96
CE03- 8*	8	11	4,5	3	3	3	4	5	1,0	108	80	6	0,001	12,96
CE03- 10*	10	13	4,5	3	3	3	4	10	2,0	112	100	16	0,002	12,96
CE03- 12*	12	15	4,5	3	3	3	4	11	2,0	111	90	16	0,002	12,96
CE03- 14	14	18	6,3	3	4	4	5	22	3,0	112	90	26	0,004	12,96
CE03- 15	15	19	6,3	3	4	4	5	25	3,0	112	90	27	0,004	12,96
CE03- 16	16	20	6,3	3	4	4	5	26	3,0	112	90	27	0,005	12,96
CE03- 17	17	21	6,3	3	4	4	5	30	3,0	112	90	27	0,006	12,96
CE03- 18	18	22	6,3	3	4	4	5	33	3,0	112	90	33	0,006	12,96
CE03- 19	19	24	6,3	3	4	4	5	40	4,0	112	90	33	0,006	12,96
CE03- 20	20	25	6,3	3	4	4	5	44	4,0	112	90	33	0,008	12,96
CE03- 22	22	26	6,3	3	4	4	5	50	4,0	100	90	34	0,010	12,96
CE03- 24	24	28	6,3	3	4	4	5	68	6,0	114	100	34	0,006	12,96
CE03- 25	25	30	6,3	3	4	4	5	75	6,0	120	100	37	0,010	12,96
CE03- 28	28	32	6,3	3	4	4	5	90	6,0	111	100	40	0,008	13,44
CE03- 30	30	35	6,3	3	4	4	5	100	7,0	111	100	40	0,012	13,44
CE03- 32	32	36	6,3	3	4	4	5	120	7,0	111	100	40	0,010	13,44
CE03- 35	35	40	7,0	3	4	4	5	160	9,0	111	100	50	0,015	13,44
CE03- 38	38	44	7,0	4	5	5	6	190	10,0	111	100	60	0,020	13,44
CE03- 40	40	45	8,0	4	5	5	6	230	11,0	111	100	70	0,020	13,44
CE03- 42	42	48	8,0	4	5	5	6	260	12,0	111	100	70	0,025	20,32
CE03- 45	45	52	10,0	4	5	5	6	390	17,0	111	100	110	0,039	20,32
CE03- 48	48	55	10,0	4	5	5	6	430	18,0	111	100	110	0,042	20,32
CE03- 50	50	57	10,0	4	5	5	6	470	19,0	111	100	110	0,044	20,32
CE03- 55	55	62	10,0	4	5	5	6	580	21,0	111	100	120	0,048	24,32
CE03- 60	60	68	12,0	4	5	6	7	840	28,0	111	100	160	0,072	24,32
CE03- 65	65	73	12,0	4	5	6	7	1000	30,0	111	100	160	0,078	27,84
CE03- 70	70	79	14,0	4	5	6	7	1300	38,0	111	100	200	0,112	34,08
CE03- 75	75	84	14,0	4	5	6	7	1500	41,0	111	100	220	0,120	40,00
CE03- 80	80	91	17,0	5	6	7	8	2100	54,0	111	100	300	0,190	45,92
CE03- 85*	85	96	17,0	5	6	7	8	2300	56,0	111	100	310	0,200	61,44
CE03- 90	90	101	17,0	5	6	7	8	2700	61,0	111	100	320	0,212	61,44
CE03- 95*	95	106	17,0	5	6	7	8	3500	73,0	111	100	380	0,230	73,60
CE03-100	100	114	21,0	5	6	8	9	4200	84,0	111	100	440	0,376	73,60
CE03-110*	110	124	21,0	5	6	8	9	4300	86,0	111	90	450	0,410	79,04
CE03-120*	120	134	21,0	5	6	8	9	5100	88,0	111	90	460	0,450	87,04
CE03-130*	130	148	28,0	6	7	9	11	8100	125,0	111	90	650	0,828	117,28
CE03-140*	140	158	28,0	6	7	9	11	9400	135,0	111	90	690	0,898	136,16
CE03-150*	150	168	28,0	6	7	9	11	11000	145,0	111	90	720	0,973	144,32

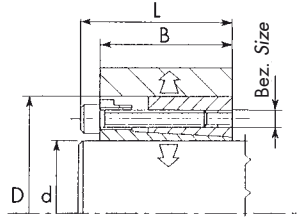

Type CE04

Bezeichnung Designation	Abmessung Dimension				Schrauben Screws			Bei Anzugsmoment M_s übertragbar With tightening torque M_s applied		Flächen- pressung Pressure		Gewicht Weight	Fr./Stück each
								Drehmoment Torque	Axialkraft Axial force	Welle Shaft	Nabe Hub		
	d	D	B	L	Bezeichnung Designation	Anzahl No.	Anzugs- moment Tightening torque M_s	M	F	P_w	P_N		
	(mm)	(mm)	(mm)	(mm)		Stück each	(Nm)	(Nm)	(kN)	(N/ mm ²)	(N/ mm ²)		
CE04- 20	20	47	42	48	M 6 x 25	6	17	530	52	190	110	0,384	61,60
CE04- 22	22	47	42	48	M 6 x 25	6	17	580	52	170	110	0,366	61,60
CE04- 24	24	50	42	48	M 6 x 25	6	17	630	52	160	100	0,410	68,00
CE04- 25	25	50	42	48	M 6 x 25	6	17	660	52	150	100	0,402	68,00
CE04- 28	28	55	42	48	M 6 x 25	6	17	740	52	130	100	0,482	68,00
CE04- 30	30	55	42	48	M 6 x 25	6	17	790	52	130	100	0,458	68,00
CE04- 32	32	60	42	48	M 6 x 25	8	17	1180	70	160	120	0,520	72,16
CE04- 35	35	60	42	48	M 6 x 25	8	17	1230	70	140	120	0,510	72,16
CE04- 38	38	65	42	48	M 6 x 25	8	17	1300	70	130	110	0,600	74,24
CE04- 40	40	65	42	48	M 6 x 25	8	17	1400	70	125	110	0,568	74,24
CE04- 42	42	75	50	58	M 8 x 30	6	41	2000	100	130	120	1,020	91,68
CE04- 45	45	75	50	58	M 8 x 30	6	41	2200	100	125	120	0,934	91,68
CE04- 48	48	80	50	58	M 8 x 30	8	41	3200	130	155	150	1,050	95,36
CE04- 50	50	80	50	58	M 8 x 30	8	41	3300	130	150	150	1,008	95,36
CE04- 55	55	85	50	58	M 8 x 30	8	41	3600	130	135	140	1,124	106,08
CE04- 60	60	90	50	58	M 8 x 30	8	41	3900	130	125	130	1,210	112,80
CE04- 65	65	95	50	58	M 8 x 30	8	41	4200	130	115	120	1,234	196,80
CE04- 70	70	110	60	70	M10 x 30	8	83	7500	210	150	130	2,306	212,64
CE04- 75*	75	115	60	70	M10 x 30	8	83	8000	210	140	130	2,466	219,84
CE04- 80	80	120	60	70	M10 x 30	8	83	8500	210	130	120	2,588	221,60
CE04- 85*	85	125	60	70	M10 x 30	10	83	11400	270	155	150	2,700	248,16
CE04- 90	90	130	60	70	M10 x 30	10	83	12000	270	145	140	2,832	255,20
CE04-100	100	145	68	80	M12 x 35	8	145	15000	300	130	120	3,936	327,84
CE04-110*	110	155	68	80	M12 x 35	8	145	16500	300	120	110	4,300	487,36
CE04-120*	120	165	68	80	M12 x 35	10	145	22500	370	135	130	4,600	538,88
CE04-130*	130	180	68	80	M12 x 35	12	145	29300	450	150	140	5,500	606,24
CE04-140*	140	190	76	90	M14 x 40	10	210	32200	460	130	125	6,700	611,52
CE04-150*	150	200	76	90	M14 x 40	12	210	41400	550	145	140	7,000	616,80
CE04-160*	160	210	76	90	M14 x 40	12	210	44100	550	135	130	7,500	634,56
CE04-170*	170	225	76	90	M14 x 40	14	210	54700	640	150	150	8,700	771,04
CE04-180*	180	235	76	90	M14 x 40	14	210	57900	640	140	140	9,200	809,92

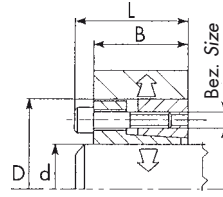

Type CE05

Bezeichnung Designation	Abmessung Dimension				Schrauben Screws			Bei Anzugsmoment M _s übertragbar With tightening torque M _s applied		Flächen- pressung Pressure		Gewicht Weight	Fr./Stück each
	d	D	B	L	Bezeichnung Designation	Anzahl No.	Anzugs- moment Tightening torque M _s	Drehmoment Torque	Axialkraft Axial force	Welle Shaft	Nabe Hub		
								M	F	P _W	P _N		
	(mm)	(mm)	(mm)	(mm)		Stück each	(Nm)	(Nm)	(KN)	(N/ mm ²)	(N/ mm ²)		
CE05- 20	20	47	28	34	M 6 x 20	6	14	410	41	218	137	0,260	53,12
CE05- 22	22	47	28	34	M 6 x 20	6	14	450	41	198	137	0,250	53,12
CE05- 24*	24	50	28	34	M 6 x 20	6	14	490	41	182	128	0,276	58,24
CE05- 25	25	50	28	34	M 6 x 20	6	14	510	41	175	128	0,268	58,24
CE05- 28*	28	55	28	34	M 6 x 20	6	14	570	41	156	117	0,322	58,24
CE05- 30	30	55	28	34	M 6 x 20	6	14	610	41	145	117	0,304	60,80
CE05- 32*	32	60	28	34	M 6 x 20	8	14	880	54	182	143	0,370	67,52
CE05- 35	35	60	28	34	M 6 x 20	8	14	960	54	166	143	0,344	67,52
CE05- 38*	38	65	28	34	M 6 x 20	8	14	1040	54	153	132	0,408	71,20
CE05- 40	40	65	28	34	M 6 x 20	8	14	1090	54	145	132	0,378	71,20
CE05- 42*	42	75	33	41	M 8 x 25	8	35	2200	105	201	186	0,630	82,56
CE05- 45	45	75	33	41	M 8 x 25	8	35	2360	105	207	186	0,630	82,56
CE05- 48*	48	80	33	41	M 8 x 25	8	35	2520	105	194	174	0,680	87,84
CE05- 50	50	80	33	41	M 8 x 25	8	35	2620	105	186	174	0,686	87,84
CE05- 55*	55	85	33	41	M 8 x 25	8	35	2890	105	169	164	0,720	102,56
CE05- 60	60	90	33	41	M 8 x 25	8	35	3150	105	155	155	0,794	102,56
CE05- 65*	65	95	33	41	M 8 x 25	8	35	3410	105	143	174	0,842	128,64
CE05- 70*	70	110	40	50	M10 x 30	8	70	5990	170	180	172	1,534	198,56
CE05- 75*	75	115	40	50	M10 x 30	8	70	6420	170	168	165	1,634	216,16
CE05- 80*	80	120	40	50	M10 x 30	8	70	6850	170	158	158	1,722	216,16
CE05- 85*	95	125	40	50	M10 x 30	10	70	9090	210	186	189	1,834	242,88
CE05- 90*	90	130	40	50	M10 x 30	10	70	9630	210	175	182	1,900	249,92
CE05-100*	100	145	44	56	M12 x 30	8	115	11900	240	158	168	2,618	320,80
CE05-110*	110	155	44	56	M12 x 30	8	115	13090	240	144	157	2,788	338,56
CE05-120*	120	165	44	56	M12 x 30	9	115	16060	270	148	166	3,600	342,08
CE05-130*	130	180	52	64	M12 x 30	12	115	23200	360	152	155	4,410	467,84
CE05-140*	140	190	54	68	M14 x 40	9	185	25500	360	138	150	4,920	487,36
CE05-150*	150	200	54	68	M14 x 40	10	185	30300	400	143	158	5,200	572,48
CE05-160*	160	210	54	68	M14 x 40	12	185	38800	490	161	181	5,600	595,52
CE05-180*	180	235	64	78	M14 x 40	12	185	43700	490	119	125	8,500	744,48
CE05-200*	200	260	64	78	M14 x 40	15	185	60700	610	134	141	9,600	969,44

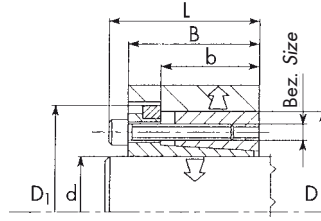

Type CE06

Bezeichnung Designation	Abmessung Dimension						Schrauben Screws			Bei Anzugsmoment M _s übertragbar With tightening torque M _s applied		Flächen- pression Pressure		Gewicht Weight (kg)	Fr./Stück each
	d	D	D ₁	b	B	L	Bezeichnung Designation	Anzahl No. Stück each	Anzugs- moment Tighten- ing torque M _s (Nm)	Drehmoment Torque M (Nm)	Axialkraft Axial force F (kN)	Welle	Nabe		
												Shaft	Hub		
												P _w	P _N		
(mm)	(mm)	(mm)	(mm)	(mm)	(mm)						(N/ mm ²)	(N/ mm ²)			
CE06- 20	20	47	53	31,0	42	48	M 6 x 25	6	17	320	33	116	70	0,416	68,80
CE06- 22	22	47	53	31,0	42	48	M 6 x 25	6	17	360	33	105	70	0,398	68,80
CE06- 24	24	50	56	31,0	42	48	M 6 x 25	6	17	390	33	97	70	0,442	75,36
CE06- 25	25	50	56	31,0	42	48	M 6 x 25	6	17	400	33	93	70	0,434	75,36
CE06- 28	28	55	61	31,0	42	48	M 6 x 25	6	17	450	33	83	60	0,516	75,36
CE06- 30	30	55	61	31,0	42	48	M 6 x 25	6	17	490	33	77	60	0,492	75,36
CE06- 32	32	60	66	31,0	42	48	M 6 x 25	8	17	690	43	97	70	0,560	81,76
CE06- 35	35	60	66	31,0	42	48	M 6 x 25	8	17	750	43	88	70	0,548	81,76
CE06- 38	38	65	71	31,0	42	48	M 6 x 25	8	17	820	43	81	70	0,650	84,00
CE06- 40	40	65	71	31,0	42	48	M 6 x 25	8	17	860	43	77	70	0,608	84,00
CE06- 42	42	75	81	36,0	50	58	M 8 x 30	6	41	1250	60	82	70	1,090	101,44
CE06- 45	45	75	81	36,0	50	58	M 8 x 30	6	41	1340	60	77	70	1,004	101,44
CE06- 48	48	80	86	36,0	50	58	M 8 x 30	8	41	1910	80	96	90	1,100	105,28
CE06- 50	50	80	86	36,0	50	58	M 8 x 30	8	41	1990	80	92	90	1,074	105,28
CE06- 55	55	85	91	36,0	50	58	M 8 x 30	8	41	2200	80	84	90	1,204	118,24
CE06- 60	60	90	96	36,0	50	58	M 8 x 30	8	41	2400	80	77	80	1,292	130,56
CE06- 65	65	95	101	36,0	50	58	M 8 x 30	8	41	2600	80	71	70	1,308	214,40
CE06- 70	70	110	119	46,0	60	70	M10 x 30	8	83	4600	130	92	80	2,440	230,40
CE06- 75*	75	115	124	46,0	60	70	M10 x 30	8	83	4930	130	86	80	2,596	239,20
CE06- 80	80	120	129	46,0	60	70	M10 x 30	8	83	5200	130	81	70	2,730	242,88
CE06- 85*	85	125	134	46,0	60	70	M10 x 30	10	83	7000	165	95	90	2,800	265,92
CE06- 90	90	130	139	46,0	60	70	M10 x 30	10	83	7400	165	90	80	2,986	276,48
CE06-100	100	145	155	52,0	68	80	M12 x 35	8	145	9700	190	84	80	4,136	358,08
CE06-110*	110	155	165	52,0	68	80	M12 x 35	8	145	10680	190	77	70	4,500	524,64
CE06-120*	120	165	175	52,0	68	80	M12 x 35	10	145	14500	240	88	90	4,800	593,76
CE06-130*	130	180	188	52,0	68	80	M12 x 35	12	145	18900	290	97	100	5,800	666,40
CE06-140*	140	190	199	58,5	76	90	M14 x 40	10	230	22800	325	91	90	7,000	669,92
CE06-150*	150	200	209	58,5	76	90	M14 x 40	12	230	29300	390	102	100	7,300	685,92
CE06-160*	160	210	219	58,5	76	90	M14 x 40	12	230	31300	390	95	100	7,800	721,44
CE06-170*	170	225	234	58,5	76	90	M14 x 40	14	230	38800	460	105	110	9,600	859,68
CE06-180*	180	235	244	58,5	76	90	M14 x 40	14	230	41000	460	99	100	9,000	870,24

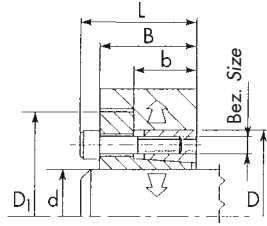

Type CE07

Bezeichnung Designation	Abmessung Dimension						Schrauben Screws			Bei Anzugsmoment M_s übertragbar With tightening torque M_s applied		Flächen- pressung Pressure		Gewicht Weight	Fr./Stück each
										Drehmoment Torque	Axialkraft Axial force	Welle Shaft	Nabe Hub		
	d	D	D ₁	b	B	L	Bezeichnung Designation	Anzahl No.	Anzugs- moment Tighten- ing torque M_s	M	F	P _w	P _N		
	(mm)	(mm)	(mm)	(mm)	(mm)	(mm)		Stück each	(Nm)	(Nm)	(K _N)	(N/ mm ²)	(N/ mm ²)		
CE07- 20	20	47	56	22	28	34	M 6 x 20	6	17	320	32	171	100	0,280	53,12
CE07- 22	22	47	56	22	28	34	M 6 x 20	6	17	350	32	156	100	0,270	53,12
CE07- 24	24	50	59	22	28	34	M 6 x 20	6	17	390	32	143	100	0,310	58,24
CE07- 25	25	50	59	22	28	34	M 6 x 20	6	17	400	32	137	100	0,304	58,24
CE07- 28	28	55	64	22	28	34	M 6 x 20	6	17	450	32	122	90	0,362	58,24
CE07- 30	30	55	64	22	28	34	M 6 x 20	6	17	490	32	114	90	0,346	60,80
CE07- 32	32	60	69	22	28	34	M 6 x 20	8	17	700	43	143	110	0,420	67,52
CE07- 35	35	60	69	22	28	34	M 6 x 20	8	17	760	43	131	110	0,390	67,52
CE07- 38	38	65	74	22	28	34	M 6 x 20	8	17	820	43	120	100	0,454	71,20
CE07- 40	40	65	74	22	28	34	M 6 x 20	8	17	870	43	114	100	0,446	71,20
CE07- 42	42	75	84	25	33	41	M 8 x 25	6	41	1700	80	168	140	0,440	82,56
CE07- 45	45	75	84	25	33	41	M 8 x 25	6	41	1800	80	157	140	0,696	82,56
CE07- 48	48	80	89	25	33	41	M 8 x 25	8	41	1900	80	147	130	0,800	87,84
CE07- 50	50	80	89	25	33	41	M 8 x 25	8	41	2000	80	141	130	0,756	87,84
CE07- 55	55	85	91	25	33	41	M 8 x 25	8	41	2200	80	128	120	0,850	102,56
CE07- 60	60	90	99	25	33	41	M 8 x 25	8	41	2400	80	117	120	0,900	102,56
CE07- 65	65	95	104	25	33	41	M 8 x 25	8	41	2600	80	108	110	0,934	128,64
CE07- 70	70	110	119	30	40	50	M10 x 30	8	83	4600	130	138	130	1,670	198,56
CE07- 75	75	115	124	30	40	50	M10 x 30	8	83	5000	130	129	130	1,760	216,16
CE07- 80	80	120	129	30	40	50	M10 x 30	8	83	5300	130	121	120	1,868	216,16
CE07- 85	85	125	134	30	40	50	M10 x 30	10	83	7000	160	142	150	1,966	242,88
CE07- 90	90	130	139	30	40	50	M10 x 30	10	83	7400	160	135	140	2,046	249,92
CE07-100	100	145	154	32	44	56	M12 x 30	8	145	9700	200	129	140	2,830	320,80
CE07-110	110	155	164	32	44	56	M12 x 30	8	145	10700	200	117	130	3,100	338,56
CE07-120	120	165	174	32	44	56	M12 x 30	9	145	13100	220	121	140	3,284	342,08
CE07-130	130	180	189	40	52	64	M12 x 30	12	145	19000	290	124	130	4,600	467,84
CE07-140*	140	190	199	40	54	68	M14 x 40	9	230	20500	300	111	120	4,980	487,36
CE07-150*	150	200	209	40	54	68	M14 x 40	10	230	24500	330	115	130	5,200	572,48
CE07-160*	160	210	219	40	54	68	M14 x 40	12	230	31300	390	130	150	5,600	595,52
CE07-180*	180	235	244	50	64	78	M14 x 40	12	230	35000	390	96	100	8,500	744,48
CE07-200*	200	260	269	50	64	78	M14 x 40	15	230	49000	500	108	110	9,600	969,44

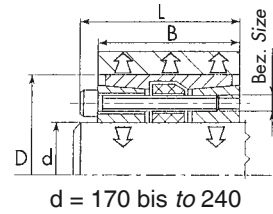
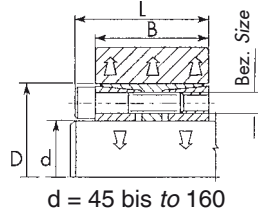
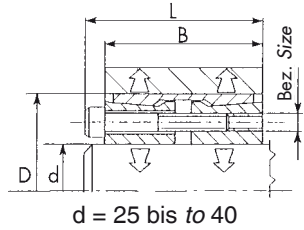

Type CE08

Bezeichnung Designation	Abmessung Dimension				Schrauben Screws			Bei Anzugsmoment M _s übertragbar With tightening torque M _s applied		Flächen- pression Pressure		Gewicht Weight	Fr./Stück each
								Drehmoment Torque	Axialkraft Axial force	Welle Shaft	Nabe Hub		
	d	D	B	L	Bezeichnung Designation	Anzahl No.	Anzugs- moment Tightening torque M _s	M	F	P _w	P _N		
(mm)	(mm)	(mm)	(mm)		Stück each	(Nm)	(Nm)	(kN)	(N/ mm ²)	(N/ mm ²)	(kg)		
CE08- 25*	25	50	45	51	M 6 x 35	6	17	700	55	157	80	0,415	141,28
CE08- 30*	30	55	45	51	M 6 x 35	8	17	1200	70	175	90	0,464	146,88
CE08- 35*	35	60	45	51	M 6 x 35	8	17	1400	70	150	90	0,526	163,04
CE08- 40*	40	65	45	51	M 6 x 35	10	17	2000	90	164	100	0,550	196,80
CE08- 45	45	75	45	53	M 8 x 35	8	41	3200	140	216	130	0,768	228,64
CE08- 50	50	80	64	72	M 8 x 55	8	41	3600	140	165	80	1,326	260,48
CE08- 55*	55	85	64	72	M 8 x 55	8	41	4000	140	150	80	1,430	287,20
CE08- 60	60	90	64	72	M 8 x 55	10	41	5400	170	171	90	1,524	292,48
CE08- 65*	65	95	64	72	M 8 x 55	10	41	5800	170	158	90	2,000	359,84
CE08- 70	70	110	78	88	M10 x 60	10	83	10300	280	199	100	2,932	421,76
CE08- 75*	75	115	78	88	M10 x 60	10	83	11000	280	186	100	3,100	469,76
CE08- 80	80	120	78	88	M10 x 60	12	83	14000	340	209	110	3,300	485,60
CE08- 85*	85	125	78	88	M10 x 60	12	83	15000	340	197	110	3,400	515,84
CE08- 90	90	130	78	88	M10 x 60	12	83	16000	340	186	100	3,600	522,88
CE08- 95*	95	135	78	88	M10 x 60	12	83	17000	340	176	100	4,000	639,84
CE08-100	100	145	100	112	M12 x 80	12	145	26000	500	198	100	6,000	680,64
CE08-110*	110	155	100	112	M12 x 80	12	145	29000	500	180	100	6,000	767,52
CE08-120*	120	165	100	112	M12 x 80	14	145	36400	600	192	110	6,000	825,92
CE08-130*	130	180	116	130	M14 x 90	12	230	45400	700	174	100	10,100	1.139,68
CE08-140*	140	190	116	130	M14 x 90	14	230	57000	800	189	110	10,500	1.400,16
CE08-150*	150	200	116	130	M14 x 90	16	230	70000	900	201	120	11,000	1.488,80
CE08-160*	160	210	116	130	M14 x 90	16	230	75000	900	189	110	12,000	1.573,92
CE08-170*	170	225	146	162	M16 x 110	14	355	95000	1100	168	100	17,000	1.807,84
CE08-180*	180	235	146	162	M16 x 110	15	355	115000	1200	182	110	18,400	1.923,04
CE08-190*	190	250	146	162	M16 x 110	16	355	121500	1200	172	100	21,400	2.243,84
CE08-200*	200	260	146	162	M16 x 110	16	355	128000	1200	163	100	21,800	2.391,04

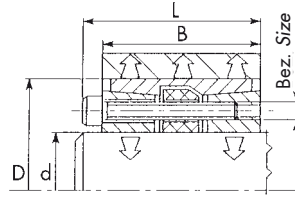

Type CE09

Bezeichnung Designation	Abmessung Dimension				Schrauben Screws			Bei Anzugsmoment M_s übertragbar With tightening torque M_s applied		Flächen- pressionung Pressure		Gewicht Weight	Fr./Stück each
	d	D	B	L	Bezeichnung Designation	Anzahl No.	Anzugs- moment Tightening torque M_s	Drehmoment Torque	Axialkraft Axial force	Welle Shaft	Nabe Hub		
								M	F	P_W	P_N		
								(Nm)	(kN)	(N/ mm ²)	(N/ mm ²)		
(mm)	(mm)	(mm)	(mm)		Stück each	(Nm)				(kg)			
CE09- 45*	45	75	64	72	M 8 x 55	8	41	3200	120	210	125	1,000	342,08
CE09- 50*	50	80	78	86	M 8 x 65	8	41	3550	120	140	65	1,500	372,16
CE09- 60	60	90	78	86	M 8 x 65	10	41	5330	150	146	75	2,000	420,00
CE09- 70	70	110	102	112	M10 x 90	10	83	10260	250	147	75	4,000	632,80
CE09- 80*	80	120	102	112	M10 x 90	12	83	14000	300	154	85	5,000	712,48
CE09- 90*	90	130	102	112	M10 x 90	12	83	15800	300	137	75	6,000	740,80
CE09-100*	100	145	122	134	M12 x 110	12	145	26000	450	149	85	7,000	960,64

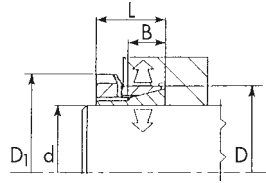

Type CE10

Bezeichnung Designation	Abmessung Dimension					Schrauben Screws			Bei Anzugsmoment M_s übertragbar With tightening torque M_s applied		Flächen- pression Pressure		Gewicht Weight	Fr./Stück each
									Drehmoment Torque	Axialkraft Axial force	Welle Shaft	Nabe Hub		
	d	D	D ₁	B	L	Bezeichnung Designation	Anzahl No.	Anzugs- moment tightening torque M_s	M	F	P _W	P _N		
	(mm)	(mm)	(mm)	(mm)	(mm)		Stück each	(Nm)	(Nm)	(K _N)	(N/ mm ²)	(N/ mm ²)		
CE10-14	14	25	32	6,5	16,5	M20 x 1,5	1	65	37	6	171	73	0,052	29,76
CE10-15	15	25	32	6,5	16,5	M20 x 1,5	1	65	40	6	159	73	0,050	29,76
CE10-16	16	25	32	6,5	16,5	M20 x 1,5	1	65	42	6	149	73	0,048	32,96
CE10-18	18	30	38	7,0	17,0	M25 x 1,5	1	85	65	8	168	80	0,080	32,96
CE10-19	19	30	38	7,0	17,0	M25 x 1,5	1	95	60	7	136	70	0,078	35,84
CE10-20	20	30	38	7,0	17,0	M25 x 1,5	1	110	70	8	149	80	0,074	35,84
CE10-24	24	35	45	7,0	17,0	M30 x 1,5	1	155	100	10	147	80	0,100	37,60
CE10-25	25	35	45	7,0	17,0	M30 x 1,5	1	160	110	10	146	90	0,092	37,60
CE10-28	28	40	52	8,0	20,0	M35 x 1,5	1	200	140	11	126	70	0,140	40,96
CE10-30	30	40	52	8,0	20,0	M35 x 1,5	1	240	170	14	138	80	0,130	44,80
CE10-32	32	45	58	9,0	22,0	M40 x 1,5	1	320	210	15	135	80	0,170	45,44
CE10-35	35	45	58	9,0	22,0	M40 x 1,5	1	320	230	15	123	80	0,168	45,44
CE10-40	40	50	64	9,0	23,0	M45 x 1,5	1	440	330	19	132	90	0,216	45,44
CE10-45	45	55	70	10,0	25,5	M50 x 1,5	1	550	440	23	127	90	0,266	48,64
CE10-50*	50	60	75	10,0	25,5	M55 x 1,5	1	660	530	25	125	90	0,278	60,48
CE10-60*	60	70	85	12,0	29,5	M65 x 1,5	1	900	830	32	112	80	0,390	60,48

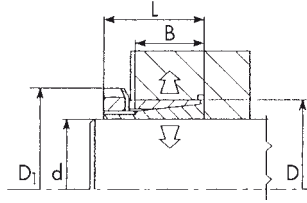

Type CE11

Bezeichnung Designation	Abmessung Dimension					Schrauben Screws			Bei Anzugsmoment M_s übertragbar With tightening torque M_s applied		Flächen- pression Pressure		Gewicht Weight	Fr./Stück each
									Drehmoment Torque	Axialkraft Axial force	Welle Shaft	Nabe Hub		
	d	D	D ₁	B	L	Bezeichnung Designation	Anzahl No.	Anzugs- moment Tightening torque M_s	M	F	P _W	P _N		
	(mm)	(mm)	(mm)	(mm)	(mm)		Stück each	(Nm)	(Nm)	(kN)	(N/ mm ²)	(N/ mm ²)		
CE11-14	14	25	32	17	29	M20 x 1,5	1	90	90	15	145	80	0,080	45,12
CE11-15	15	25	32	17	29	M20 x 1,5	1	90	100	15	136	80	0,074	45,12
CE11-16	16	25	32	17	29	M20 x 1,5	1	70	80	12	99	60	0,072	45,12
CE11-18	18	30	38	18	31	M25 x 1,5	1	190	200	25	179	110	0,120	47,68
CE11-19	19	30	38	18	31	M25 x 1,5	1	150	170	20	134	90	0,114	47,68
CE11-20	20	30	38	18	31	M25 x 1,5	1	110	130	15	93	60	0,104	47,68
CE11-24	24	35	45	22	35	M30 x 1,5	1	230	270	26	112	80	0,162	51,84
CE11-25	25	35	45	22	35	M30 x 1,5	1	170	200	19	80	60	0,150	51,84
CE11-28	28	40	52	22	35	M35 x 1,5	1	390	460	38	141	110	0,214	51,84
CE11-30	30	40	52	22	35	M35 x 1,5	1	240	300	24	63	70	0,192	51,84
CE11-32	32	45	58	27	42	M40 x 1,5	1	320	420	31	80	70	0,280	60,48
CE11-35	35	45	58	28	42	M40 x 1,5	1	320	460	31	70	60	0,270	60,48
CE11-40	40	50	64	28	44	M45 x 1,5	1	440	640	37	75	70	0,330	60,48
CE11-45	45	55	70	28	45	M50 x 1,5	1	550	760	40	71	60	0,386	74,40
CE11-50	50	60	75	28	46	M50 x 1,5	1	660	930	44	70	60	0,408	82,24
CE11-60	60	70	85	28	52	M65 x 1,5	1	1050	1500	59	79	70	0,550	98,56

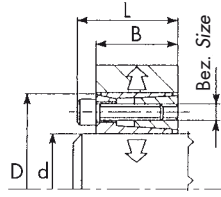

Type CE12

Bezeichnung Designation	Abmessung Dimension				Schrauben Screws			Bei Anzugsmoment M_s übertragbar With tightening torque M_s applied		Flächen- pression Pressure		Gewicht Weight	Fr./Stück each
								Drehmoment Torque	Axialkraft Axial force	Welle Shaft	Nabe Hub		
	d	D	B	L	Bezeichnung Designation	Anzahl No.	Anzugs- moment Tightening torque M_s	M	F	P_w	P_N		
	(mm)	(mm)	(mm)	(mm)		Stück each	(Nm)	(Nm)	(kN)	(N/ mm ²)	(N/ mm ²)		
CE12-16*	16	32	17,0	21,0	M4 x 14	4	5	80	13	134	68	0,070	66,88
CE12-18*	18	40	18,0	24,0	M6 x 15	4	17	180	24	119	100	0,122	76,64
CE12-19*	19	41	18,0	24,0	M6 x 15	4	17	190	24	215	100	0,126	76,64
CE12-20*	20	42	18,0	24,0	M6 x 15	4	17	200	24	204	100	0,130	76,64
CE12-22*	22	44	18,0	24,0	M6 x 15	4	17	220	24	186	90	0,138	76,64
CE12-24*	24	46	18,0	24,0	M6 x 15	6	17	360	36	170	130	0,150	82,24
CE12-25*	25	47	18,0	24,0	M6 x 15	6	17	380	36	245	130	0,160	82,24
CE12-28*	28	50	18,0	24,0	M6 x 15	6	17	420	36	219	120	0,165	86,08
CE12-30*	30	52	18,0	24,0	M6 x 15	6	17	450	36	204	120	0,174	86,08
CE12-32*	32	54	18,0	24,0	M6 x 15	6	17	480	36	191	110	0,184	95,52
CE12-35*	35	57	21,5	27,5	M6 x 15	6	17	520	36	139	90	0,242	95,52
CE12-40*	40	62	21,5	27,5	M6 x 15	8	17	600	36	122	80	0,272	102,24
CE12-45*	45	73	28,0	36,0	M8 x 22	8	41	1700	90	84	130	0,514	121,60
CE12-50*	50	78	28,0	36,0	M8 x 22	8	41	1840	90	187	120	0,570	121,60
CE12-60*	60	88	28,0	36,0	M8 x 22	8	41	2200	90	156	100	0,644	200,32

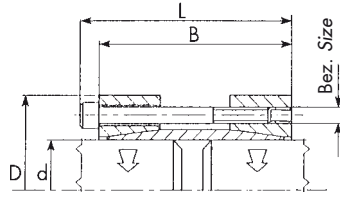

Type CE13

Bezeichnung Designation	Abmessung Dimension				Schrauben Screws			Bei Anzugsmoment M_s übertragbar With tightening torque M_s applied		Flächen- pression Pressure		Gewicht Weight	Fr./Stück each
								Drehmoment Torque	Axialkraft Axial force	Welle Shaft	Nabe Hub		
	d	D	B	L	Bezeichnung Designation	Anzahl No.	Anzugs- moment Tightening torque M_s	M	F	P_W	P_N		
	(mm)	(mm)	(mm)	(mm)		Stück each	(Nm)	(Nm)	(kN)	(N/ mm ²)	(N/ mm ²)		
CE13-15*	15	45	50	56	M 6 x 45	4	17	150	18	81		0,378	84,32
CE13-16*	16	45	50	56	M 6 x 45	4	17	160	18	76		0,370	84,32
CE13-18*	18	50	50	56	M 6 x 45	4	17	180	18	68		0,450	84,32
CE13-19*	19	50	50	56	M 6 x 45	4	17	190	18	64		0,444	84,32
CE13-20*	20	50	50	56	M 6 x 45	4	17	200	18	61		0,436	84,32
CE13-24*	24	55	60	66	M 6 x 55	6	17	360	27	63		0,632	87,04
CE13-25*	25	55	60	66	M 6 x 55	6	17	380	27	60		0,616	100,16
CE13-28*	28	60	60	66	M 6 x 55	6	17	370	24	46		0,752	106,40
CE13-30*	30	60	60	66	M 6 x 55	6	17	400	24	43		0,712	106,40
CE13-35*	35	75	75	83	M 8 x 70	4	41	640	32	41		1,328	140,16
CE13-40*	40	75	75	83	M 8 x 70	4	41	730	32	36		1,188	148,16
CE13-45*	45	85	85	93	M 8 x 80	6	41	1200	48	41		1,716	155,84
CE13-50*	50	90	85	93	M 8 x 80	6	41	1340	48	37		1,884	160,80
CE13-60*	60	100	85	93	M 8 x 80	8	41	2200	64	41		2,174	225,12
CE13-70*	70	115	100	110	M10 x 80	6	83	3200	80	38		4,000	352,64

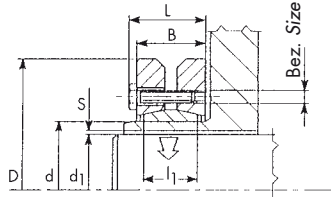

Type CE14

Bezeichnung Designation	Abmessung Dimension							Schrauben Screws			Bei Anzugsmoment M _s übertragbar With tightening torque M _s applied		Flächen- pression Pressure		Gewicht Weight	Fr./Stück each
	d	d ₁	D	B	L	l ₁	S	Bez. Design.	Anzahl No.	Anzugs- moment Tightening torque M _s	Drehmoment Torque	Axialkraft Axial force	Welle Shaft	Nabe Hub		
											M	F	P _W	P _N		
											(Nm)	(K _N)	(N/ mm ²)	(N/ mm ²)		
(mm)	(mm)	(mm)	(mm)	(mm)	(mm)	(mm)	Stück each	(Nm)	(Nm)	(K _N)	(N/ mm ²)	(N/ mm ²)	(kg)			
CE14- 24*	24	19	50	19	23,0	14	0,017	M5	6	4	180	26	140	280	0,184	137,92
		20									27	170	280			
		21									29	200	280			
CE14- 30*	30	24	60	21	25,0	16	0,017	M5	6	4	310	26	200	300	0,288	141,60
		25									27	205	300			
		26									28	220	300			
CE14- 36*	36	28	72	23	27,0	18	0,017	M6	6	12	460	50	235	360	0,468	153,12
		30									54	240	360			
		31									58	260	360			
CE14- 44*	44	32	80	25	29,0	20	0,032	M6	8	12	630	65	225	350	0,590	164,80
		35									74	240	350			
		36									77	255	350			
CE14- 50*	50	38	90	27	31,0	22	0,032	M6	8	12	940	79	180	285	0,794	175,68
		40									85	200	285			
		42									90	220	285			
CE14- 55*	55	42	100	30	34,0	23	0,032	M6	8	12	1200	80	155	250	1,104	191,36
		45									90	180	250			
		48									100	200	250			
CE14- 62*	62	48	110	30	34,0	23	0,032	M6	10	12	1800	100	190	270	1,312	205,60
		50									110	195	270			
		52									120	210	270			
CE14- 68*	68	50	115	30	34,0	23	0,038	M6	10	12	2000	100	140	250	1,304	216,16
		55									110	175	250			
		60									120	210	250			
CE14- 75*	75	55	138	33	38,0	25	0,048	M8	8	30	2500	120	190	300	1,700	223,36
		60									140	220	300			
		65									150	250	300			
CE14- 80*	80	60	145	32	38,0	25	0,048	M8	8	30	3200	120	185	280	2,540	255,20
		65									140	210	280			
		70									160	240	280			
CE14- 90*	90	65	155	39	45,0	30	0,048	M8	10	30	4700	170	180	260	3,300	386,40
		70									190	200	260			
		75									210	220	260			
CE14-100*	100	70	170	44	49,5	34	0,048	M8	12	30	6900	180	165	250	4,410	444,80
		75									220	185	250			
		80									240	190	250			
CE14-110*	110	75	185	50	57,0	39	0,048	M10	10	59	7200	230	160	260	5,900	675,36
		80									250	170	260			
		85									260	185	260			
CE14-115*	115	80	188	50	57,0	39	0,048	M10	10	59	8500	210	150	245	9,000	685,92
		85									240	170	245			
		90									270	180	245			
CE14-125*	125	85	215	54	61,0	42	0,056	M10	12	59	11000	300	160	260	8,600	692,96
		90									320	180	260			
		95									350	190	260			
CE14-130*	130	90	215	52	59,0	42	0,056	M10	12	59	13700	300	160	250	8,700	852,48
		95									330	180	250			
		100									360	190	250			

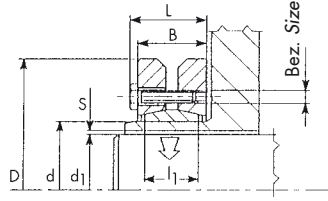

Type CE14

Bezeichnung Designation	Abmessung Dimension							Schrauben Screws			Bei Anzugsmoment M _s übertragbar With tightening torque M _s applied		Flächen- pressung Pressure		Gewicht Weight	Fr./Stück each
	d	d ₁	D	B	L	l ₁	S	Bez. Design.	Anzahl No.	Anzugs- moment Tightening torque M _s	Drehmoment Torque	Axialkraft Axial force	Welle Shaft	Nabe Hub		
											M	F	P _w	P _N		
											(Nm)	(kN)	(N/ mm ²)	(N/ mm ²)		
(mm)	(mm)	(mm)	(mm)	(mm)	(mm)	(mm)		Stück each	(Nm)	(kN)	(N/ mm ²)	(N/ mm ²)	(kg)			
CE14-140*	140	95	230	60	68,0	46	0,056	M12	10	100	15000	360	170	260	10,000	1.095,36
		100									400	185	260			
		20000									420	195	260			
CE14-155*	155	105	263	62	70,0	50	0,069	M12	12	100	20000	390	180	255	11,500	1.396,64
		110									420	190	255			
		26000									450	200	255			
CE14-165*	165	115	290	68	78,0	56	0,069	M16	8	250	36000	630	195	265	20,600	1.575,68
		120									660	200	265			
		44000									700	210	265			
CE14-175*	175	125	300	68	78,0	56	0,079	M16	8	250	40000	650	185	250	21,400	1.627,04
		130									680	190	250			
		49000									720	200	250			
CE14-185*	185	135	330	86	96,0	71	0,079	M16	10	250	55000	815	175	230	33,400	1.907,04
		140									60000	875	185	230		
		145									65000	896	190	230		
CE14-195*	195	140	350	86	96,0	71	0,079	M16	12	250	66000	950	210	265	38,000	2.954,56
		150									76000	1000	220	265		
		155									82000	1100	230	265		
CE14-220*	220	160	370	104	114,0	88	0,079	M16	15	250	95000	1200	190	235	54,000	3.564,32
		165									102000	1300	195	235		
		170									110000	1300	200	235		
CE14-240*	240	170	405	109	122,0	92	0,079	M20	12	490	120000	1500	210	260	67,000	4.664,96
		180									140000	1600	220	260		
		190									160000	1700	225	260		
CE14-260*	260	190	430	120	133,0	103	0,090	M20	14	490	165000	1700	205	250	82,000	5.489,12
		200									185000	1900	220	250		
		210									205000	2000	225	250		

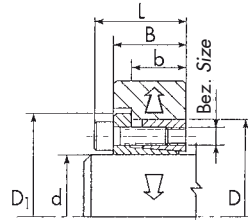

Type CE16

Bezeichnung Designation	Abmessung Dimension						Schrauben Screws			Bei Anzugsmoment M _s übertragbar With tightening torque M _s applied		Flächen- pression Pressure		Gewicht Weight	Fr./Stück each
										Drehmoment Torque	Axialkraft Axial force	Welle Shaft	Nabe Hub		
	d	D	D ₁	b	B	L	Bezeichnung Designation	Anzahl No.	Anzugs- moment Tighten- ing torque M _s	M	F	P _w	P _N		
	(mm)	(mm)	(mm)	(mm)	(mm)	(mm)		Stück each	(Nm)	(Nm)	(K _N)	(N/ mm ²)	(N/ mm ²)		
CE16-14x55*	14	55	62	23	31	39	M8 x 25	4	41	287	41	311	103	0,480	69,28
CE16-16x55*	16	55	62	23	31	39	M8 x 25	4	41	329	41	272	103	0,460	69,28
CE16-18x55*	18	55	62	23	31	39	M8 x 25	4	41	370	41	242	103	0,450	69,28
CE16-19x55*	19	55	62	23	31	39	M8 x 25	4	41	390	41	229	103	0,440	69,28
CE16-20x55*	20	55	62	23	31	39	M8 x 25	4	41	410	41	218	103	0,440	69,28
CE16-22x55*	22	55	62	23	31	39	M8 x 25	4	41	451	41	198	103	0,420	69,28
CE16-24x55*	24	55	62	23	31	39	M8 x 25	4	41	492	41	182	103	0,410	69,28
CE16-25x55*	25	55	62	23	31	39	M8 x 25	4	41	513	41	174	103	0,410	69,28
CE16-28x55*	28	55	62	23	31	39	M8 x 25	4	41	575	41	156	103	0,390	69,28
CE16-30x55*	30	55	62	23	31	39	M8 x 25	4	41	616	41	145	103	0,370	69,28
CE16-24x65*	24	65	72	23	31	39	M8 x 25	5	41	616	51	227	111	0,600	80,80
CE16-25x65*	25	65	72	23	31	39	M8 x 25	5	41	641	51	218	111	0,600	80,80
CE16-28x65*	28	65	72	23	31	39	M8 x 25	5	41	718	51	194	111	0,580	80,80
CE16-30x65*	30	65	72	23	31	39	M8 x 25	5	41	770	51	182	111	0,570	80,80
CE16-32x65*	32	65	72	23	31	39	M8 x 25	5	41	821	51	170	111	0,540	80,80
CE16-35x65*	35	65	72	23	31	39	M8 x 25	5	41	898	51	156	111	0,520	80,80
CE16-38x65*	38	65	72	23	31	39	M8 x 25	5	41	975	51	143	111	0,480	80,80
CE16-40x65*	40	65	72	23	31	39	M8 x 25	5	41	1026	51	136	111	0,460	80,80
CE16-30x80*	30	80	88	26	34	42	M8 x 25	7	41	1077	72	227	108	1,040	98,88
CE16-32x80*	32	80	88	26	34	42	M8 x 25	7	41	1150	72	213	108	1,000	98,88
CE16-35x80*	35	80	88	26	34	42	M8 x 25	7	41	1257	72	194	108	0,960	98,88
CE16-38x80*	38	80	88	26	34	42	M8 x 25	7	41	1364	72	179	108	0,930	98,88
CE16-40x80*	40	80	88	26	34	42	M8 x 25	7	41	1436	72	170	108	0,900	98,88
CE16-42x80*	42	80	88	26	34	42	M8 x 25	7	41	1509	72	162	108	0,900	98,88
CE16-45x80*	45	80	88	26	34	42	M8 x 25	7	41	1616	72	151	108	0,870	98,88
CE16-48x80*	48	80	88	26	34	42	M8 x 25	7	41	1723	72	142	108	0,850	98,88
CE16-50x80*	50	80	88	26	34	42	M8 x 25	7	41	1796	72	136	108	0,820	98,88

Nachdruck, auch auszugsweise, verboten. *Reproduction, in full or part is forbidden.*

Zu widerhandlungen werden urheberrechtlich verfolgt. *Any infringement will be prosecuted under the copyright act law.*

Irrtum sowie Änderungen durch technischen Fortschritt vorbehalten. *Subject to correction or change without notice due to technological progress.*

Bezüglich der Haftung und Lieferung verweisen wir auf unsere allgemeinen Geschäftsbedingungen.

Concerning liability and delivery refer to our general terms and conditions.

Die allgemeinen Verkaufsbedingungen sind in der jeweils gültigen Fassung auf der Internetseite unter www.optibelt.com einzusehen. Auf Wunsch können Ihnen diese zugesandt werden.
The latest version of the general conditions of sale can be viewed on the Internet under www.optibelt.com. We can send it to you on request.

© Arntz Optibelt Gruppe 471024/0111 Hux

optibelt



Lieferprogramm Product Range



1 5	optibelt RED POWER II optibelt KB RED POWER II Hochleistungs-Schmalkeilriemen, wartungsfrei <i>High Performance Wedge Belts, Maintenance-Free</i>	1	2	3	4	14	optibelt OMEGA HL optibelt OMEGA HP optibelt OMEGA FanPower optibelt OMEGA linear Zahnriemen aus Chloropren <i>Chloroprene Timing Belts</i>
2 6	optibelt BLUE POWER optibelt KB BLUE POWER Hochleistungs-Schmalkeilriemen <i>High Performance Wedge Belts</i>	5	6	7	8	15	optibelt ALPHA Power
3 7	optibelt SK optibelt KB SK Schmalkeilriemen <i>Wedge Belts</i>	9	10	11	12	16	optibelt ALPHA optibelt ALPHA linear / V optibelt ALPHAflex Zahnriemen aus Polyurethan <i>Polyurethane Timing Belts</i>
4 8	optibelt VB optibelt KB VB Klassische Keilriemen <i>Classical V-Belts</i>	13	14	15	16	17	optibelt DK Doppelkeilriemen <i>Double Section V-Belts</i>
9	optibelt Super X-POWER M-S Keilriemen, flankenoffen, formgezahnt <i>V-Belts, Raw Edge, Moulded Cogged</i>	17	18	19	20	18	optimat OE Endliche Keilriemen DIN 2216, gelocht <i>Open-Ended V-Belting, Punched</i>
10	optibelt Super KBX-POWER Kraftbänder, flankenoffen <i>Kraftbands, Raw Edge</i>	21	22	23	24	19	optibelt RB Rippenbänder <i>Ribbed Belts</i>
11	optibelt SUPER VX Breitkeilriemen, flankenoffen, formgezahnt <i>Variable Speed Belts, Raw Edge, Moulded Cogged</i>					20	optibelt RR / RR PLUS Kunststoffrundriemen <i>Plastic Round Section Belting</i>
12	optibelt SUPER DVX Doppel-Breitkeilriemen, flankenoffen, formgezahnt <i>Double Section Variable Speed Belts, Raw Edge, Moulded Cogged</i>					21	optibelt KK Kunststoffkeilriemen <i>Plastic V-Belting</i>
13	optibelt ZR optibelt ZR linear Zahnriemen aus Chloropren <i>Chloroprene Timing Belts</i>					22	optibelt KS Keilrillenscheiben <i>V-Grooved Pulleys</i>
						23	optibelt ZRS Zahnriemenscheiben <i>Timing Belt Pulleys</i>
						24	optibelt RBS Rippenbandscheiben <i>Ribbed Belt Pulleys</i>
							optibelt SERVICE KIT